

# UNIT-1 METAL CASTING PROCESS

---

## UNIT-I METAL CASTING PROCESS

### 1. Define foundry (AU MAY-JUNE 2006)

A plant where the castings are made is called foundry.

### 2. Define casting. (AU MAY-JUNE 2006, 2014)

It is the process of producing metal parts by pouring molten metal into the mould cavity of the required shape and allowing the metal to solidify. The solidified metal piece is called as casting.

### 3. Define mould.

Mould is the cavity of the required shape to be made in the molding sand or in other material.

### 4. Define pattern. (MAY/JUNE 2014)

The model of the required casting made in wood. Metal or plastics.

### 5. Name the various pattern materials. (AU MAY-JUNE 2006)

Wood – teak wood, mahogany, white pine, etc,

Metal – cast iron, brass, aluminum, etc

Plaster

Plastics

Wax

### 6. What are the difference between shaking allowance and other allowance? (AU MAY-JUNE 2006)

In shaking allowance, the extra size is subtracted from the pattern dimensions. In other allowance, the extra size is added with the pattern dimensions.

### 7. When do you make core or what is function of core in molding sand?

To provide a hollow surface or recess on the casting. The core is made.

## UNIT-1 METAL CASTING PROCESS

---

### 8. What do you understand by core setting?

Curing or heating the cores to obtain enough hardness is called as core setting.

### 9. What is a core point? Mention its purpose?

A core point is an extra projection on the pattern. It supports the core.

### 10. What are the requirements of core sand?

- Permeability
- Refractoriness
- Strength
- Collapsibility
- Stability

### 11. Name the different types of core binders.

- Oil binders
- Water soluble binders
- Resin binders
- Inorganic binders

### 12. State the various types of core boxes.

- Half box dumps or slap core box
- Split core box
- Stickle core box
- Gang core box

### 13. State any two core drying ovens.

- Batch type ovens
- Continuous type ovens
- Dielectric baking oven

### 14. What are the different types of patterns used in foundries.

- Solid or single piece pattern
- split pattern
- Loose piece pattern
- Match plate pattern
- Sweep pattern
- Skeleton pattern
- Segmental pattern
- Shell pattern

### 15. Define pattern allowances or what the main purpose of providing pattern is.

The amount of increase in size for compensating the reduction of dimensions due to

## UNIT-1 METAL CASTING PROCESS

---

shrinkage, machining, drafting, shaking and distortion, effect.

### **16. When do you make core or what is function of core in molding sand?**

To provide a hollow surface or recess on the casting. The core is made.

### **19. What are the core making materials or core sand ingredients?**

\*Core sand binders \*Additives \*Moisture

### **20. Where the balanced core is generally used?**

This type of core is used when the blind holes along a horizontal axis are to be produced.

### **21. What is the final product of CO<sub>2</sub> process?(AU MAY-JUNE 2007)**

Silica gel which binds the sand grains together in the final product of CO<sub>2</sub> process.

### **22. Mention the specific advantages of CO<sub>2</sub> process. (Nov/Dec-2018)**

Gives strength and hardness to core

Process cost is less

It saves time on heating

It can be stored for long use.

### **23. What is the properties good molding sand? (AU MAY-JUNE 2007)**

Porosity or permeability

Plasticity or flow ability

Strength or cohesiveness

Adhesiveness

Refractoriness

Collapsibility

### **24. What are the ingredients of molding sand?**

Binders

Additives

Moisture

### **25. State the purpose of adding ingredient to the molding sand.(AU NOV-DEC 2007)**

To increase the strength

To ensure collapsibility

To increase cohesiveness and adhesiveness

## UNIT-1 METAL CASTING PROCESS

---

### 26. What are the different types of molding sand?

Green sand  
Dry sand  
Synthetic sand  
Loam sand  
Special sand  
Parting sand

### 27. Write the composition of good molding sand?(Nov/Dec-2018)

#### Green sand:

It contains 5 to 8% water and 15 to 20% clay.

#### Loam sand:

Loam sand is a mixture of fine sands, fine refractories, clay, graphite powder and water. It contains more clay (50%)

### 28. What is meant by tempering of the sand?

The process of spraying and mixture adequate amount of water with the sand in the Muller is called a tempering

### 29. What are the various stages involved in sand conditioning?

Removing foreign materials  
Distributing the binder uniformly  
Controlling the moisture  
Aerating the sand and  
Delivering at proper temperature

### 30. List out any five molding tools. (AU NOV-DEC 2007)

Shovel  
Riddle  
Rammer  
Trowel  
Slick  
Strike – off – bar  
Lifter

### 31. What is the use of swab and vent – wire?

Swab: the swab is used to apply water in the sand around to pattern.



## UNIT-1 METAL CASTING PROCESS

---

Vent-wire

It is used to make small holes on the mould after ramming.

### 32. What are the uses of runner and riser?

Runner:

It is used to make a spree a hole in the cope.

It receives the molten metal from the pouring basin and passes to the cavity

Riser:

It supplies excuses molten metal to the solidifying casting.

It allows the escape of air.

### 33. What are chaplets?

Sometimes, it is not possible to provide sufficient support for a core in the mould being poured, if the cores are bigger in size. In such cases, the core is supported with rigid metal pieces called chaplets.

### 34. State the various methods for testing molding sand.

Moisture content test

Clay content test

Grain fitness test

Permeability test strength test deformation and toughness test hot strength test

Refractoriness test

Mould hardness test

### 35. Write down the formula for calculating the percentage of clay content.

Percentage clay content =  $w_1/w_2 * 100$

### 36. Define deformation. (AU MAY-JUNE 2010)

Deformation is defined as the plasticity of sand that can be tested by reducing the length of specimen applying compressive force on it.

### 37. State the different types of molding processes.

Green sand mould

Dry sand mould

Loam sand mould

## UNIT-1 METAL CASTING PROCESS

---

**38. Mention any two differentials between green sand mould and dry sand mould.**

<b>Green sand mould</b>	<b>Dry sand mould</b>
Less time for making mould	More time consuming
Less surface finish	Better surface finish
Low strength	Stronger than green sand mould
Less permeability	More permeability

**39. What are the different types of furnaces used for casting?**

Cupola furnace  
Open hearth furnace  
Crucible furnace  
Pot furnace  
Electric furnace

**40. List the factors to be considered in the choice of metal melting furnaces. .(AU MAY-JUNE 2010)**

Cupola furnace – for cast iron  
Open hearth furnace – for steel  
Crucible furnace – for non-ferrous metal  
Electric furnace – for steel, alloy steel, brasses.

**41. What are the types of Crucible furnace?**

Pit furnace  
Coke fired stationary furnace  
Oil fired tilting furnace

**42. State the principle of thermocouple pyrometer? (AU MAY-JUNE 2011)**

When the two junctions are held at different temperatures a voltage is generated in the circuit. This voltage is measured by a galvanometer which is calibrated in degrees of temperature instead of electrical unit.

**43. What does the different disappear in optical pyrometer?**

When the brightness of light of filament is equal to the rightness of light of molten metal, the filament disappears.

**44. What is die casting? (AU MAY-JUNE 2011)**

The mould used for making a casting is permanent, called a die – casting.

## UNIT-1 METAL CASTING PROCESS

---

**45. What are the types of alloys cast in cold chamber die casting machines? (AU NOV-DEC 2010)**

Household equipments like washing machine parts, vacuum cleaner body, fan case, stove parts, etc. Automobile parts like fuel pump, carburetor body, horn , wiper, and crank case. Components for telephones, television sets, speakers, microphones, record players and so on.

Toys like pistols, electric trains modal aircrafts etc.

**46. State any two limitations of full mould casting.**

Only small parts can be made

Dimensional accuracy is less.

**47. What are the reasons for the casting defects of cold shuts and misrun?(AU NOV-DEC 2010)**

Cold shuts - low pouring temperature and too small gate misrun - faulty molding and faulty molding box equipments.

**48. Give four reasons for the casting defects 'hot tear'**

Very hard ramming

To low pouring temperature

Small gates

Faulty design of pattern inclusion

**49. Name four different casing defects (Nov/Dec-2013)(Apl/May-2019)**

Shifts - two halves mismatching of casting

Hot fear - internal or external cracks

Fins - thin projection on parting line

Inclusions - foreign material present in casting.

**50. How casting defects are indentified?**

The casting defects are indentified by conducting various tested such as X-ray test. Magnetic particle test, liquid penetrate test and ultrasonic test.

**51. State any four types of pattern. (May/ June 2012)**

The following types of pattern are normally used

- Solid or single piece
- Split pattern
- Loose piece pattern

## UNIT-1 METAL CASTING PROCESS

---

- Match plate pattern.

**52. What are the causes for the formation of blow holes in the sand casting? (May/ June 2012)**

The causes for the formation of blow holes in the sand casting are

- Excess moisture
- Hard ramming
- Improper Venting
- Using more binder.

**53. What is meant by core print?[AU-NOV/DEC-2012](Nov/Dec-2018)**

A core print is an extra projection on the pattern. Core print forms a seat in the mould. The core print is supported in the seat formed by the core print.

**54. Name the different metal melting furnaces used in foundries . [AU-NOV/DEC-2012]**

1. Cupola furnace-For cast Iron
2. Open hearth furnace-For steel
3. Crucible furnace-For non-ferrous metal
  - a. Pit type furnace
  - b. Coke fired stationary furnace
  - c. Oil fired tilting furnace
4. Pot furnace
5. Electric furnace
  - a. Direct arc furnace
  - b. Indirect arc furnace
  - c. Induction furnace

**55. Compare the advantage of metal moulds over sand (expandable) moulds. (May/ June 2013)**

<b>Metal moulds</b>	<b>Sand moulds.</b>
It has accurate in size	It has slightly variation in size
It has smooth surface	It has rough surface

## UNIT-1 METAL CASTING PROCESS

---

### 56. What are the function of flux in melting metals and alloy? (May/ June 2013)

**Fluxes for melting** metals and alloy are solid substances (commonly mixtures of chloride and fluoride salts) used in metals and alloy [foundries](#) in order to reduce the melt oxidation, minimize penetration of the atmospheric [Hydrogen](#), absorb non-metallic inclusions suspended in the melt, keep the furnace/ladle wall clean from the built up oxides.

### 57. Differentiate shrinkage and porosity. (Nov/Dec-2013)

Sl.No	Shrinkage	Porosity
1.	The metal shrinks on solidification and contracts further on cooling to room temperature. To compensate this, the pattern is made larger than the required casting	Porosity is a measure of molding sand by which the sand allows the steam and gases to pass through it
2.	This extra size provided on the pattern for metal shrinkage is called shrinkage allowance.	To escape these gases, the molding sand should have good gas permeability or porosity.

### 58. Name the steps involved in making a casting.

Steps involved in making a casting are

- (1) Pattern making
- (2) Sand mixing and preparation
- (3) Core making
- (4) Melting
- (5) Pouring
- (6) Finishing
- (7) Testing
- (8) Heat treatment
- (9) Re-testing

### 59. What are the applications of casting?

Transportation vehicles (in automobile engine and tractors)

- Machine tool structures
- Turbine vanes and power generators
- Mill housing
- pump filter and valve

### 60. Define pattern.

A pattern is defined as a model or replica of the object to be cast.

A pattern exactly resembles the casting to be made except for the various allowances.

## UNIT-1 METAL CASTING PROCESS

---

### **61. Define mould making.**

It is a model or form around which sand is packed to give rise to a cavity called as **mould cavity**, in which molten metal is poured and the casting is produced.

### **62. Why is a pattern larger than casting?**

A pattern is slightly larger than the casting because a pattern carries allowance compensate for metal shrinkage.

### **63. What do you mean by core prints in pattern?**

To produce seats for the cores in the mould in which cores can be placed, for producing cavity in the casting. Such seats in the mould are called as core prints.

### **64. Name the functions of pattern.**

- (1) Prepare a mould cavity
- (2) To produce seats for the cores
- (3) To establish the parting line
- (4) To minimize casting defects.

### **65. Name the materials for making patterns**

The common materials of which the patterns are made are as follows:

- |             |           |             |
|-------------|-----------|-------------|
| (1) Wood    | (2) Metal | (3) Plastic |
| (4) Plaster | (5) Wax   |             |

### **66. List the various alloys and metal used in pattern.**

The various metals and alloys employed for making patterns are :

- |                              |               |
|------------------------------|---------------|
| (a) Aluminium and its alloys | (b) Steel     |
| (c) Brass                    | (d) Cast iron |
| (e) White metal              |               |

### **67. Explain wax molding.**

After being molded, the wax pattern is not taken out; rather the mould is inverted and heated and the molten wax comes out or gets evaporated, hence there is no chance of the mould cavity getting damaged while removing the pattern.

### **68. List the allowances of pattern.**

The following allowances are provided on the pattern

- (a) Shrinkage or contraction allowance
- (b) Machining allowance
- (c) Draft or taper allowance
- (d) Distortion allowance
- (e) Rapping or shake allowance

### **69. List the three forms of contraction.**

Contraction takes place in three forms

- (1) Liquid contraction
- (2) Solidifying contraction
- (3) Solid contraction

## UNIT-1 METAL CASTING PROCESS

---

### **70. Shrinkage of metal depends on what factors?(Apl/May-2019)**

The shrinkage of metal depends on the following factors

- (1) The metal to be cast
- (2) Pouring temperature of the molten metal
- (3) Dimensions of the casting
- (4) Method of molding

### **71. What do you mean by finish allowance?**

Machining allowance or finish allowance is the amount of dimension on a casting which is made oversized to provide stock for machining.

### **72. What are the factors on which amount of machining depends?**

Factors affecting machining are

- (1) Metal of casting
- (2) Machining method used
- (3) Casting method used
- (4) Shape and size of the casting
- (5) Amount of finish required on the machined portion

### **73. Why is a taper allowance used?**

Draft allowance or taper allowance is given to all vertical faces of a pattern for their easy. Removal of sand without damaging the mould.

### **74. When does war page occur?**

War page occurs when

- (1) It is of irregular shape.
- (2) It is of U or V-shape
- (3) The arms having unequal thickness.
- (4) One portion of the casting cools at a faster rate than the other.

### **75. How do you eliminate war page?**

To eliminate this defect, an opposite distortion is provided on the pattern, so that the effect is balanced and correct shape of the casting is produced

### **76. Enlist the factors affecting selection of types of pattern.**

The type of pattern to be used for a particular casting will depend on following factors :

- (1) Quantity of casting to be produced
- (2) Size and shape of the casting
- (3) Type of molding method
- (4) Design of casting

### **77. Name any four types of pattern.**

The various types of patterns which are commonly used are as follows :

- (1) Single piece or solid pattern
- (2) Two piece or split pattern
- (3) Loose piece pattern
- (4) Cope and drag pattern
- (5) Gated pattern

## UNIT-1 METAL CASTING PROCESS

---

### 78. Write the significance of loose molding.

Some patterns embedded in the molding sand cannot be withdrawn; hence such patterns are made with one or more loose pieces for their easy removal from the molding box.

### 79. Name and give use of the pattern in which number of casting are made at a time Gated pattern

by using gated patterns number of casting can be made at a time, hence they are used in mass production system.

### 80. Piston rings are made by .....pattern

Match plate pattern

These patterns are made in two pieces i.e. one piece mounted on one side and the other on the other side of the plate, called as match plate.

### 81. What is the difference between sweep and segmental pattern?

The main difference between them is that, a sweep is given a continuous revolving motion to generate the required shape, whereas a segmental pattern is a portion of the solid pattern itself and the mould is prepared in parts by it.

### 82. Why are patterns colored?

Patterns are provided with certain colors and shade for following reasons:

- (i) To identify quickly the main pattern body and different pattern parts.
- (ii) To indicate the type of the metal to be cast.
- (iii) To identify loose pieces, core prints, etc.
- (iv) To visualize machined surfaces, etc.

### 83. Selection of mould materials depends on.....

Selection depends on following factors

- (i) cost of the material
- (ii) Quality of casting required
- (iii) Number of casting required
- (iv) Shape and size of the casting
- (v) Material to be cast, etc.

### 84. What are the types of molding sand?

All types of sands used in the foundry can be grouped as:

1. Natural sand
2. Synthetic sand
3. Special sands

### 85. Why is synthetic sand better than natural sand?

- (1) It requires less proportion of binder.
- (2) Higher refractoriness and permeability.
- (3) Properties can be easily controlled.
- (4) Refractory grain size is more uniform.

### 86 Name the different types of special sand.

Types of special sand are

- (1) Green sand
- (2) Loam sand
- (3) Core sand
- (4) Parting sand
- (5) Facing sand
- (6) Backing sand



## UNIT-1 METAL CASTING PROCESS

---

### 87 Define black sand

It is the sand which backs up the facing sand and does not come in direct contact with the pattern. This sand has black color and hence, sometimes called as black sand.

### 88. Define green strength.

A mould which has adequate green strength will retain its shape and does not distort or collapse, even after the pattern has been removed from the molding box.

### 89. Define permeability.

The sand must be porous to allow the gases and steam generated within the moulds to be removed freely. This property of sand is known as permeability or porosity.

### 90 Name the constituents of molding sand.

The main constituents of molding sand are :

- |               |            |
|---------------|------------|
| (1) Sand      | (2) Binder |
| (3) Additives | (4) Water  |

### 91. Classify binders and name the types in it

- |                      |                     |
|----------------------|---------------------|
| 1) Organic binders   |                     |
| (a) Linseed oil      | (c) Dextrin         |
| (b) Molasses         | (d) Pitch           |
| 2) Inorganic binders |                     |
| (a) Clay,            | (b) Sodium silicate |
| (c) Portland cement  |                     |

### 92. Name the types of clay binders

Clay binder which is most widely used have following types:

- |               |               |              |
|---------------|---------------|--------------|
| (a) Bentonite | (b) Fire clay | (c) Limonite |
| (d) Ball clay | (e) Kaolinite |              |

### 93. Additives are used so as to.....

- 1) To enhance the existing properties.
- 2) To develop certain other properties like resistance to sand expansion defects, etc.

### 94 What do you mean by coal dust?

It reacts chemically with the oxygen present in the sand pores and thus, produces a reducing atmosphere at the mould metal interface and prevents oxidation of the metal.

### 95. Functions of sand preparation are.....

- (1) To develop optimum properties in the molding sand.
- (2) To obtain even distribution of sand grains throughout the bond.
- (3) To add suitable amount of water to activate clay binder.
- (4) To deliver sand at the suitable temperature.

### 96. Define Muller.

It is a mechanical mixer used for mixing sand ingredients in dry state.

## UNIT-1 METAL CASTING PROCESS

---

**97. Name various methods of sand testing.**

- |                           |                         |
|---------------------------|-------------------------|
| (1) Moisture content test | (2) Clay content test   |
| (3) Permeability test     | (4) Grain fineness test |

**98. Name the factors affecting permeability test.**

Permeability depends on the following factors:

- Grain shape and size
- Grain distribution
- Binder and its contents
- Water amount in the molding sand
- Degree of ramming

**99 Enlist the functions of core.**

Core provides a means of forming the main internal cavity for hollow casting.

Core provides external undercut feature.

Cores can be inserted to obtain deep recesses in the casting. Cores can be used to increase the strength of the mould.

**100 Define Core.**

Core is a sand shape or form which makes the contour of a casting for which no provision has been made in the pattern for molding.

**101. Difference between core sand and mould sand.**

The main difference is that core sand has very low clay content and larger grain size.

**102. Core sand mixture consists of...**

Core sand mixture consists of sand, 1% core oil, 1% cereal and 2.5 to 6% of water.

**103 Name the core sand ingredients.**

**Ingredients are**

- |                             |                  |
|-----------------------------|------------------|
| (1) Granular refractoriness | (2) Core binders |
| (3) Water                   | (4) Additives    |

**104 What does core making consists of ?**

Core making basically consists of following steps:

- |                           |                                |
|---------------------------|--------------------------------|
| (1) Core sand preparation | (2) Core making                |
| (3) Core baking           | (4) Core finishing or dressing |
| (5) Setting the cores     |                                |

**105. Define core driers.**

The special shapes, which support the green sand cores having curved surfaces, are known as core driers.

**106 List various types of core.**

Their main types are as follows

- |                     |                   |                  |
|---------------------|-------------------|------------------|
| (1) Horizontal core | (2) Vertical core | (3) Hanging core |
|---------------------|-------------------|------------------|
-

## UNIT-1 METAL CASTING PROCESS

---

- (4) Balanced core                      (5) Ram up core                      (6) Kiss core  
(7) Drop core

### 107. What is core box?

Core box is a pattern for making cores. They are employed for ramming cores in them. Core boxes provide the required shape to the core sand.

### 108. Name the types of core boxes.

- (1) Half core box                      (2) Dump core box  
(3) Split core box                      (4) Stickle core box  
(5) Gang core box                      (6) Loose piece core box  
(7) Left and right hand core boxes

### 109. Why do we use a core prints?

Core prints are basically extra projections provided on the pattern. They form core seats in the mould when pattern is embedded in the sand for mould making. Core seats are provided to support all the types of cores.

### 110. Name the types of core prints.

: Core prints are of the following types:

- (i) Horizontal core print                      (ii) Vertical core print  
(iii) Balanced core print                      (iv) Cover core print

### 111. Define mould.

When the pattern is removed, a cavity corresponding to the shape of the pattern remains in the sand which is known as mould or mould cavity

### 112. What is loam molding?

In this, a rough structure of component is made by hand using bricks and loam sand. The sand used is known as loam sand or loam mortar.

### 113. Explain in short shell molding.

Shell molding is suitable for thin walled articles.

It consists of making a mould that has two or more thin shell like parts consisting of thermosetting resin bonded sand.

### 114. Name any six hand mould tools

A number of hand tools are

- (1) Shovel                      (2) Hand riddle                      (3) Rammers  
(4) Lifters or cleaners                      (5) Draw spike                      (6) Bellow

### 115. Functions of molding machine.

The main functions of molding machines are:

Ramming of molding sand.

Rolling over or inverting the mould through 180°

Rapping of pattern.

Removing the pattern from the mould.

## UNIT-1 METAL CASTING PROCESS

---

**116 Name the types of molding machine.**

Following are the types of molding machines:

- (a) Squeeze molding machines
- (b) Jolt molding machines
- (c) Jolt-squeezing machines
- (d) Sand slinger

**117 Difference between permanent mould casting and sand casting.**

The main difference between permanent mould casting and sand casting is that, in this the mould is permanent which is neither destroyed nor remade after each cast.

**118. Name the type of die casting machine.**

The main types of die-casting machines are:

- (a) Hot chamber die-casting
- (b) Cold chamber die-casting

**119 Classify centrifugal casting**

Centrifugal casting processes can be classified as:

- (a) True centrifugal casting
- (b) Semi-centrifugal casting
- (c) Centrifuging

**120. What do you mean by shaking out operation ?**

After solidification of casting, the mould are broken to obtain the final casting. This operation is known as shake out operation, which may be performed manually or mechanically.

**121. Operations performed after shaking are.....**

The various operations which are performed after shake out are as follows :

- (a) Removal of dry sand cores.
- (b) Removal of gates, risers, runners, etc.
- (c) Removal of unwanted metal projections, fins, etc.
- (d) Removal of adhering sand and oxide, scale from the casting surface.

**122. Define snagging.**

The operation of removal of unwanted metal projections and fins is called as **snagging**.

**123. Name defects occurring in casting.**

- (1) Blow holes
- (2) Porosity
- (3) Shrinkage
- (4) Inclusions
- (5) Hot tears or hot cracks
- (6) Misrun and cold shuts

**124. Name the inspection methods of casting.**

- (1) Pressure test
- (2) Magnetic particle test
- (3) Dye penetrant test
- (4) Radiographic inspection
- (5) Ultrasonic inspection
- (6) Visual inspection

**125 What is the difference between magnetic and dye penetrate testing ?**

Magnetic testing is used for magnetic materials and dyes are used for non-magnetic materials.

## Unit – I

### Metal casting processes

**Sand Casting : Sand Mould – Type of patterns - Pattern Materials – Pattern allowances –Molding sand Properties and testing – Cores –Types and applications – Molding machines– Types and applications; Melting furnaces : Blast and Cupola Furnaces; Principle of special casting processes : Shell - investment – Ceramic mould – Pressure die casting - Centrifugal Casting - CO2 process – Stir casting; Defects in Sand casting**

### Metal Casting Process

#### Manufacturing

Manufacturing in its broadest sense is the process of converting raw materials into useful products.

It includes

- i) Design of the product
- ii) Selection of raw materials and
- iii) The sequence of processes through which the product will be manufactured.

#### Casting

Casting is the process of producing metal parts by pouring molten metal into the mould cavity of the required shape and allowing the metal to solidify. The solidified metal piece is called as “casting”.

#### Advantages

- ✓ Design flexibility
- ✓ Reduced costs
- ✓ Dimensional accuracy
- ✓ Versatility in production

#### Disadvantages

- ✓ Lot of molten metal is wasted in riser & gating
- ✓ Casting may require machining to remove rough surfaces

#### Sand Casting

Sand Casting is simply melting the metal and pouring it into a preformed cavity, called mold, allowing (the metal to solidify and then breaking up the mold to

remove casting. In sand casting expandable molds are used. So for each casting operation you have to form a new mold.

- ✓ Most widely used casting process.
- ✓ Parts ranging in size from small to very large
- ✓ Production quantities from one to millions
- ✓ Sand mold is used.
- ✓ Patterns and Cores

Solid, Split, Match-plate and Cope-and-drag Patterns

Cores – achieve the internal surface of the part

### **Molds**

- ✓ Sand with a mixture of water and bonding clay
- ✓ Typical mix: 90% sand, 3% water, and 7% clay
- ✓ To enhance strength and/or permeability and – Refractory for high temperature

### **Size and shape of sand**

- ✓ Small grain size -> better surface finish
- ✓ Large grain size -> to allow escape of gases during pouring
- ✓ Irregular grain shapes -> strengthen molds due to interlocking but to reduce permeability

### **Types of sand**

- a) Green-sand molds - mixture of sand, clay, and water; “Green” means mold contains moisture at time of pouring.
- b) Dry-sand mold - organic binders rather than clay and mold is baked to improve strength
- c) Skin-dried mold - drying mold cavity surface of a green-sand  
Mold to a depth of 10 to 25 mm, using torches or heating

### **Steps in Sand Casting**

The cavity in the sand mold is formed by packing sand around a pattern, separating the mold into two halves

The mold must also contain gating and riser system For internal cavity, a core must be included in mold A new sand mold must be made for each part

1. Pour molten metal into sand mold
2. Allow metal to solidify
3. Break up the mold to remove casting
4. Clean and inspect casting

5. Heat treatment of casting is sometimes required to improve metallurgical properties

**2. Describe briefly about the various types of molding tools used with sketch.**

(AU MAY – JUNE 2010)

**Molding tools:**

The following tools are used in a hand molding process.

- |                  |                 |
|------------------|-----------------|
| # Shovel         | # sprue pin     |
| # Riddle         | # riser pin     |
| # Rammer         | # gate cutter   |
| # Trowel         | # draw spike    |
| # Slick          | # swal          |
| # Strike-off-bar | # bellows       |
| # Lifter         | # mallet        |
| # Vent wire      | # molding boxes |

**1. Shovel**

- It is a steel pan with long wooden handle.
- It is used to mix and temper the molding sand with clay, moisture and other additives before pouring into the mould.

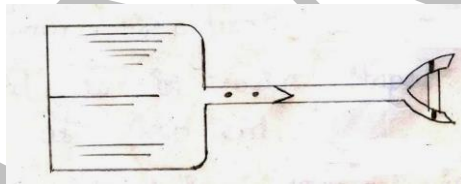


Fig: Shovel

- It is also used for carrying the molding sand from the sand pit or pill to the molding box.
- Now a day, a cast iron handle is also used.

**2. Riddle:**

- Steel wire mesh (screen) fitted into a circular or square frame is called riddle.
- It is used for removing foreign materials such as stones, nails, etc.
- It is also used to separate various sizes of sand grains.

**3. Rammer:**

- It is used to ram or pack the sand in the box.
- It is normally made of wood or metal.

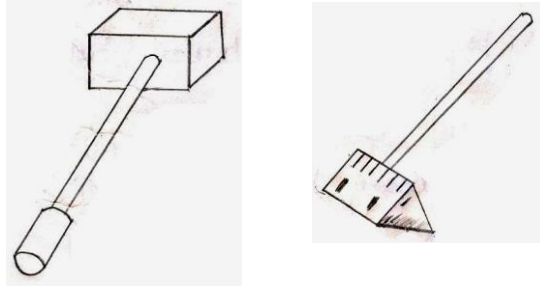


Fig: Rammer

- Rammer has two ends. Such that
- One end is in wedge shaped and is known as peen end.
- The other end is cylindrical in shaped is known as butt end.

**4. Trowel:**

- It has a metal pan with a short wooden handle.
- The pan may be in different shapes.

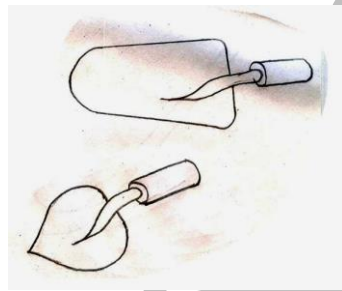


Fig: Trowel

- It is used to smoothen the surfaces of mould and repair the damaged portions of mould.

**5. Slick:**

- It is a spoon shaped doubled-ended trowel.

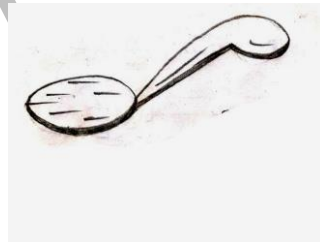


Fig: Double – ender or slick

- It is used for repairing and finishing small curved or straight surfaces and round corners of the mould.

**6. Strike-off-bar:**

- It is made of wood or metal



- It has a straight edge
- It is used to remove excess sand from the mould after ramming.

### 7. Lifter

- It is a bend and twisted blade as shown in figure.



Fig: Lifter

- It is used to lift dirt or loose sand from the deep mould.
- It is also used for repairing and finishing the cavity and gates.

### 8. Vent wire:

- It is a thin steel wire with handle.
- It is used to make small holes in the mould after ramming.

### 9. Sprue pin:

- It is a tapered cylindrical wooden piece.
- It is used to make a sprue hole in the cope.
- The sizes of sprue pin depend upon the size of the mould.
- The molten metal passes through this sprue hole to the cavity.

### 10. Riser pin.

- It is also a tapered wooden rod.



Fig: Riser pin

- Its size is smaller than the sprue pin. It is used to make a riser in the cope.

### 11. Gate cutter:

- It is a bend type of metal which is used to cut gates.

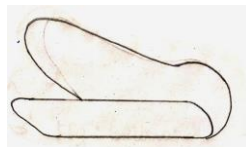


Fig: Gate cutter

- The gate is a passage between mould cavity and runner.

**12. Draw spike:**

- It is a pointed or threaded steel rod with a ring at one end as shown in fig.



Fig: Draw spike

- It is used to remove the pattern from the mould.

**13. Swab:**

- It is a small brush
- It is used to apply water on the sand around the pattern



Fig: Swab

- It may be used for sweep away the dust from the pattern or excessive sand from the mould joint or to give coating on the pattern.

**14. Bellows:**

- It is used to blow off loose sand particles from the mould and pattern.



Fig: Bellows

**15. Mallet:**

- It is wooden hammer which is used to drive the draw spike into the pattern and then lifts from the mould.

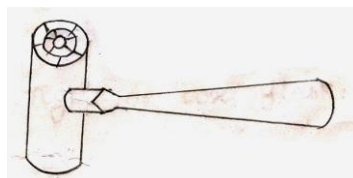


Fig: Mallet

### 16. Molding boxes:

- Molding box or flask is a frame or box of wood or metal which is used to hold molding sand.
- A molding box may be in two or three parts.
- The top part is cope
- The middle part is check
- The lower part is drag.

The main types of boxes are

- Snap flask
- Tight or box flask

#### (a) Snap flask

- It is generally made of wood.
- It has hinges on one corner opposite corners have latches to lock the flask in position.
- First the flask is locked to make mould. After making the mould, the latches are unlocked and flask is opened out.
- The flask is removed from the mould, number of moulds can be made with the help of one box in this way.

#### (b) Tight or box flask:

- It is a box shaped container without top or bottom.
- It is made of metal or wood.
- It is used for making small and medium size moulds.
- The top part (cope) and bottom part (drag) are held in position by dowel pins or bolt and nut.

### 3. Describe briefly the various pattern material used for making pattern.

**Pattern materials: (AU MAY – JUNE 2010)**

The following factors to be considered for selecting pattern materials

- ✓ Design of casting
- ✓ Number of casting to be produced

- ✓ Degree of accuracy and surface
- ✓ Finish required
- ✓ Shape, complexity and size of the castings
- ✓ Castings or molding method adopted patterns are made by different materials which have their own advantages, limitations and their field of applications.

Commonly used pattern making materials are given below.

- ✓ Wood-teak wood, mahogany, white pine, etc.
- ✓ Metal-cast iron, brass, aluminum, white metal etc,
- ✓ Plaster
- ✓ Plastics
- ✓ Wax

#### **Wood:**

- ✓ Wood is a material commonly used for pattern making.
- ✓ Generally, teak wood, mahogany, white pine, rose wood are used for making pattern.
- ✓ Laminated wooden sheets are also used for getting accuracy, surface finish and long life.
- ✓ These woods should not contain more than 10% moisture to avoid warping and distortion during subsequent drying.
- ✓ Metal spray coating up to 0.25mm thick may be given on wooden pattern.
- ✓ Zinc and aluminum are used for coating the metals and the wooden surface to avoid moisture absorption and good surface finish.

#### **Advantages:**

- ✓ It is light in weight, cheap and easily available.
- ✓ It is easy to work, easy to cut and easy to fabricate.
- ✓ It can be easily repaired
- ✓ It can be easily smoothed by varnishes and paints.

#### **Limitations:**

- ✓ It absorbs water from sand and changes its shape.
- ✓ It has non uniform structure.
- ✓ It has high wear and tear by sand. Hence, it cannot be used for mass production.
- ✓ It cannot be used in machine molding.

#### **Metal:**

- ✓ Metal pattern is used when a larger number of castings are to be made.

- ✓ Metal pattern can be either cast from a masterpiece or may be machined by the usual method of machining.
- ✓ These patterns are usually used in machine molding.

**Advantages:**

- ✓ It has long life and accurate in size.
- ✓ It has smooth surface mass production is possible.
- ✓ It does not absorb moisture and deform in size.
- ✓ It can be used for rough handling and its resistance to wear, tear abrasion and corrosion.

**Disadvantages:**

- ✓ It is costlier and heavier than wood.
- ✓ It cannot be easily repaired.
- ✓ Ferrous patterns can get rusted.
- ✓ It is difficult to make the required shape.

The materials commonly used for pattern making are,

- ✓ Cast-iron
- ✓ Brass
- ✓ Aluminium

**Cast-iron**

- ✓ Cast iron having fine grain can be used as a pattern material.
- ✓ It has high resistance to sand abrasion and smooth surface, but it is heavier and difficult to work.
- ✓ It cast is less and more durable than other metals.
- ✓ It is brittle and can be easily broken.
- ✓ It will get rusted by moisture unless it is protected.

**Brass:**

- ✓ It may be easily worked and built up by soldering or brazing.
- ✓ It is used only for small size pattern because of high cost.
- ✓ It is very strong and not affected by moisture.
- ✓ It takes very good surface finish and with sands wear and tear.
- ✓ It can make very high accuracy.

**Aluminium:**

- ✓ Aluminium is the best material because it is light in weight, strong and easily machined.
- ✓ It can be made with high accuracy and good surface finish. It will not be affected by moisture and get rusted and also melt low temperature.
- ✓ It is a very soft and easily damage by rough surfaces.

**4.Plastics:**

- ✓ A plastics pattern has many advantages over other materials.
- ✓ Plastics pattern is cast from a wooden pattern called master pattern.
- ✓ It is light in weight but strong.
- ✓ It is not affected by moisture and more resistance to wear.
- ✓ It has very smooth glassy surface.
- ✓ It does not shrink much and has high dimensional accuracy and more economical than other metals.

The following plastics are widely used for pattern making with the composition based on epoxy, phenol formaldehyde and polyester resins.

- ✓ Poly acrylates
- ✓ Poly ethylene
- ✓ Poly vinyl chloride etc.

**5. Wax:**

- ✓ Wax pattern is primarily used in investment castings.
- ✓ The commonly used waxes are paraffin wax, shellac wax and microcrystalline wax .
- ✓ It has good surface finish and high dimensional accuracy.
- ✓ It will not absorb moisture and easy to work.
- ✓ Cost is very less, but it can be used for making small patterns only.

**4. Explain the types of pattern in details. (AU NOV-DEC 2010)****Pattern:**

A pattern is one of the important tools used for making cavities in the mould into which molten metal is poured to produce a casting.

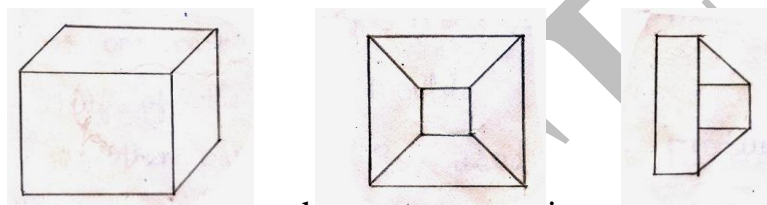
Types of patterns:

1. Solid or single piece pattern

2. Split pattern
3. Loose piece pattern
4. Match plate pattern
5. Sweep pattern
6. Skeleton pattern
7. Segmental pattern
8. Shall pattern

### 1. Solid or single piece pattern:

- ❖ These types of pattern are made of single solid piece without joints, partings or loose piece, it is called solid or one-piece pattern.



- ❖ It is to the ing to ced with some allowances.
- ❖ It is used for making a few large size simple castings.
- ❖ Removal of pattern from the sand is easy.

### 2. Split pattern:

- ❖ One pattern which is having complex geometry cannot be removed from mould if they are made by single piece.
- ❖ Generally split pattern is made into two parts.
- ❖ One part is used to produce the lower half of the mould.
- ❖ Other part is used to produce the upper half of the mould.
- ❖ These two parts are assembled together in correct position by pins called dowel pins.
- ❖ The line separating the two parts is called parting line.

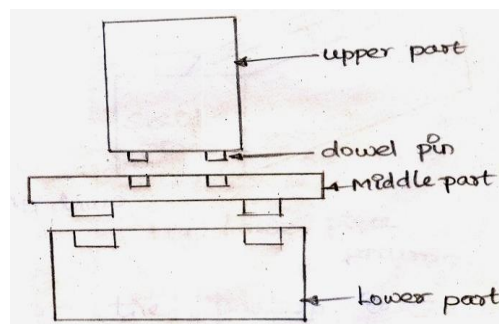
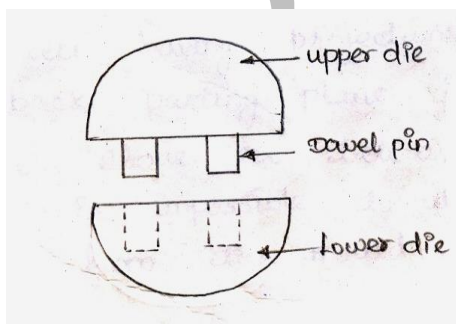




Fig: Split pattern

Fig: Three piece pattern

- ❖ If the split pattern are made of three pieces. Then it is called three piece patterns.

### 3. Loose piece pattern:

- ❖ If a pattern is made from a single piece having projections or back parting plane is lie above or below, it is impossible to with draw it from the mould.
- ❖ In such cases, the pattern is built up into solid pattern and loose pieces.

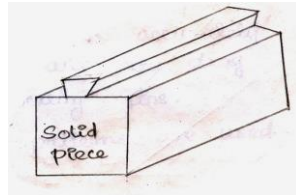


Fig: Loose piece pattern

- ❖ After making the mould, first the solid pattern is removed and then the loose pieces are removed without breaking mould. Is called loose piece pattern.
- ❖ Loose pieces are attached to the main body of the pattern by pins.

### 4. Match plate pattern:

- ❖ This pattern is made in two halves mounted on both sides of a plate called match plate which is made by aluminum or wood.
- ❖ The match plate is accurately placed between the cope and the drag flasks by means of locating pins.

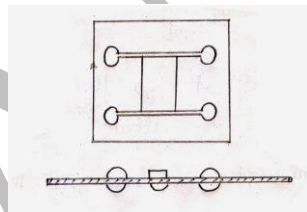


Fig: Match plate pattern

- ❖ Match plate patterns are used in machine molding.
- ❖ This type of pattern is used for small, accurate size and large number of castings.
- ❖ Piston rings of I.C engine are produced by this process.

### 5. Sweep pattern:

- ❖ Sweep patterns are mainly used to generate surfaces of revolution like cylinder, cone, sphere in large castings.



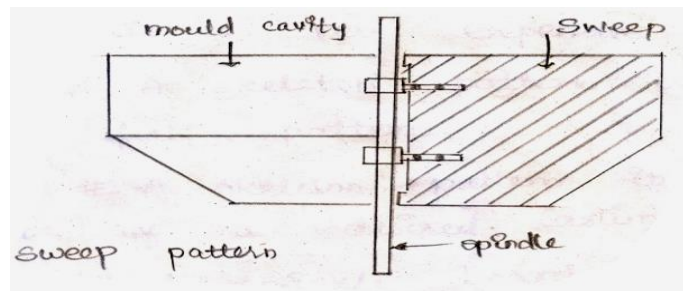
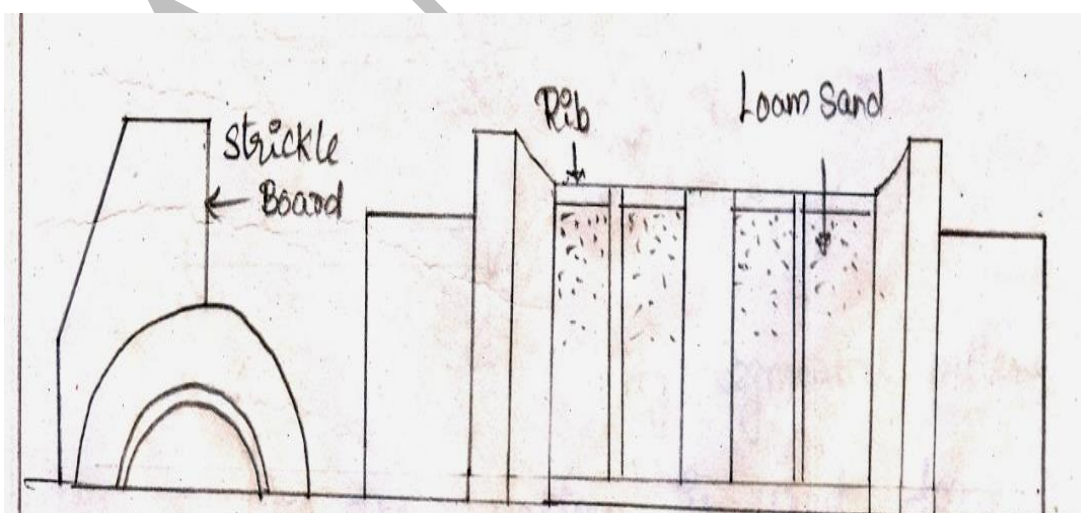


Fig: Sweep pattern

- ❖ A half of the board is fitted in the centre spindle.
- ❖ The sand is approximately rammed around the mould cavity.
- ❖ The sweep is rotated to form the mould cavity in the sand.
- ❖ Sweep patterns are used for making large and circular castings in loam molding.

#### 6. Skeleton pattern:

- ❖ For larger casting of simple shape. If a solid pattern is made of wood.
- ❖ It is very expensive.
- ❖ A skeleton pattern is used instead of a full pattern.
- ❖ A skeleton pattern is a ribbed frame of a desired casting.



- ❖ Molds for water pipes, turbine casings, pipe bends are made by skeleton pattern.

#### 7. Segmental pattern:

- ❖ A segmental pattern is a segment of whole pattern as shown in fig .

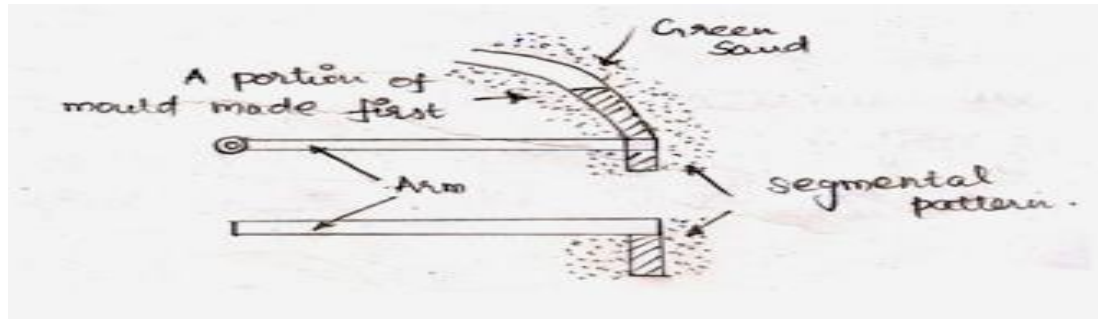


Fig: Segmental pattern

- ❖ This pattern is also called part pattern
- ❖ The pattern is used for forming circular moulds.
- ❖ This pattern is used for casting circular components such as rings, wheel rims, gear blanks, etc.

### 8. Shell pattern:

- ❖ Shell pattern is a hollow pattern its outer shape is used for making the mould.
- ❖ The core is prepared using the inner surface of the pattern itself. It is also known as block pattern.

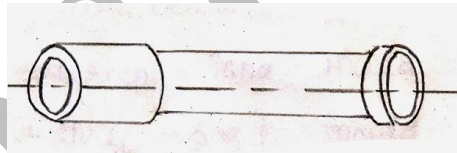


Fig: Shell pattern

- ❖ These patterns are usually made of metal.
- ❖ These patterns are mainly used for making drainage fittings and pipe work like short bends.

### 5. What are the types of molding process? And briefly explain.

#### Molding processes (AU NOV-DEC 2010)

Define the process of making a cavity similar to the product required in sand is called molding.

**There are different types of moulds given below.**

- Green sand mould
- Dry sand mould
- Loam mould

#### 1. Green sand mould:

- Green sand mould contains 10 to 15% clay, 4 to 6% of water and remaining

- percentage of silica sand.
- It is porous.
- It is that mould in which the molten metal is poured immediately after the mould is prepared.
- These moulds are preferred for making small and medium size castings.
- It is specially used for non-ferrous metals and alloy castings.

**Advantages:**

- The process is less expensive
- It can be used for all metals
- Mould distortion is less
- It does not restrict the free contraction of metal.
- It needs lesser time for making mould since drying is not required.

**Limitations:**

- Surface finish is less
- Strength of the mould is low
- Defects like blow holes may occur.

**2. Dry sand mould:**

- If the green sand mould is dried after making the mould, it is called dry sand mould.
- It is a mixture of silica sand, coal dust, and binders like clay, betonies and molasses etc.
- The step-by – step procedure of making dry sand mould is the same as that of green sand molding.

**Advantages:**

- It is stronger than green sand mould.
- It has better dimensional accuracy
- Permeability is more
- It can be stored for long time.

**Limitations:**

- It is a more time consuming process, since, it requires heating.
- Cost is high.
- It is subjected to hot tear.

**3. Loam molding:**

- Loam sand is a mixture of silica sand, water, graphite powder and more amount of clay.
- The mould made by using loam sand is called loam molding.
- This is made by using pit molding method.
- Initially, rough frame work is made by bricks. The loam sand is applied over the brick work.
- Loam molding is made also by skeleton pattern.

**Applications:**

- It is used for large cylinders large bells, wheels, kettles, gear wheels, pans and other large machine parts.

**Advantages:**

- Large castings can be made with less cost . since no pattern & mould boxed are required.
- It has good surface finish.
- Accurate casting can be produced.

**Limitations:**

- It is a time consuming process.
- Skilled labour are required.
- 

**6. Describe about the good properties needed for molding sand.**

A good casting can be produced only with the use of good quality molding sand.

**These properties are**

1. Porosity or permeability
2. Plasticity or flow ability
3. Adhesiveness
4. Strength or cohesiveness
5. Refractoriness
6. Collapsibility

**Porosity or permeability:**

Permeability is a measure of molding sand by which the sand allows the steam and gases to pass through it.

**Permeability of molding sand depends on the following factors.**

1. Quality and quantity of clays and quartz.
2. Moisture content

### 3. Degree of compactness.

#### **The following parameters which affect the permeability of molding sand.**

1. If the clay content is less the permeability will be more and vice-versa.
2. If the grain size is larger, the permeability will be more and vice versa.
3. Soft ramming (ie, less density) improves the permeability.
4. Higher the silica content on sand lower will be the permeability.

#### **2. Plasticity or flow ability:**

1. The property of molding sand by which the molding sand flows around and over the pattern, and uniformly fills the flask.
2. It gives the shape of the pattern and retains the shape after removing the pattern.
3. This property may be improved by adding clay and water to silica sand.

#### **3. Adhesiveness:**

1. The property of molding sand by which it sticks or adheres to another body.
2. The molding sand should cling or stick to the sides of the molding boxes.
3. It does not fall out when the flasks are lifted and turned over. This property depends on the type and amount of binder used in the sand mix.
4. Addition of clay and moisture increases the adhesiveness.

#### **4. Strength or cohesiveness:**

1. It is property of molding sand by which it sticks together.
2. A molding sand should have sufficient strength so that the mould does not collapse or get partially damaged during shifting, turning or pouring the molten metal.

#### **Strength of the molding sand depends on**

1. Grain size and shape
2. Moisture content
3. Density of sand after ramming strength is increased with increasing density, clay content and decreased size of sand grains.

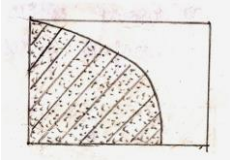
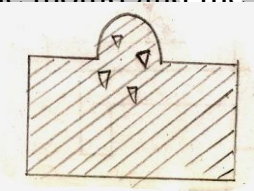
#### **5. Refractoriness:**

1. The property of molding sand to resist high temperature of molten metal.
2. This property mainly depends on the purity of the sand particles and size.
3. Rough and larger grain, and quartz content in molding sand increase the refractoriness.
4. Poor refractoriness will result in rough surface in casting.

**6. Collapsibility:**

1. The property of the molding sand to decrease in volume to some extent under the compressive forces developed by the shrinkage of metal during freezing and subsequent cooling.
2. This property permits the molding sand to collapse easily after the casting solidifies.
3. If the mould or core does not collapse, it may restrict the free contraction of the solidifying material and causes crack on the casting.
4. This property depends on the amount of quartz and binders.

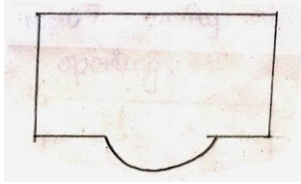
**7. Enumerate the various casting defects and suggest suitable remedies.(AU MAY-JUNE 2011, Nov/Dec-2012, 2013, May/June 2014) .**

Defects	Remedies
<p><b>1. Shrinkage:</b> It is a depression on the casting surface formed if these gases could not come out; blow holes are formed on the interior of the casting.</p> 	<ul style="list-style-type: none"> <li>• Proper solidification</li> <li>• Pour at correct temperature</li> <li>• Modify gating runner and riser system</li> <li>• Control moisture content</li> <li>• Ram property</li> <li>• Provides sufficient vent holes</li> <li>• Control bitter content</li> </ul>
<p><b>3. Scab:</b> It is the erosion or breaking down a portion of the mould and the recess filled with n</p> 	<ul style="list-style-type: none"> <li>• Provide uniform ramming.</li> <li>• Pour with correct velocity.</li> <li>• Ram property</li> </ul>

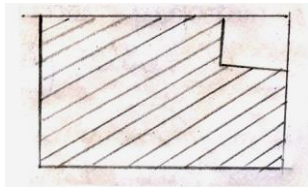


**4. Swell:**

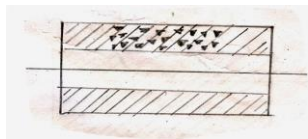
It is the enlargement of casting.

**5. Hard spots:**

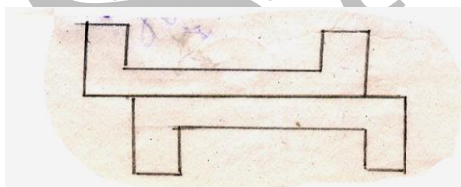
Some spots on the surface become hard.

**6. Honey combing:**

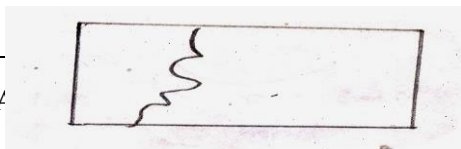
Number of small cavities present on the casting surface.

**7. Shift:**

Mismatching of casting sections.

**8. Cold shut:**

It is the incomplete filling of the mould casting at one opening.



- Pour with correct velocity
- Provide adequate support to the mould.

- Provide uniform coding
- Pour – at correct temperature

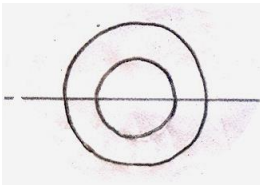
- Provide correct ramming
- Provide correct gating system.
- Pour at correct temperature.

- Repair or replace the pins and dowel pins in the pattern.
- Assemble the molding boxes properly.
- Provide proper box locating of core.

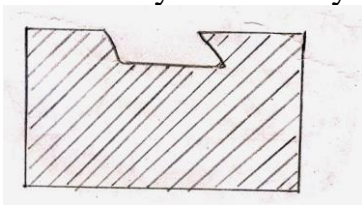
- Pour at correct temperature
- Provide correct gating system.

**9. Fins:**

This projection on parting line.

**10. Blister:**

The scar covered by the thin layer of a metal.

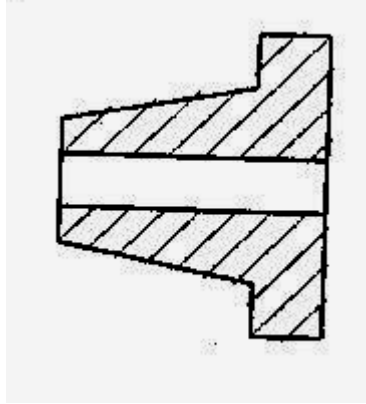


- Pour at correct temperature
- Modify gating system.

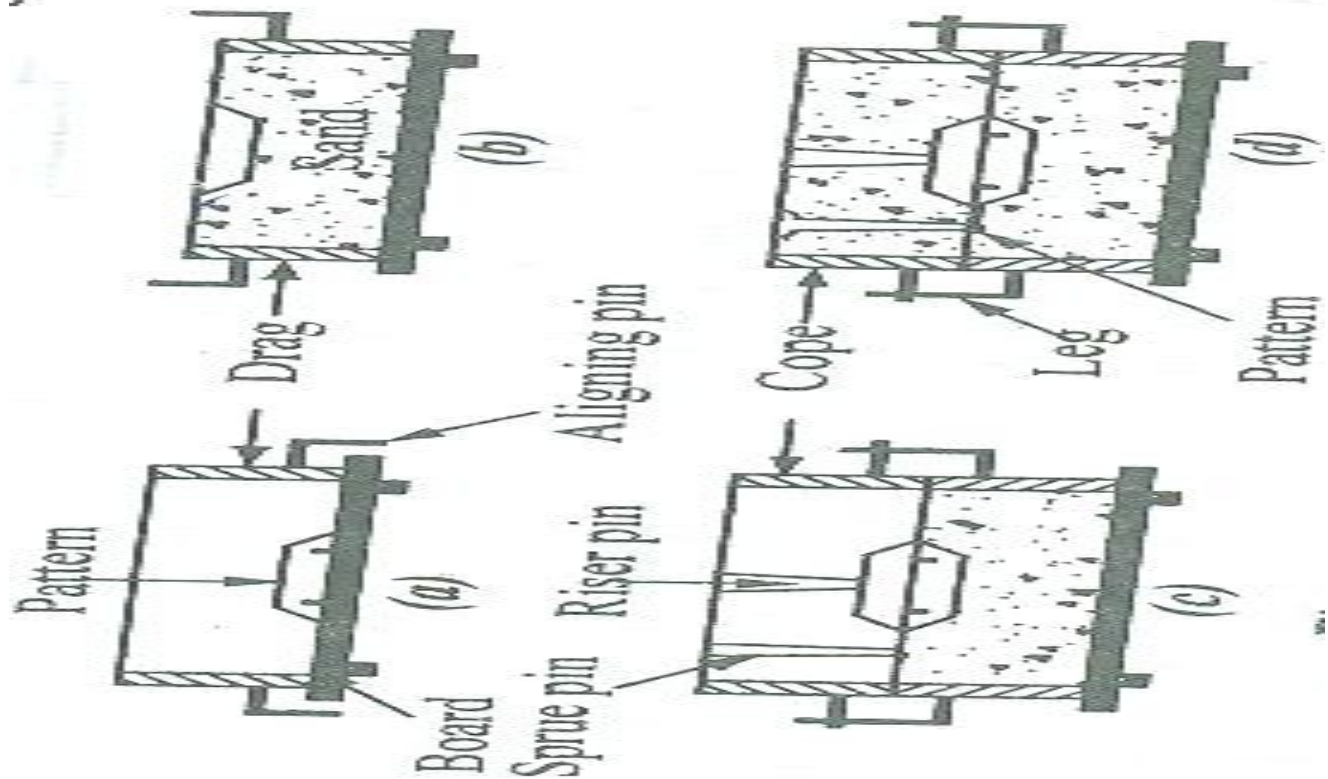
- Pour at correct temperature.
- Use sufficient molten metal.

8. a Figure shows the cross section of a control component ( having a flange and an axial hole).





9. Describe briefly, with sketches, the steps involved in making a sand mould to cast this component. Sketch also the shape of the casting as soon as it removed from the mould.(AU MAY-JUNE 2012, 2014)



The procedure for making green sand mould (floor or bench molding method) is explained below:

1. Here , we are using single piece pattern. The single piece pattern is placed at center of the molding board as shown in figure (a)

2. The drag box is placed around the pattern. Dowel pins are connected on the drag box
3. 20 mm layer of facing sand is first placed around the pattern and then the drag box is filled up with green sand
4. Sufficient ramming is done by the peen end of the hand rammer.
5. Excess sand is removed by strike off bar.
6. Vent holes are made by vent wire which is used to escape the steam and gases produced during pouring.
7. The top surface is made smooth by trowel.
8. Then the drag is tilted upside down as shown in fig (b)
9. The parting sand is sprinkled over the surface of green sand to avoid sticking of sand on cope with the sand on drag.
10. Cope box is placed correctly in position on the drag using the dowel pins as shown in fig (c)
11. Raiser pin and sprue pin are placed in correct position.
12. The operation of filling, ramming and venting of the sand on cope are done similar to that of drag.
13. Sprue pin or raiser pin are removed
14. Cope and drag box are separated.
15. Then pattern piece are withdrawn slowly.
16. A gate is cut on the top surface of the drag. It should be exactly below the sprue on the cope.
17. Finally, the cope and drag are assembled. Weight is placed on the cope to prevent the cope from floating up when the molten metal is poured. Now, the mould is ready for pouring.

**10. Explain the steps involved in “Lost wax process “,with suitable sketches. (May/ June 2012, Nov/Dec-2013)**

The molten metal is poured in already made mould cavity by melting the mould pattern in the mould itself. When the wax pattern is heated, it will be melted and disposed of from the mould called "Lost wax process". Before making the mould, first the wax pattern has to prepare from the master pattern.

Various steps involved in lost wax process:

1. The master pattern is prepared by casting process. It may be made of brass, aluminium alloy or steel metal shrinkage and wax allowances are provided on the master pattern.
2. A composite die is used for making master pattern. The die is made of low-melting alloy such as bismuth alloys, aluminium, CI etc. Master pattern die cavity is formed by machining process. Generally split type cavities are formed.
3. First, halves of die cavities are clamped together. Molten wax is injected under the pressure of about 4 bar to the die cavity. Die cavities are preheated to avoid immediate solidification of wax. If it is like this, partial filling of die cavity take place. Polystyrene, polythenes patterns are made at 35bar with higher temperature.
4. If the size of the wax pattern is large several small wax patterns are first prepared and assembled together with a gating system along with central spure. Assembling various small wax patterns are welded by using heated tools known as cluster.
5. The assembled wax patterns have to be smoothened/ super finished before putting into operation. This is done in two stages.

### Stage 1:

First, slurry is made by mixing fine silica either with water or ethyl silicate. Then wax pattern are dipped in this prepared slurry to give primary coating of about 1mm thickness. It provides the improved surface quality to wax patterns. Then wax pattern is dried.

### Stage 2:

In this stage, first ceramic slurry is prepared by using refractory material like silica and binder like gypsum. The gypsum is purely water-based sodium silicate. Wax, a solid type mould is placed over the assembled wax patterns. Then the ceramic slurry is poured over these assembled patterns

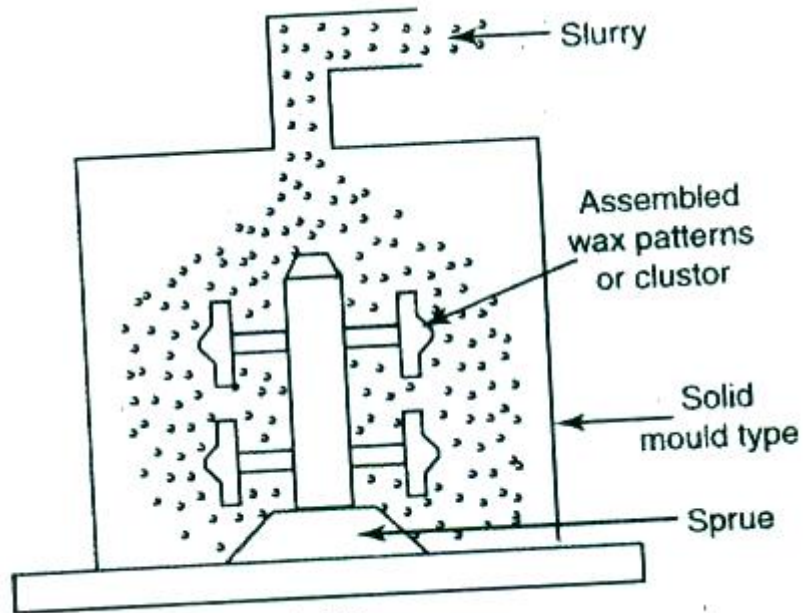


Fig 1.73

1. After applying coating, the mould is prepared using assembled wax pattern called cluster. Next, the mould made along with wax pattern dried in air for about 2 to 3hrs. then baking of patterns is done in an oven for 2hours for melting the wax patterns. When the heating temperature reaches about 100 to 120<sup>o</sup>C, the wax will start to melt. Finally, the melted wax will flow out through the sprue in molten form.
2. Again, the entire mould is transferred to heating furnace. First the mould is held at 150<sup>o</sup>C for further drying. Next, the heating is continued about 800 to 900<sup>o</sup>C to vaporize remaining wax inside the mould cavity. This preheated mould is used to fill mould cavity without partial filling due to solidification of molten metal, while pouring through the sprue. Then, it is allowed to solidify by cooling.
3. After solidification is over, the casting are removed from the mould by shaking out. At that time, the fragile material of mould will break. Then gates and sprue called runner are removed usually by machining.
4. Finally, the casting are cleaned and inspected to detect casting defects.

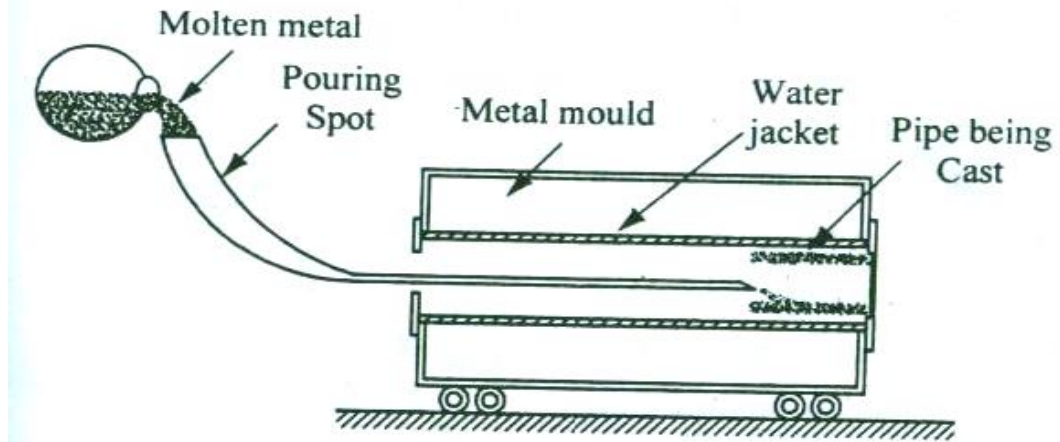
### 11. Write short notes on following: (May/ June 2012, Nov/Dec-2013)(Nov/Dec-2018)

#### (1) Ceramic mould

- In this method, first the ceramic slurry is prepared by mixing fine grained refractory powders of zircon ( $ZrSiO_4$ ) alumina ( $Al_2O_3$ ), fused silica ( $SiO_2$ ) and patented bending agents.
- Then this slurry is applied over the pattern surfaces to form thin coating around it. After applying coating on the pattern, it is baked in a less expensive fire clay. After this, the pattern is removed out from the mould and it is transferred to an oven for further heating mould about  $1000^{\circ}C$ .
- Then the molten metal is poured in the mould cavity through the sprue to produce castings.
- In this case also, the preheated mould is used during pouring of molten metal. As a result, the partial filling of molding is completely eliminated due to solidification of molten metal.
- This type of mould casting method is mainly used for all materials using better ingredients in slurry.

**(2) Centrifugal casting. (Nov/Dec-2013)(Nov/Dec-2018)**

Centrifugal casting is primarily used for making hollow castings like pipe without using core. In this process, the metal mould is made to rotate. The rotating mould is mounted on a trolley as shown in fig. The trolley move over rails. The end of the mould is closed by end cores to prevent the flow of metal. The metal is poured into mould through a long spout. The mould rotate by electric motor or mechanical means as well as moves axially on the rails. Due to centrifugal force, the molten metal is thrown to walls of the mould. The outside of the mould is water-cooled. So, the molten metal solidifies immediately.



**Fig 1.77 Centrifugal casting**

Centrifugal casting method is used for producing cylindrical and symmetrical objects.

### Applications

Components like water pipe, gears, bush bearings, fly wheel, piston rings, brake drums, Gun barrels etc.

### Advantages

1. Core is not required to produce hollow components.
2. Rate of production is high.
3. Pattern, runner, riser are not required.
4. Thin castings can be made.
5. Castings have uniform physical properties.

### Limitations

1. It is suitable only for cylindrical and symmetrical shaped castings.
2. Cost of equipment is high.

**12. Describe the various pattern allowances which can be quantitatively specified.**  
 [AU-NOV/DEC-2012;May/JUNE-2013](Nov/Dec-2018)

- Patterns are not made into the exact size of the castings to be produced.
- patterns are made slightly larger than the required castings.



- This extra size given on the pattern is called pattern allowances.
- Pattern allowances are given for the purpose of compensating the metal shrinkage to provide extra metal which is to be removed in machining, to avoid metal distortion, for easy withdrawal of pattern from mould and for rapping.
- If allowances are not given on the pattern, the casting will become smaller than the required size.

The various types of allowances are

- ❖ Shrinkage allowance
- ❖ Machining or finish allowance
- ❖ Draft or taper allowance
- ❖ Distortion or camber allowance
- ❖ Rapping or shake allowance

### SHRINKAGE ALLOWANCE

The metal shrinks on solidification and contracts further on cooling to room temperature. To compensate this, the pattern is made larger than the required casting.

This extra size provided on the pattern for metal shrinkage is called shrinkage allowance. If it is not given, the casting will become smaller.

Materials	Shrinkage allowance (mm/min)
C.I	10.4
Aluminium	17
Brass	15.3
Steel	20.8
Zinc,lead	25

### MACHINING OR FINISH ALLOWANCE

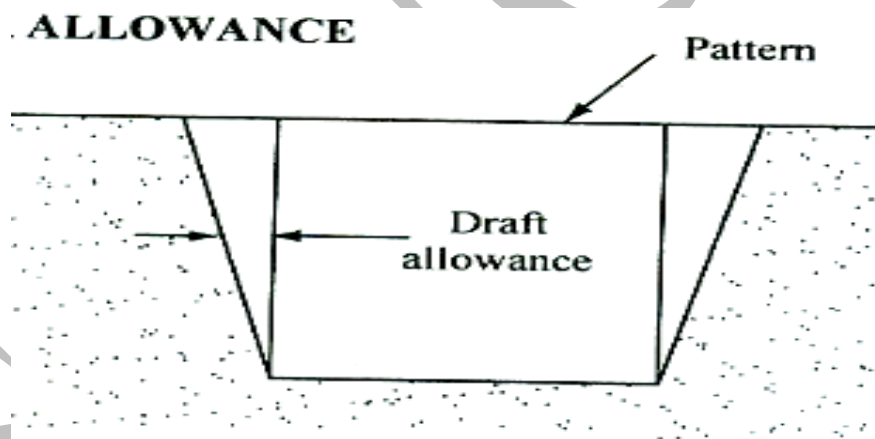
All the castings are to be machined to get the required surface finish on the metal. During machining, some of the metal is removed from the casting. For this purpose, the pattern is made larger than the required casting.

This extra size given to the pattern for machining purpose is called machining or finishing allowance. The amount of finish allowance depends on the material of the casting, size of casting, volume of production, method of molding, configuration of the casting, method of machining and degree of finishing etc.

Machining allowance is always larger for hand molding when compared to machine molding. The machining allowance for various materials is shown below.

Materials	Machining allowance	
	0-300mm	0-600mm
Cast Iron	2.5mm	4.0mm
Aluminium	1.6mm	3.2mm
Bronze	1.6mm	3.2mm
Brass	1.6mm	3.2mm
Cast steel	3mm	4.5mm

### DRAFT OR TAPER ALLOWANCE



*Fig 1.10 Draft allowance*

If the vertical faces of pattern are perpendicular to parting line, the edges of mould may damaged when the pattern is removed from the sand. Hence, the vertical faces are made into taper for as removal of pattern. This slight taper provided on the vertical sides of pattern is called draft allowance.

The amount of taper depends upon the following factors

- a. Height and size of pattern



b. molding method

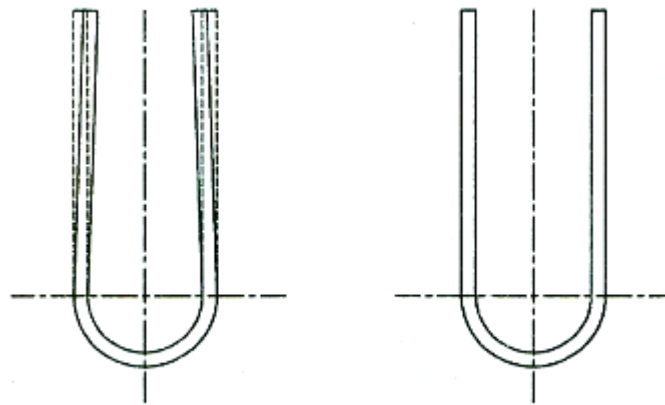
c. Mould materials

The common draft provided on the pattern is  $1^\circ$  to  $3^\circ$

Otherwise, For taper on external surface, 10 to 25 mm/m is provided.

For taper on internal surface, 40 to 65 mm/m is provided

### **DISTORTION OR CAMBER ALLOWANCE**



*Fig 1.11 Distortion allowance*

The casting may distort or warp during cooling if it is an irregular shape, flat long casting furnace and U or V shape. All surfaces do not shrink uniformly. The arms having unequal thickness are also the reason for distortion.

Due to distortion, the casting will not get the required shape. It may bend. To avoid this, the shape of the pattern is slightly bent into the opposite direction.

So, the casting neutralizes the initial distortion given on the pattern and gets the correct shape after cooling. For example, a casting of U shape may distort and legs become divergent, instead of being parallel.

To avoid this, the legs are made convergent instead of being parallel. So, the legs are become parallel after cooling.

### **RAPPING OR SHAKE ALLOWANCE**

To remove the pattern out of mould cavity, it is slightly rapped or shaken to detach it from the mould cavity. This is called rapping. So the mould cavity may become larger.

To avoid this, the pattern is made slightly smaller than the required casting.

This allowance given in the pattern is called Rapping or shakes allowance. As the allowance is subtracted from pattern dimensions, this is known as negative allowance.

**13. What are the desirable properties of molding sand for sand casting? Explain briefly each one [AU-NOV/DEC-2012]**

A good casting can be produced only with the use of good quality molding sand.

**These properties are**

7. Porosity or permeability
8. Plasticity or flow ability
9. Adhesiveness
10. Strength or cohesiveness
11. Refractoriness
12. Collapsibility

**1. Porosity or permeability:**

Permeability is a measure of molding sand by which the sand allows the steam and gases to pass through it. When molten metal is poured into the mould, steam and gases are formed due to moisture, binder and additives present in the sand.

If the gases are not removed, casting defects such as blowholes will occur. Even though we provide vent holes and riser, all of these gases will not escape through it.

To escape these gases, the molding sand should have good gas permeability

**Permeability of molding sand depends on the following factors.**

1. Quality and quantity of clays and quartz.
2. Moisture content
3. Degree of compactness.

**The following parameters which affect the permeability of molding sand.**

1. If the clay content is less the permeability will be more and vice-versa.
2. If the grain size is larger, the permeability will be more and vice versa.
3. Soft ramming (ie, less density) improves the permeability.
4. Higher the silica content on sand, lower will be the permeability.

**2. Plasticity or flow ability:**

1. The property of molding sand by which the molding sand flows around and over

the pattern, and uniformly fills the flask.

2. It gives the shape of the pattern and retains the shape after removing the pattern.
3. This property may be improved by adding clay and water to silica sand.

### **3. Adhesiveness:**

1. The property of molding sand by which it sticks or adheres to another body.
2. The molding sand should cling or stick to the sides of the molding boxes.
3. It does not fall out when the flasks are lifted and turned over. This property depends on the type and amount of binder used in the sand mix.
4. Addition of clay and moisture increases the adhesiveness.

### **4. Strength or cohesiveness:**

1. It is property of molding sand by which it sticks together.
2. A molding sand should have sufficient strength so that the mould does not collapse or get partially damaged during shifting, turning or pouring the molten metal.

#### **Strength of the molding sand depends on**

1. Grain size and shape
2. Moisture content
3. Density of sand after ramming strength is increased with increasing density, clay content and decreased size of sand grains.

### **5. Refractoriness:**

1. The property of molding sand to resist high temperature of molten metal.
2. This property mainly depends on the purity of the sand particles and size.
3. Rough and larger grain, and quartz content in molding sand increase the refractoriness.
4. Poor refractoriness will result in rough surface in casting.

### **6. Collapsibility:**

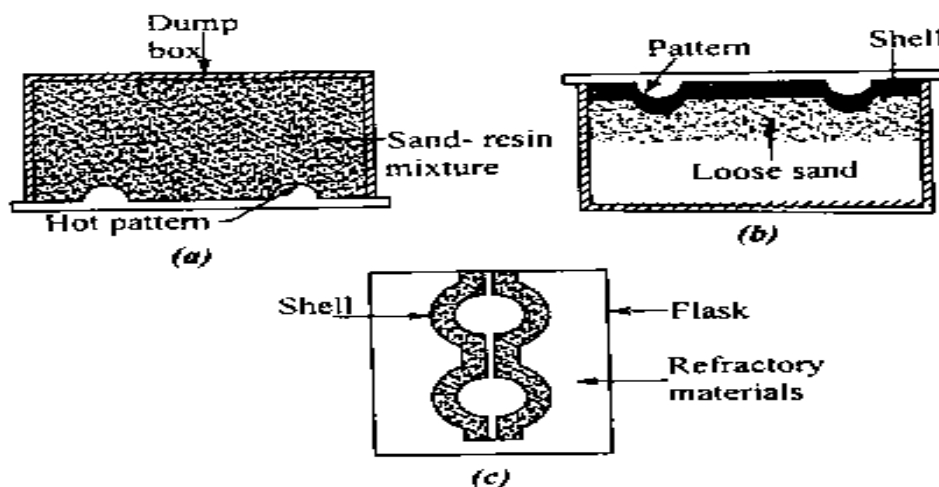
1. The property of the molding sand to decrease in volume to some extent under the compressive forces developed by the shrinkage of metal during freezing and subsequent cooling.
2. This property permits the molding sand to collapse easily after the casting solidifies.

**14. With illustrative sketches, explain the various casting defects indicating, their causes and remedies. [AU-NOV/DEC-2012]**

**13.Explain the stages of preparing shell mould, with suitable sketches. List the unique advantages of making castings in shell moulds. [AU-NOV/DEC-2012, 2013)]**

The shell mould casting is a semi-precise method for producing small castings in large numbers. The process involves the use of match plate pattern similar to cope and drag patterns which are used in green sand mould casting.

Initially the patterns are machined from copper alloys, aluminium or CI depending upon the lift of the pattern. They are made with usual allowances and polished surfaces. Then it is attached to the metal match plate.



**Fig 1.69 Shell moulding**

The mould contains 5 to 10% of phenolic resin mixed with fine dry silica. These are mixed with either dry oil or in the presence of alcohol. It should be noted that there is no water used.

The pattern is heated to about 230-600°C. Then the sand-resin mixture is either dumped or blown over its surface. Sometimes, to prevent the sticking of sand with pattern, a release agent silicone is sprayed over the hot pattern. The heated pattern melts and hardens the resin. This results in bonding the sand grains closely together and forms a shell around the pattern. After a specified time of 20-30 sec, the pattern and sand are inverted as shown in fig.1.69 (b). The thickness of the shell can be accurately controlled by the time of contact of the mixture with the heated pattern. In about 20-30 sec, we can get a normal shell thickness of 6mm. The extra sand which is not adhered to the shell is removed off. The thickness of the shell is depending on the required strength and rigidity to hold the weight of the liquid metal to be poured into the mould.

Then the mould is heated in an oven at 300°C for 15-60 sec. This curing makes the shell rigid when it can be stripped off by means of ejector pins mounted on the pattern. Thus, the formed shell constitutes one half of the mould. Two such halves, placed one over the other, make the complete mould as shown in fig.1.69(c )

While pouring the molten metal, the two halves are clamped down together by clamps or springs. After cooling and solidification, the shells are broken or shaken away from the castings.

**Applications;**

1. Used for making brake drums and bushings.
2. Cams, cam shaft, piston and piston rings can be made.
3. Used for making small pulleys, motor housing, fan blade
4. Air compressor, crankcases and cylinders, conveyors, rollers can be made.

**Advantages:**

1. A high accuracy castings with tolerances of 0.002 to 0.005 mm/min is possible.
2. Good surface finish can be obtained.
3. Complex parts can be made by this method.
4. Less sand is used compared to other methods
5. Moulds can be stored for long time.

**Limitations:**

1. Only small size of the castings can be made.
2. Serious dust and fume problem during sand and resin mixing will occur.
3. Cost is more.

4. Carbon pickup may occur in the case of steels.

**15. Describe the process of Investment casting. What process controls are needed in this case? (May/ June 2013)**

The castings obtained by this method have very smooth surfaces and possesses high dimensional accuracy. Hence, it is called as precision investment casting.

Here, the term “Investment “ means the layer of refractory material with which the pattern is covered to make the mould.

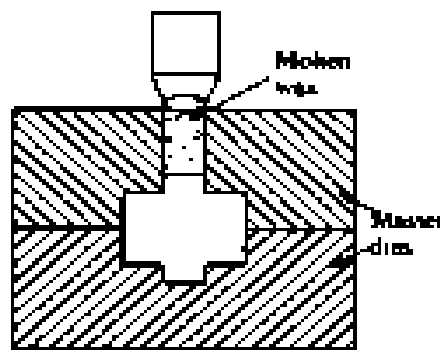


Fig 1.70 Investment casting

Like sand casting method, we can't use the mould again and again. The method involves the use of expendable (heat disposable) pattern surrounded with a shell of refractory material to form the casting mould. Casting are formed by pouring the molten metal in the mould cavities created by melting out pattern. Since the pattern made of wax is melted out and gets destroyed, that is, why the name is called as “Last-wax method”.

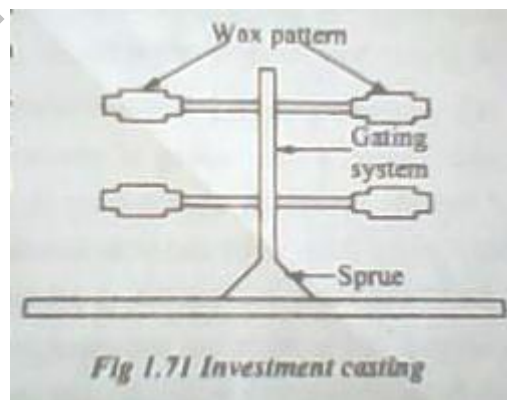
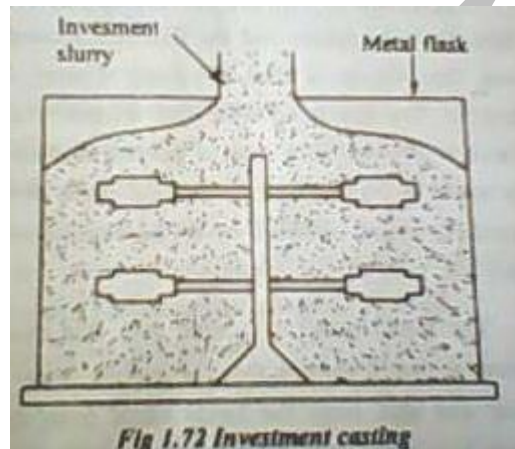


Fig 1.71 Investment casting

Initially, the master pattern which is equal to the part to be cast is made by metal that can be easily machined, such as, brass, aluminium alloy or a fusible alloy ( tin, lead and bismuth).

The dimension of the pattern is slightly larger than the actual size of the part to be made to compensate the adjustments in the die, in the wax, in the investment material. Determination of pattern dimension is very difficult job. This makes the pattern very costly.



This pattern is used to make a die out of a soft material e.g. aluminium. Therefore, wax or plastic is injected under pressure into the die to form an expendable pattern. The molten wax is slightly above its melting point and injection pressure is above 4 bars. If it is a plastic material like polystyrene, polythenes etc. the injection pressure is of the order of 35 bars with higher temperature.

This expendable pattern is rinsed in alcohol to remove grease and dirt. After drying, a thin coating of primary investment slurry is made around the wax pattern by dipping these in the slurry. Investment slurry consists of silica flour, water and some bonding agent. Then, the pattern is taken out of the slurry and rotated to produce a uniform coating, to fill inside corners and to drain out the excessive slurry. This slurry coating being in direct contact with the surfaces of the wax patterns will determine the surface quality of the casting. Sometimes, a number of expendable patterns are assembled as a 'tree' for economy as shown in fig.

Finally, fine-grain silica sand is sprinkled over the wet slurry surface. Thus the produced coating on the expendable pattern after drying is called pre-coat.



The pattern with the pre coat is then placed in a metal container type flask. Both the pattern and flask are secured to the base by molten wax. Then, the can is filled with slurry of heavy, self-hardening refractory material. This material sets in after a lapse of 24 hrs when the flask is placed in an oven. Thus, most of the wax or plastic melts and flows out of the mould by leaving a cavity with the shape of the intended casting.

**16. Briefly explain the Principle, operation, advantages, disadvantages and application of CO<sub>2</sub> molding. (May/ June 2013)(Nov/Dec-2018)**

**Principle:**

**Co<sub>2</sub> Casting** is a kind of sand casting process. In this process the sand molding mixture is hardened by blowing gas over over the mold. This process is favoured by hobby metal casters because a lot of cost cutting can be done. In addition, one can be sure of getting dimensionally accurate castings with fine surface finish. But, this process is not economical than green sand casting process.

**Operation:**

The Mold for **Co<sub>2</sub> Casting** is made of a mixture of sand and liquid silicate binder which is hardened by passing Co<sub>2</sub> gas over the mold. The equipment of the molding process include Co<sub>2</sub> cylinder, regulator, hoses and hand held applicator gun or nozzle. Carbon di oxide molding deliver great accuracy in production.

Any existing pattern can be used for the molding purpose which can be placed in the mold before the mold is hardened. This method helps in producing strong mold and cores that can be used for high end applications. If the process is carefully executed then casting can be as precise as produced by the shell casting method.

Carbon di oxide casting is favored both by the commercial foundry men and hobbyist for a number of reasons. In commercial operations, foundry men can assure customers of affordable castings which require less machining.

The molding process which can be fully automated is generally used for casting process that require speed, high production runs and flexibility. In home foundries this is one of the simplest process that improves the casting quality .



**Applications:**

**Co2 casting** process is ideal where speed and flexibility is the prime requirement. molds and cores of a varied sizes and shapes can be molded by this process.

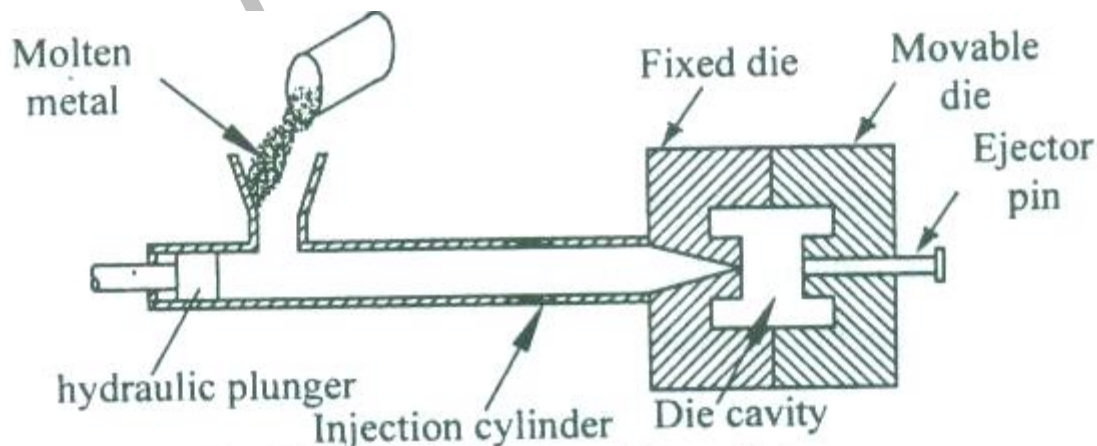
**Advantages:**

This process has many advantages in comparison to other forms of castings some of them are as follows:

- Compared to other casting methods cores and molds are strong
- Reduces fuel cost since gas is used instead of to other costly heating generating elements
- Reduces large requirement for number of mold boxes and core dryers
- Provides great dimensional tolerance and accuracy in production
- Moisture is completely eliminated from the molding sand
- This process can be fully automated.

**17. Describe with a neat sketch of cold chamber die casting machine. Give its Advantages and Limitations. (May/ June 2013)**

In cold chamber die casting, the metal melting unit is not an integral part of the machine. The metal is melted in a separate furnace and brought to the machine for pouring. The process is shown in fig



**Fig 1.75 Cold chamber die casting**

The machine has a cold chamber of cylindrical shape with a hydraulic plunger. A measured quantity of molten metal is poured into the injection cylinder. Then the plunger move to the right and force the molten metal into the die cavity. As the die is water-cooled, immediate solidification of molten metal take place. Then the dies are separated. The finished casting is removed by ejector pin.

### **Application**

1. Household equipments like washing machine parts, vacuum cleaner body, fan case, store parts etc.
2. Automobile parts like fuel pump, carburetor body, horn, wiper and crank case.
3. Component for telephone, television sets, speakers, microphones, record players etc.
4. Toys like pistols, electric trains, model aircrafts etc

### **Advantages**

1. Castings with very good surface finish can be made.
2. Rate of production is high
3. Castings with varying thickness wall can be made.
4. There is no possibility of sand inclusions.
5. Casting defects are less
6. It can be stored and used for long time.
7. The process depends on the metal to be cast.

### **Limitations**

1. Only small part can be made
2. Only non-ferrous metals can be cast.
3. Equipment cost is high
4. It is more suitable for mass production only.

## **18. Explain with neat blast furnace.**

### **BLAST FURNACE**

A blast furnace shown in figure ---is a type of furnace for smelting metal ore, usually iron ore. The combustion material and ore are supplied from the top while air flow

is supplied from the bottom of the chamber, so that the chemical reaction takes place, not only at the surface throughout the ore. This type of furnace is typically used for smelting iron to produce pig iron, the raw material for wrought and cast iron.

Blast furnace is named so because very high temperature developed inside it by means of forcing a blast of heated air. Its height is about 30 metres and interior diameter is of 8 metres.

### PROCESS

In this furnace the unwanted silicon and other impurities are lighter than the molten iron (pig iron) which is its main product. The furnace is built in the form of a tall, chimney – like structure lined with refractory bricks. Coke, limestone and iron ore (iron oxide) are poured in at the top.

Air is blown in through tuyers near the base. This “blast” allows combustion of the fuel. This reduces the oxide in the metal, which being heavier sinks into the bottom of the furnace. The nature of reaction takes place inside the furnace is:

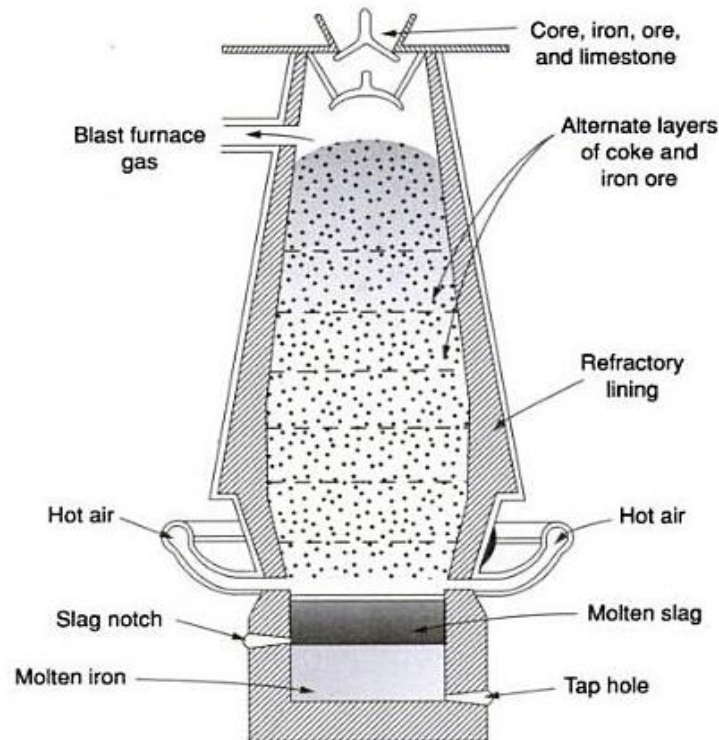


More precisely, the compressed air blown into the furnace reacts with the carbon in the fuel to produce carbon monoxide, which then mixes with the iron oxide, reacting chemically to produce iron and carbon dioxide, which leaks out of the furnace at the top. The temperature in the furnace is typically about 1500°C, which is also enough to decompose limestone (calcium carbonate) into calcium oxide and additional carbon dioxide:



The calcium oxide reacts with various acidic impurities in the iron (notably silica), forming a slag containing calcium silicate,  $\text{CaSiO}_3$  which floats on the iron.

The pig iron produced by the blast furnace is not very useful due to its high carbon content (around 4 -5 %) which makes it very brittle. It is used to make cast iron goods, often being remelted in a foundry cupola. The blast furnace remains an important part of modern production. Modern furnaces include cowper stoves to pre-heat the blast air to high temperatures in order to avoid cooling (and the having re-heat) the mix they use fairly complex systems to extract the heat from the hot carbon dioxide when it escapes from the top of the furnace, further improving efficiency. The largest blast furnaces produce around 60,000 tonnes of the iron per week.



**Fig-Blast Furnace**

**19. Explain with neat sketch with Stir casting with advantages.(Apl/May-2019)**

### STIR CASTING

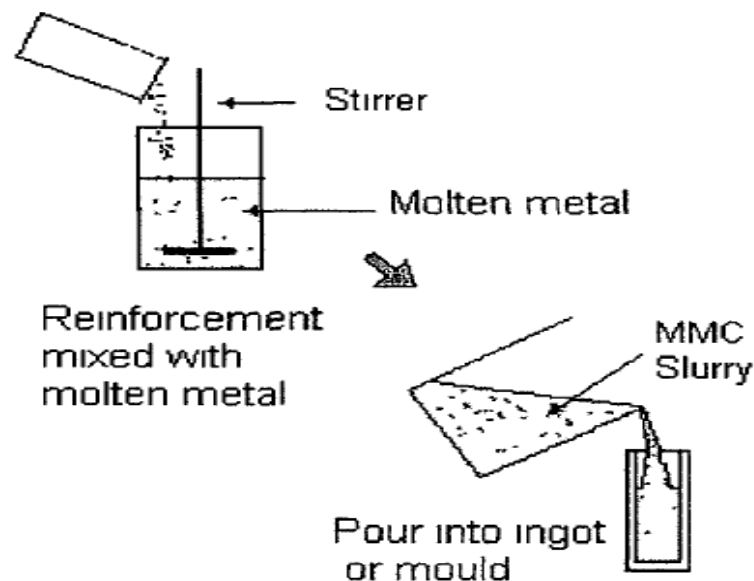
Stir casting is a liquid state method of composite materials fabrication in which a dispersed phase (ceramic particles, short fibers) is mixed with a molten matrix metal by means of mechanical stirring. Among the variety of manufacturing processes available for discontinuous metal matrix composites, stir casting is generally accepted, and currently practised commercially.

#### Process

- In general stir casting of MMCs(Metal Matrix Composites) involves producing a melt of the selected matrix material, followed by the introduction of a reinforcing material into the melt, obtaining a suitable dispersion through stirring.

- The next step is the solidification of the melt containing suspended particles to obtain the desired distribution of the dispersed phase in the cast matrix. The schematic diagram of this process is as shown in Figure.
- In composites produced by this method, particle distribution changes significantly depending on process parameters during both the melt and solidification stages of the process.

The addition of particles to the melt drastically changes the viscosity of the melt, and this has implications for casting processes. It is important that solidification occurs before appreciable settling is allowed to take place.



**Fig-Stir Casting**

**Advantage:**

- Its advantages lie in its simplicity, flexibility and applicability to large scale production and, because in principle it allows a conventional metal processing route to be used, and its low cost.
- This liquid metallurgy technique is the most economical of all the available routes for metal matrix composite production allows very large sized components to be fabricated, and is able to sustain high productivity rates.

- The cost of preparing composites materials using a casting method is about one-third to one-half that of a competitive method, and for high volume production, there shall be a possibility for further reduction of cost to the extent of one-tenth

## 20. MELTING FURNACES

Various types of melting furnace are used in foundry shop. The type of furnace used depends upon the type of metal and the quantity of metal to be melted.

The melting furnace used in foundries is

1. Cupola furnace-For cast iron
  2. Open hearth furnace –For steel
  3. Crucible furnace-For non-ferrous metal
- a. Pit type furnace
  - b. Coke fired stationary furnace
  - c. Oil fired tilting furnace
4. Pot furnace
  5. Electric furnace
- a. Direct arc furnace
  - b. Indirect arc furnace
  - c. Induction furnace.

## 21. Explain the constructional features of Cupola Furnace with Neat sketch?(Nov/Dec-2018)

This type of furnace is used for melting cast iron.

### Construction:

It is a vertical, cylindrical shell made of 10mm thick steel plate. It is lined with refractory bricks inside. Two bottom doors close the bottom of the cupola. A sand bed is laid over the bottom doors sloping towards the tap hole. Molten metal stays over this bed.

The legs are set at the bottom of the furnace using concrete. There is a tap hole for taking molten metal. A plug made of clay closes the tap hole. The slag hole is provided in the shell above the tap hole. The slag hole is provided in the shell above the tap hole. The slag floating over the molten metal is removed through this slag hole.

The opening called tuyeres are provided one meter above the bottom. Fuel is supplied through these tuyeres for making complete combustion of fuel. There is a wind box and blower for the supply of air into the furnace. For charging metal and fuel into the furnace a separate charging door is made.

**Preparation:**

The slag and waste from previous melting are cleaned. Broken bricks are repaired or replaced if necessary. Then bottom doors are closed. A sand bed with sloping towards tap hole is prepared upto a height of 200 mm.

A tap hole is formed and lined with clay. Then a slag hole is prepared. Finally, the cupola is dried thoroughly.

**Firing:**

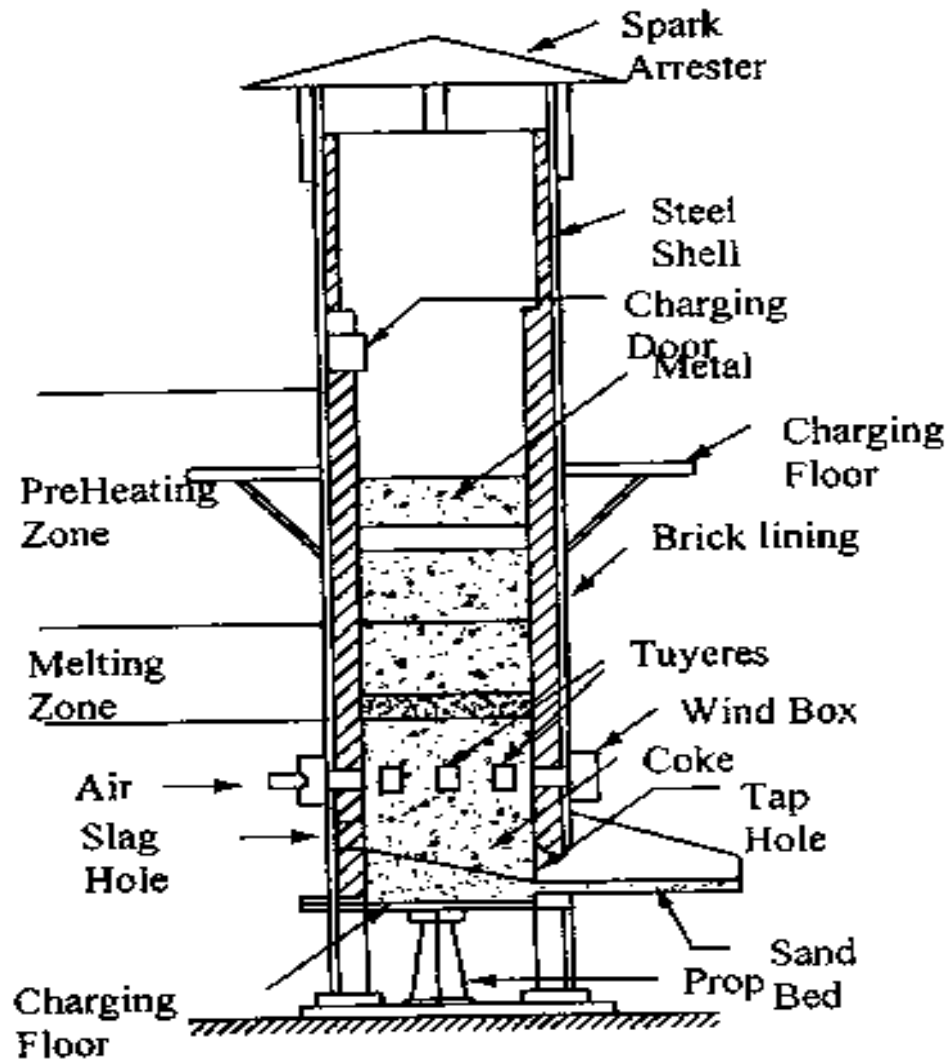
Oil waste and wooden pieces are placed at the bottom and the fire is started. Now sufficient amount of air is supplied. When the wood starts burning. The coke is charged at several portions. Now, the coke burns.

The blast is turned off. Again coke is added up to the level of bed charge. Then the coke is allowed to burn for half an hour. Finally, the charging is done through the charging door.

**Charging and Melting:**

Pig iron and iron scrap are charged into the furnace through the charging door. Then coke is charged alternatively. Limestone is added to the charge to remove impurities and also to





**Fig 1.62 Cupola furnace**

ensure thorough mixing of molten metal. The ratio of pig iron to limestone and pig iron to coke are 25:1 and 10:1 respectively. The cupola is fully charged. Then the iron is soaked for one hour. After that the blast is turned on. Molten metal will begin to collect at the sand bed. After melting enough quantity of molten metal, clay plug is removed and collected in ladles.

Then the molten metal can be directly poured into moulds. The floating slag on the top layer of the molten metal is tapped out through the slag hole. Again the furnace should be charged to the full level for repeating the same procedure.



At the end of the cupola is shut off by stopping the air blast. Then the remaining molten metal is removed, the bottom doors are opened, the wastes are dropped down and they are quenched by water.

**Application:** Cupola is used to melt cast iron.

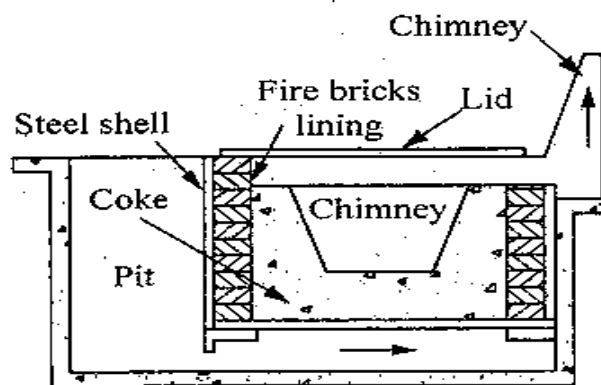
**Advantages:**

1. Initial cost is comparatively lower than other type of furnaces.
2. It is simple in design.
3. It requires less floor area

**CRUCIBLE FURNACE:**

The metal is melted in the crucible. It is made up of silicon carbide, graphite or other refractory materials. Generally it is used for melting non ferrous metals and low melting point alloys. The fuel used may be oil, gas or coke. The capacities range from 30 to 150kg.

**PIT FURNACE**



*Fig 1.63 Pit furnace*

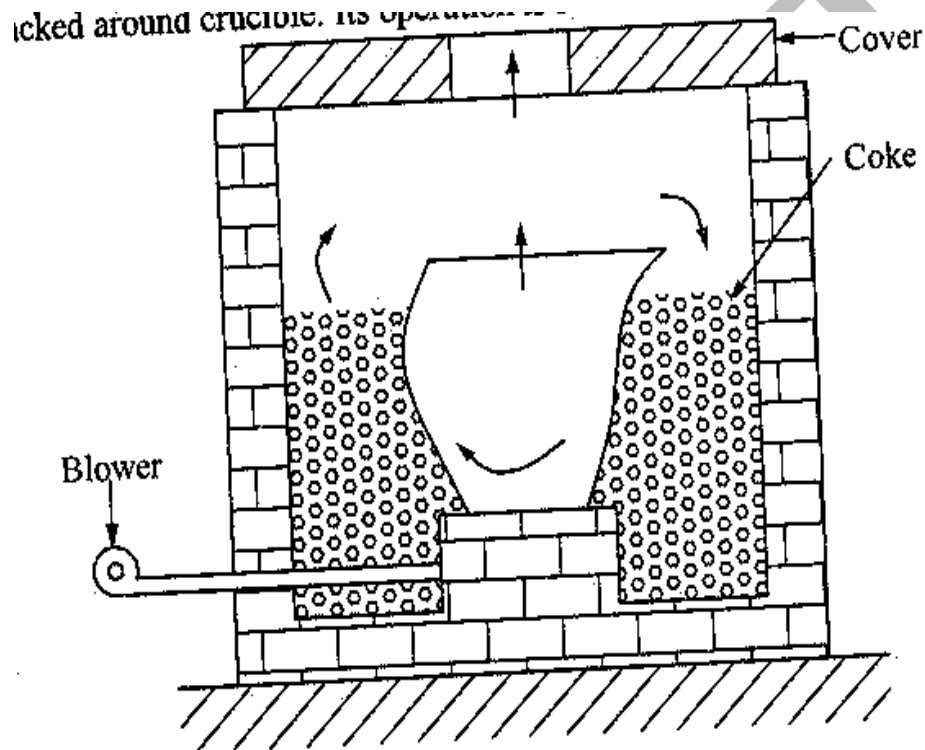
The crucible is placed in a pit below the ground level. It is usually fired with coke. The furnace is made of steel shell with a grate and pit at its bottom. The steel shell above the grate is fired with firebricks. A chimney provides natural draught. The metal is placed in the crucible. The metal charge is pig iron, foundry returns and broken castings. The coke is placed around and above the crucible. The fuel is ignited and allowed to burn. After reaching maximum combustion, the coke above the crucible is shifted to sides. Then its top is covered with a lid. A blower may be used to provide necessary air. After melting the metal,

the lid is removed. The crucible is lifted using tongs. Then it is taken to the place of pouring.

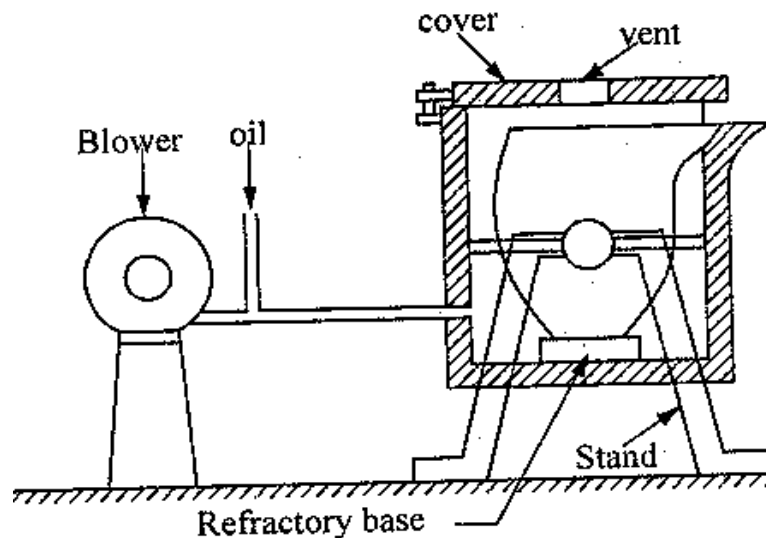
### APPLICATIONS:

It is used for melting cast iron and non ferrous metals and alloys in small quantity

### COKE FIRED STATIONARY FURNACE



The furnace is erected above the ground level. The furnace is made of steel shell lined with fire bricks. A blower is used to create draught coke is packed around crucible. Its operation is similar to coke fired pit furnace.



**Fig 1.65 Oil fired furnace**

### **OIL FIRED TILTING FURNACE:**

The tilting furnace may be coke, oil or gas fired, Mostly oil and gas fired are used because it has more advantages. The furnace consists of steel shell. Firebrick lining is provided inside the shell. Crucible is placed centrally in such a way to form a hollow chamber. The crucible is placed on a refractory base and fixed well. A burner is mounted tangentially at the bottom of the furnace. The furnace is mounted on two pedestals. It can be tilted by a geared stand wheel. While firing, oil and air are directed through the nozzle.

The flame circulates in the hollow chamber. It heats the metal charge lying in the crucible.

#### **Advantages:**

1. It is easy to start and stop the operation.
2. It is easier to control temperature.
3. It occupies less floor area.
4. It requires less labour.
5. It provides a fast melting rate.
6. It has less contamination of work place.

## **ELECTRIC FURNACES**

Electric furnaces are used for melting steel, alloy steel, brasses etc. It is used for producing high quality castings. Because of the following reasons,

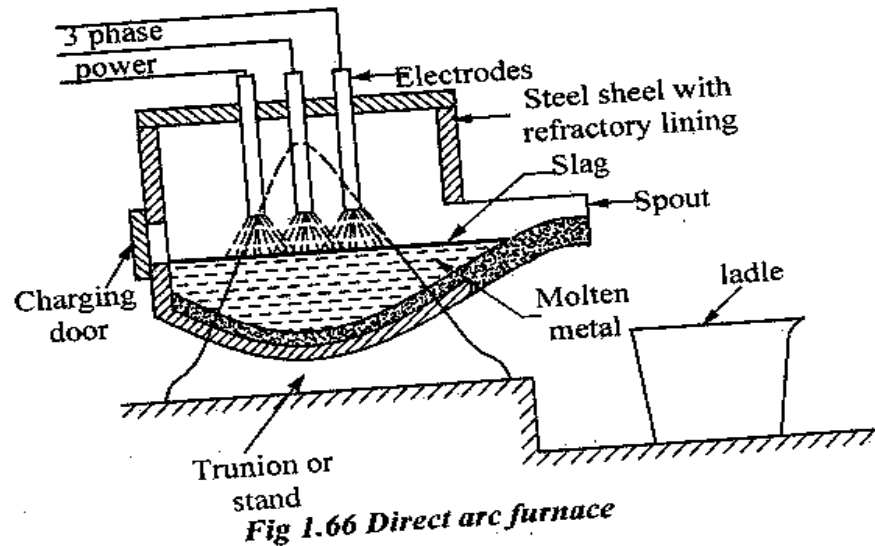
1. Oxidation losses are eliminated.
2. Furnace atmosphere can be more closely controlled
3. Alloying elements can be added without loss
4. Composition of the melt and its temperature can be accurately controlled.

The following are the different types of electric furnaces

1. Direct arc furnace
2. Indirect furnace
3. Induction furnace

### **DIRECT ARC FURNACE**

It consists of a heavy steel shell. The shell is lined with refractory brick. It has a bowl shape bottom with a detachable roof./The roof is lined with silica brick. Three graphites or carbon electrode pairs into the shell through the roof. The electrode can be raised up or down. The furnace has two spouts in which one is for molten metal and another one is for slag. The furnace is mounted in turn ions with the help of bearings. So it can be tilted backward or forward for charging, running of the slag and pouring the molten metal into the ladle.



### Working:

At first the furnace is preheated. Then the ferrous is charged with steel scraps by opening the roof or through the charging door, the electrodes are lowered down and a gap between the electrodes and metal charge surface is maintained. Then the electric supply is given to produce electric arc. The heat produced by the arc melts the metal. The electrodes may be consumed and becomes shorter. The arc gap between the electrodes and charge are maintained by automatic control. The slag formed on the top of the molten metal reduces the oxidation, refine the metal, and protects the roof and sidewalls from heat radiation.

### Applications:

It is used to melt high quality carbon steels and alloy steels.

### Advantages:

1. Thermal efficiency is high
2. Very pure metal can be obtained.
3. It can make steel directly from pig iron and steel scrap.

### Disadvantage:

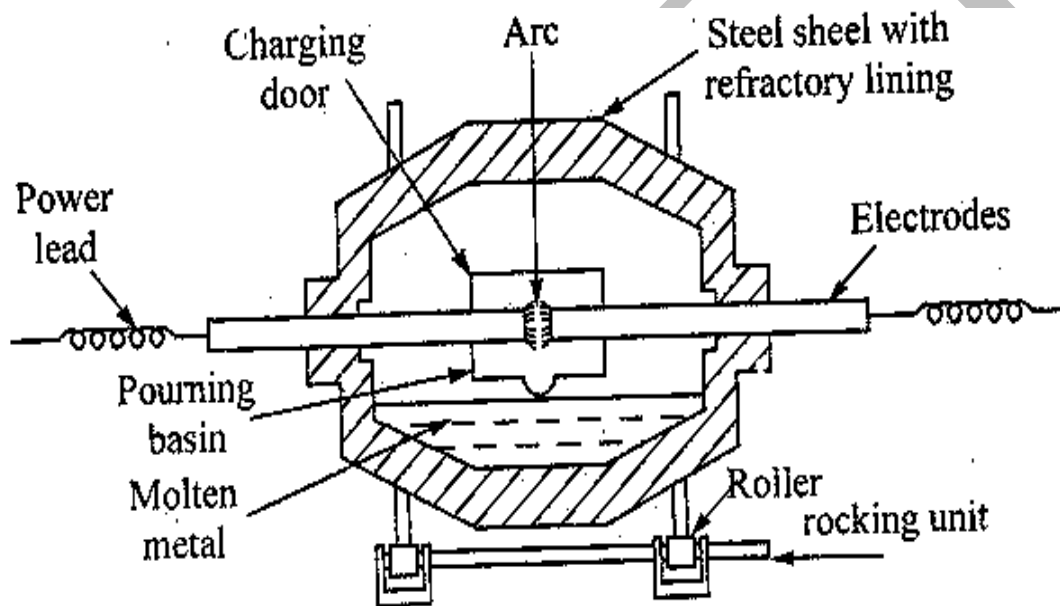
Heating cost is higher.

## INDIRECT ELECTRIC ARC FURNACE

It consists of a steel shell with refractory lining. Two graphite electrodes are mounted at opposite ends. An opening is provided at the center of shell for charging metal. A pouring spout is built up with the charging door. The furnace is mounted on the rollers. The rollers are driven to rock the furnace by a rocking drive unit.

### Working:

At first the pig iron is charged. The scrap is charged over the pig iron. With electric power on two electrodes are brought nearer to produce arc. The heat generated by arc melts the metal. Some metal is melted as soon as possible. The furnace is set to rock to and fro.



*Fig 1.67 Indirect arc furnace*

The metal melts because of

1. The heat radiation from the arc
2. The hot refractory walls of the furnace
3. Conduction from the hot linings when the furnace is tilted to pour molten metal in the ladle.

### Applications:

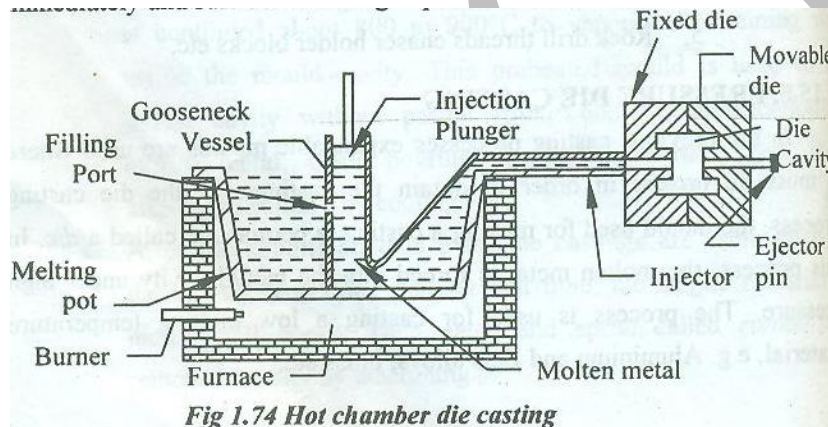
To metal cast iron, steel, copper and its alloys

**Advantages:**

1. Uniform composition of metal can be obtained.
2. Operation and control are simple.
3. Low cost scrap can be used.

**20. Explain the hot chamber die casting with figure. (May/June 2014)(Apl/May2019)  
(Nov/Dec-2018)**

In hot chamber die casting, the melting furnace is an integral part of the mould. There is a gooseneck vessel which is submerged in molten metal. There is a plunger at the top of the gooseneck vessel. When the plunger is in the upward position, the molten metal flows into the vessel through a port provided on the sidewall. When the plunger comes down, the molten metal is forced into the dies. Since, the die is cooled by water, immediately and sufficient cooling is provided for solidification.



Then the movable die is moved some distance and finished casting is removed by ejectors. The plunger and movable die are operated by hydraulic systems. The operating pressure of hydraulic plunger is  $15 \text{ MN/m}^2$ .

Hot chamber die-casting is suitable for casting of metals such as Zinc, tin and lead.

# UNIT-II JOINING PROCESS

---

## UNIT-II JOINING PROCESS

### 1. What is the principle of resistance welding? (AU MAY-JUNE 2010)

In this process there are two copper electrodes in a circuit of low resistance. The metal parts to be welded are placed between the electrodes when the current is passed through the electrodes the electrical resistance at metal joints become very high.

### 2. What is the chemical reaction occurs in Thermit welding? (AU MAY-JUNE 2010)

It is depending on the chemical reaction between iron oxide and aluminum the reaction in Thermit welding is  $8\text{Al} + 3\text{Fe}_3\text{O}_4 = 4\text{Al}_2\text{O}_3 + 9\text{Fe}$ .

### 3. Define percussion welding.(AU NOV-DEC 2010)

It is one type of resistance butt-welding process. The parts to be welded are clamped in copper jaws of welding machine.

### 4. Difference between brazing and soldering? (AU NOV-DEC 2010, MAY/JUNE 2014)

#### Brazing

It is defined “joining of two metal pieces by using a filler metal” whose liquid temperature is above  $450^\circ\text{C}$

#### Soldering

The process of joining two dissimilar metals by means of metal called solder is known as soldering whose melting temperature below  $430^\circ\text{C}$

### 5. What is the function of TIG welding? (AU MAY-JUNE 2011)

The electric arc is produced between a non- consumable tungsten electrode and work pieces.

### 6. What is the specific situation in which electro slag welding is used?

It is used for welding carbon steels alloy steel and nickel alloys.

Forging and casting being welded.

Heavy plates can be welded.

### 7. What are different methods of welding? (AU MAY-JUNE 2011)

Fusion welding – Thermit welding

Arc welding

Gas welding



## UNIT-II JOINING PROCESS

---

Plastics welding – explosive welding

Ultrasonic welding

Friction welding

Electric resistance welding

Forge welding

**8. Mention any two advantages of DC and AC welding. (AU NOV-DEC 2011)**

**DC welding**

- i. Voltage is low
- ii. Suitable for both ferrous and Non-ferrous metal

**AC welding**

- i. efficiency more
- ii. Any terminal can be connected to work or electrode

**9. When is the straight polarity used for are welding**

The positive terminal is hotter (3900°C) than the negative terminal (3200°C).

**10. What is the purpose of welding?**

- To increase the are stability
- To avoid atmosphere reaction

**11. How does MIG welding differ from TIG welding? (AU NOV-DEC 2011)**

In MIG the consumable electrode without filler material is used.

**12. State any two advantages of MIG welding.**

- 1. Efficiency is high
- 2. Process is cheaper

**13. What is the function of welding torch?**

The gases are mixed in the required proposition in a welding torch which provides the control of welding flame.

**14. Mention various types of resistance welding. (AU MAY-JUNE 2007)**

Spot welding

Seam welding

Projection welding

Shed welding

Butt welding

## UNIT-II JOINING PROCESS

---

**15. State any two application of seam welding.**

It is used to make lab proof tanks drums and radiator

It is also used for welding this sheet.

**16. What do you understand by straight polarity?**

The positive terminal connected to work piece and the negative terminal is connected to electrode.

**17. State any two advantages of TIG welding. (AU MAY/JUNE 07)**

1. No flux is required
2. Welding speed is high.

**18. What is the purpose of using inert gas in TIG welding?**

The inert gas surrounds the arc and protects the weld from atmospheric effects

**19. Define arc length.**

The distance between the tip of the electrode and the bottom of the arc creator is known as arc length.

**20. List out different metal joining.**

1. Welding
2. Riveting
3. Forging

**21. What are the functions of flux in welding electrode? (May/ June 2012, Nov/Dec 2013)**

- To act as a shield to the weld
- To prevent atmospheric reaction between molten metal and atmosphere (prevention of oxidation).

**22. What are the types of adhesives used in adhesive bonding? (MAY/ JUNE 2012)**

- Natural adhesives
- Organic adhesives
- Synthetic organic adhesives

**23. What is meant by carburizing flame in gas welding [AU-NOV/DEC-12,]**

A carburizing flame is also called reducing flame which is obtained by supplying more acetylene than oxygen. This flame has 3 zones

## UNIT-II JOINING PROCESS

---

1. Sharp inner cone
2. White intermediate cone called feather cone
3. Bluish outer cone

### **24. What is the principle of Thermit welding [AU-NOV/DEC-12, 13]**

Welding the parts by using liquid Thermit steel around the portions to be welded is called Thermit welding. Thermit welding is a fusion of welding process. In this process, neither arc is produced to heat parts or flames are used. For getting the high temperature, the exothermic reaction is used. Welding principle is the heat of the thermit reaction used for welding in plastic state and mechanical pressure is applied for the joint

### **25. What is the minimum distance maintained between two successive sport welds made by resistance welding? Why? (May/ June 2013)**

The minimum distance maintained between two successive sport welds is 0.025 mm

### **26. Write short notes on transferred and non-transferred arc in plasma arc welding. (May/ June 2013)**

#### **Transferred type**

In the transferred plasma arc, the arc is produced between the electrode (-ve) and the work (+ve).

#### **Non- Transferred type**

In the non- transferred plasma arc, the arc is produced between the electrode (-ve) and the nozzle (+ve).

### **27. Sketch the different types of oxyacetylene flames.**

- a) Neutral flame
- b) Carburizing flame and
- c) Oxidizing flame

### **28. Define weld ability.**

Weld ability is defined as the capacity of a material to be welded under fabrication conditions imposed in a specific and suitably designed structure and to perform satisfactorily in the intended service.

## UNIT-II JOINING PROCESS

---

### 29. State requirement of a good weld ability.

A metallic material with adequate weld ability should fulfill the following requirements:

- o Have full strength and toughness after welding.
- o Contribute to good weld quality even with high dilution.
- o Have unchanged corrosion resistance after welding.
- o Should not embitter after stress relieving.

### 30. How is welding classified?

Welding is classified as

- ✓ Gas welding
- ✓ Arc welding
- ✓ Resistance welding
- ✓ Solid state welding
- ✓ Thermo-chemical welding processes
- ✓ Radiant energy welding processes

### 31 Name the applications of welding.

Applications of welding are

- Aircraft construction
- Buildings
- Rail road equipment
- Ships
- Automobile construction
- Pressure vessels and tanks
- Piping and pipelines

### 32. Write in short about gas welding.

Gas welding is a fusion-welding or non-pressure welding method. It joins the metals, by using combustion heat of oxygen/air and fuel gas (acetylene, hydrogen, propane or butane) mixture.

### 33 Name the types of gas welding.

Following are the types of gas welding.

- (a) Oxy-acetylene welding
- (b) Air-acetylene welding
- (c) Oxy-hydrogen welding
- (d) Pressure gas welding

### 34. Explain the principle of oxy-acetylene welding.

When acetylene, in correct proportion, is mixed with oxygen in a welding torch and ignited, then the flame resulting at the tip of the torch is sufficiently hot to melt and join the parent metals.

### 35. Name the types of flames.

The generated flames are classified into following three types

- (a) Neutral flame (Acetylene and oxygen in equal proportion)
- (b) Oxidizing flame (Excess of oxygen)
- (c) Reducing flame or carburizing flame (Excess of acetylene)

## UNIT-II JOINING PROCESS

---

### 36. Explain neutral flame.

The flame has a nicely defined inner cone which is light blue in color and surrounded by an outer flame envelope.

### 37. What are the metals welded using neutral flame?

A neutral flame is mostly used for the welding of:

- Mild steel
- Aluminium
- Copper
- Cast iron
- Stainless steel

### 38. How do we obtain oxidizing flame using neutral flame?

If, after the neutral flame has been established, the oxygen supply is further increased then oxidizing flame will be developed.

### 39. How does the flame of an oxidizing flame look?

It is recognized by the small white cone which is shorter, much bluer in color and more pointed than neutral flame.

### 40. Where is oxidizing flame used? :

An oxidizing flame is used for :

- o Copper-base metals
- o Zinc-base metals
- o Ferrous metals such as manganese steel, cast iron, etc.

### 41. Define carburizing flame.

If the amount of oxygen supplied to the neutral flame is reduced, then the generated flame will be a carburizing flame or reducing flame i.e more content of acetylene.

### 42. Name the metals welded by carburizing flame.

This flame is generally used for:

- o Welding of low alloy steel rods
- o Non-ferrous metals
- o High carbon steel

### 43. Write down the methods of welding.

There are three typical methods that may be used which are as follows:

- ✓ Leftward or fore-hand welding method
- ✓ Rightward or back-hand welding method
- ✓ Vertical welding method

### 44. What do you mean by filler metal?

Filler metal is the material which is added to the weld pool to assist in filling the gap.

### 45. Explain the function of flux in welding.

While welding, if the metal is heated in air then the oxygen from air combines with the metal to form oxides. This results in poor quality, low weld strength hence, to avoid this difficulty a **flux** is employed during welding. It prevents the oxidation of molten metal.

## UNIT-II JOINING PROCESS

---

### 46. What are the disadvantages of flux?

Fluxes used in welding produces fumes that are irritating to the eyes, nose, throat and lungs.

### 47. Give the applications of gas welding.

Gas welding is most widely used for the following purposes:

- ✓ Joining thin materials.
- ✓ Joining most ferrous and non-ferrous metals.
- ✓ In automobile and aircraft industries.
- ✓ In sheet metal fabricating plant.

### 48. What is arc welding?(Nov/Dec-2018)(Apr/May-2019)

Electric arc welding is a fusion welding process in which welding heat is obtained from an electric arc between an electrode and the workpiece.

### 49. Define arc length and arc crater.

The distance between the centre of arc of the electrode tip and the bottom of arc crater is called as **arc length**. A small depression is formed in the base of the metal which is called as **arc crater**.

### 50 Name the equipments of gas welding

The most commonly used equipments for arc welding are as follows:

- |                              |                     |                          |
|------------------------------|---------------------|--------------------------|
| (a) A.C or D.C machine       | (b) Wire brush      | (c) Cables and connector |
| (d) Earthing clamps          | (e) Chipping hammer | (f) Wire brush           |
| (g) Helmet                   | (h) Safety goggles  | (i) Cable lug            |
| (j) Hand gloves, apron, etc. |                     |                          |

### 51 What are the functions of a coating on electrode?

- (1) The coating improves penetration and surface finish.
- (2) Suitable coating will improve metal deposition rates.
- (3) It limits spatter, produces a quite arc and easily removes slag.
- (4) Core wire melts faster than the covering, thus forming a sleeve of the coating which constricts and produces an arc with high concentrated heat.
- (5) Coating saves the welder from the radiations.

### 52 Name the types of arc welding.

The main types of arc welding are as follows:

- |                           |                                |
|---------------------------|--------------------------------|
| (a) Carbon arc welding    | (b) Shielded metal arc welding |
| (c) Submerged arc welding | (d) Gas tungsten arc welding   |
| (e) Gas metal arc welding | (f) Electro slag welding       |
| (g) Plasma arc welding    | (h) Flux cored arc welding     |
| (i) Stud arc welding      |                                |

### 53. Define SMAW.

It is an arc welding process where coalescence is produced by heating the work piece with an electric arc set up between the flux coated electrode and the work piece.

---

## UNIT-II JOINING PROCESS

---

### **54. What is submerged arc welding?**

It is an arc welding process where coalescence is produced by heating, with an electric arc set up between bare metal electrode and work piece.

### **55. Explain in short plasma arc welding.**

It is an arc welding process where coalescence is produced by the heat obtained from a constricted arc set up between a tungsten electrode and the water cooled nozzle or the work piece. The process employs two inert gases i.e. one forms the plasma arc and the second shields the plasma arc.

Filler rod may or may not be added and pressure is not required for welding.

### **56. Write about special feature of flux cored welding.**

The electrode is **flux cored** i.e. flux is contained within the hollow electrode. The flux cored electrode is coiled and supplied to the arc as a continuous wire. The flux inside the wire provides the necessary shielding of the weld pool.

### **57 Give the applications of flux cored welding**

Applications of flux core welding are

- |                                   |                                |
|-----------------------------------|--------------------------------|
| (1) Bulldozer blades, main frames | (2) Rotating frames for cranes |
|-----------------------------------|--------------------------------|

### **58. Explain resistance welding and its filler metal.**

Resistance welding is a process where coalescence is produced by the heat obtained from resistance offered by the work piece to the flow of electric current in a circuit of which the work piece is a part and by the application of pressure. Filler metal (rod) is not required during the process.

### **59. What are the factors affecting resistance welding?**

Four factors are involved in operation of resistance welding:

- o Amount of current passing through the work piece.
- o The pressure that electrodes transfer to the work piece.
- o Time during which current flows.
- o Area of electrode tip in contact with the work piece.

### **60. Write the applications of resistance welding**

This process is used for:

- o Joining of sheets, bars, rods and tubes.
- o Making of tubes and furniture.
- o Welding of aircraft and automobile parts.
- o Making of cutting tools, fuel tanks of cars, tractors, etc.

### **61 Name the types of resistance welding**

Resistance welding process includes following methods:

- |                                       |                             |
|---------------------------------------|-----------------------------|
| (a) Spot welding                      | (b) Seam welding            |
| (c) Projection welding                | (d) Percussion welding      |
| (e) Flash butt welding                | (f) Resistance butt welding |
| (g) High frequency resistance welding |                             |

## UNIT-II JOINING PROCESS

---

**62 What is adhesive bonding?**

Adhesive bonding is the process of joining materials by using adhesives. The term Adhesive includes substances such as glues, cements and other bonding agents.

**63 Write the main steps of adhesive bonding**

Main steps in adhesive bonding are

- |                           |   |
|---------------------------|---|
| (1) Surface Preparation   | (2) Applying the primer                   |
| (3) Applying the adhesive | (4) Assembling adhesive coated components |
| (5) Curing the assembly   | (6) Testing of the joints                 |

**64 Give various mediums of applying adhesives.**

Medium of applying the adhesive on the surfaces to be joined are as follows:

- |            |          |         |
|------------|----------|---------|
| o Liquid   | o Tape   | o Film  |
| o Solution | o Powder | o Paste |

**65. Name types of adhesives.**

The most commonly used adhesives are as follows:

- (a) Thermoplastic adhesives
- (b) Thermosetting adhesives

**66. Explain thermoplastic adhesives.**

Thermoplastic type adhesives soften at high temperature. They are easy to use and are employed as, air drying dispersions, emulsions or solutions that achieve their strength through the evaporation of the solvent.

**67. Explain thermosetting adhesives.**

Thermosetting adhesives, once hardened cannot be remolded and a broken joint cannot be rebounded by heating also. These types of adhesives cure or harden by chemical reactions like polymerization, condensation, vulcanization or oxidation caused by the addition of a catalyst; heat, pressure, radiations, etc.

**68. Name any four synthetic adhesives and their applications.**

Phenolic	Structural bonding, plywood
Acrylic	Bonding of plastics, glass
Epoxy	Structural bonding, concrete repair, construction industries
Olefin polymers	Laminating, packaging, book-binding
Polyurethane	Bonding of flexible to non-flexible substrate
Urea	Plywood, furniture



## UNIT-II JOINING PROCESS

---

**69 Give the applications of adhesive bonding.**

Adhesive bonding are used in following industries:

- (a) Automotive
- (b) Aircraft
- (d) Furniture
- (e) Ship-building
- (g) Shoe and apparel
- (h) Medical and dental
- (j) Railroad
- (k) Tape, etc.
- (i) Packaging Book-binding Electrical

**70. Define soldering and classify it.(Nov/Dec2018(Apl/May-2019)**

It is defined as a group of joining processes where coalescence is produced by heating to a suitable temperature and by using a filler metal having a liquids not exceeding  $427^{\circ}\text{C}$  and below the solids of base metals.

Soldering is classified as Soft solder, Hard solder.

**71. Define soft and hard soldering.**

**Soft soldering** is used in sheet metal work for joining parts that are not exposed to the high temperature action and not subjected to excessive loads and forces.

**Hard soldering** used solders which melt at higher temperatures and are stronger than those used in soft soldering.

**72. What is brazing?**

It is defined as a group of joining processes where coalescence is produced by heating to a suitable temperature and by using a filler metal having a liquidus above  $470^{\circ}\text{C}$  and below the solids of the base metal.

**73 Name the methods of brazing.**

There are various brazing methods such as:

- o Torch brazing
- o Resistance brazing
- o Immersion brazing
- o Furnace brazing

**74 What do you mean by bronze welding?**

Bronze welding does not mean the welding of bronze , but it is a welding using bronze filler rod.

**75 Name different defects in weld.**

Some common weld defects are listed below:

- (a) Cracks
- (b) Distortion
- (c) Inclusions
- (d) Porosity and blow holes
- (e) Undercutting
- (f) Overlapping
- (g) Spatter
- (h) Poor fusion
- (i) Poor weld bead appearance
- (j) Incomplete penetration

**UNIT – 2  
JOINING PROCESS**

**Operating principle, basic equipment, merits and applications of : Fusion welding processes : Gas welding - Types – Flame characteristics; Manual metal arc welding – Gas Tungsten arc welding - Gas metal arc welding – Submerged arc welding – Electro slag welding; Operating principle and applications of : Resistance welding - Plasma arc welding – Thermit welding – Electron beam welding – Friction welding and Friction Stir Welding; Brazing and soldering; Weld defects: types, causes and cure.**

**Welding**

Welding is a material joining process which produces coalescence of materials by heating them to suitable temperatures with or without the application of pressure or by the application of pressure alone, and with or without the use of filler material.

Welding is used for making permanent joints. It is used in the manufacture of automobile bodies, aircraft frames, railway wagons, machine frames, structural works, tanks, furniture, boilers, general repair work and ship building.

**Classification of welding processes****(i) Arc welding**

- Carbon arc
- Metal arc
- Metal inert gas
- Tungsten inert gas
- Plasma arc
- Submerged arc
- Electro-slag

**(ii) Gas Welding**

- Oxy-acetylene
- Air-acetylene
- Oxy-hydrogen

**iii) Resistance Welding**

- Butt
- Spot
- Seam
- Projection
- Percussion

**(iv) Thermit Welding**

**(v) Solid State Welding**

Friction  
Ultrasonic  
Diffusion  
Explosive

**(vi) Newer Welding**

Electron-beam  
Laser

**(vii) Related Process**

Oxy-acetylene cutting  
Arc cutting  
Hard facing  
Brazing  
Soldering

**Welding practice & equipment****STEPS:**

- Prepare the edges to be joined and maintain the proper position
- Open the acetylene valve and ignite the gas at tip of the torch
- Hold the torch at about 45deg to the work piece plane
- Inner flame near the work piece and filler rod at about 30 – 40 deg
- Touch filler rod at the joint and control the movement according to the flow of the material

**Two Basic Types of AW Electrodes**

Consumable – consumed during welding process  
Source of filler metal in arc welding  
Non consumable – not consumed during welding process  
Filler metal must be added separately

**Consumable Electrodes****Forms of consumable electrodes**

- Welding rods (a.k.a. sticks) are 9 to 18 inches and 3/8 inch or less in diameter and must be changed frequently
- Weld wire can be continuously fed from spools with long lengths of wire, avoiding frequent interruptions In both rod and wire forms, electrode is consumed by arc and added to weld joint as filler metal.

**Non consumable Electrodes**

Made of tungsten which resists melting  
Gradually depleted during welding (vaporization is principal mechanism)  
Any filler metal must be supplied by a separate wire fed into weld pool

**Flux**

- ✓ A substance that prevents formation of oxides and other contaminants in welding, or dissolves them and facilitates removal

- ✓ Provides protective atmosphere for welding
- ✓ Stabilizes arc
- ✓ Reduces spattering

**Arc welding**

Uses an electric arc to coalesce metals

Arc welding is the most common method of welding metals

Electricity travels from electrode to base metal to ground

**GAS WELDING PROCESS****GAS WELDING**

- Sound weld is obtained by selecting proper size of flame, filler material and method of moving torch
  - The temperature generated during the process is 33000c.
  - When the metal is fused, oxygen from the atmosphere and the torch combines with molten metal and forms oxides, results defective weld
  - Fluxes are added to the welded metal to remove oxides
  - Common fluxes used are made of sodium, potassium. Lithium and borax.
  - Flux can be applied as paste, powder, liquid. solid coating or gas.

**GAS WELDING EQUIPMENT**

## 1. Gas Cylinders Pressure

Oxygen – 125 kg/cm<sup>2</sup>

Acetylene – 16 kg/cm<sup>2</sup>

## 2. Regulators

Working pressure of oxygen 1 kg/cm<sup>2</sup>

Working pressure of acetylene 0.15 kg/cm<sup>2</sup>

Working pressure varies depends upon the thickness of the work pieces welded.

## 3. Pressure Gauges

## 4. Hoses

## 5. Welding torch

## 6. Check valve

## 7. Non return valve

**Types of Flames**

- Oxygen is turned on, flame immediately changes into a long white inner area (Feather) surrounded by a transparent blue envelope is called **Carburizing flame** (30000c)
  - Addition of little more oxygen give a bright whitish cone surrounded by the transparent blue envelope is called **Neutral flame** (It has a balance of fuel gas and oxygen) (32000c)
    - Used for welding steels, aluminium, copper and cast iron
    - If more oxygen is added, the cone becomes darker and more pointed, while the envelope becomes shorter and more fierce is called **Oxidizing flame**
    - Has the highest temperature about 34000c

- Used for welding brass and brazing operation

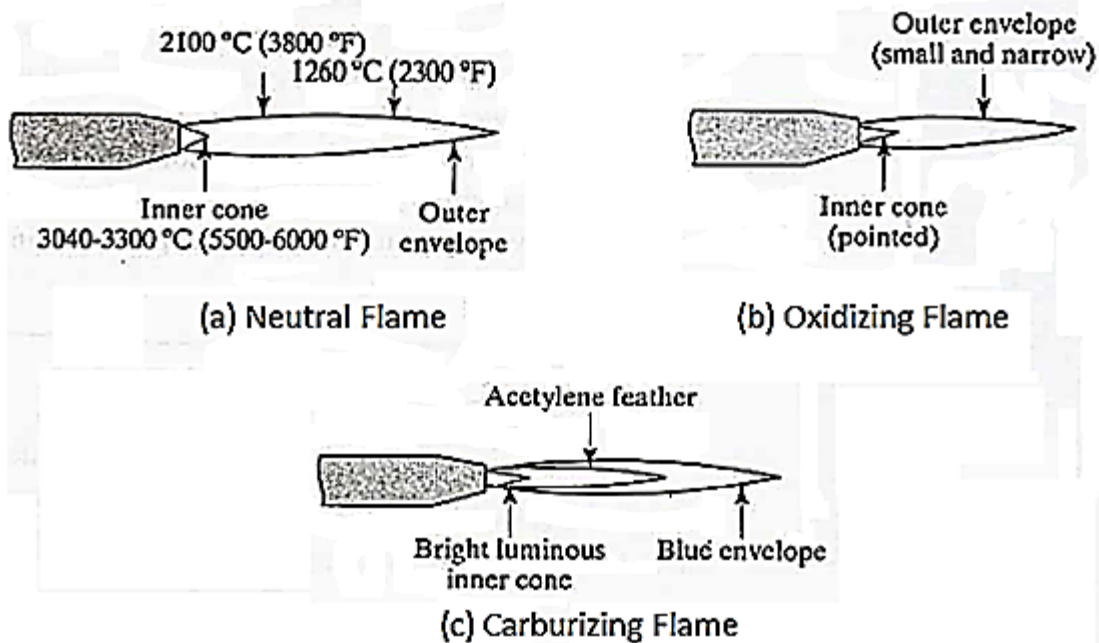


Fig.2.5 Various flame formation in Gas welding

Three basic types of oxyacetylene flames used in oxy fuel-gas welding and cutting operations:

- Neutral flame;
- oxidizing flame;
- carburizing, or reducing flame.

### Fusion welding processes

Definition: Fusion Welding is defined as melting together and coalescing materials by means of heat

- Energy is supplied by thermal or electrical means
- Fusion welds made without filler metals are known as autogenously welds

### Filler Metals:

- Additional material to weld the weld zone
- Available as rod or wire
- They can be used bare or coated with flux
- The purpose of the flux is to retard the

**1. Discuss the gas welding process and the necessary equipments needed with suitable sketches.**

[AU-NOV/DEC-2012]

**GAS WELDING PROCESS**

There are three types of gas welding process used in industries such as

1. Oxy-acetylene welding
2. Oxy-hydrogen welding,
3. Air-hydrogen welding

**OXY-ACETYLENE WELDING**

Gas welding is one type of welding process in which the edges of the metals to be welded are melted by using gas flame. No pressure is applied during welding except pressure gas welding.

The flame is produced at the tip of a welding torch. The welding heat is obtained by burning a mixture of oxygen and combustible gas. The gases are mixed in the required proportion in a welding torch which provides control for the welding flame.

The gas commonly employed for gas welding are acetylene, hydrogen, propane and butane. The most common form of gas welding is oxy-acetylene welding.

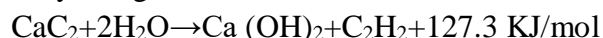
The flame only will melt the metal. So, additional metal to the weld is supplied by the filler rod. A flux is used during welding to prevent oxidation and to remove impurities. Metal 2mm to 50 mm thick are welded by gas welding. The temperature of oxy-acetylene flame in its hottest region is about 3200°C. The cost of acetylene is low. The gases O<sub>2</sub> and C<sub>2</sub> can be stored at high pressure in separate steel cylinders. But the acetylene is very harmful if it is not handled carefully.

There are two types of oxy-acetylene systems employed depending upon the manner in which acetylene is supplied for welding. These are two types of system.

1. High pressure system
2. Low pressure system

In high pressure system, both oxygen and acetylene are supplied from high-pressure cylinders. Oxygen is compressed to 120atm gauge pressure. But the acetylene cannot be compressed more than 1.5 atm like in the form of dissolved acetylene. The acetylene is dissolved in acetone under a pressure of 16 to 22 atm gauges. At normal pressure, one litre of acetone is dissolved about 25 litres of acetylene. The maximum recommended pressure of acetylene in the cylinder through a rubber hose is 1 bar. In H.P system, the pressure of acetylene at the welding torch is from 0.66 to 1 bar.

In low pressure system, the acetylene is produced at the place of welding by interaction of calcium carbide and water in acetylene generator, the chemical reaction



From the above equation, it is obvious that heat generated in this reaction is very high.

The pressure of acetylene of the torch is up to 0.06 bar. For oxygen the desired pressure in welding torch is

1. H.P system 0.1 to 3.5 bar
2. L.P system 0.5 to 3.5 bar

### AIR -ACETYLENE WELDING

This process is similar to that of oxy acetylene welding process. Here air is used instead of oxygen. The air taken from the atmosphere is compressed in a compressor and mixed with acetylene to the required proportion in the torch. This type of welding has limited use, since the temperature is lower than obtained by other gas process. It is successfully used in lead welding and many low melting temperature metals and alloy.

### OXY-HYDROGEN WELDING

This process is similar to Oxy-acetylene welding process .Hence oxygen and hydrogen gases are mixed with the required proportion for producing heat. In this process, special regular is used in metering the hydrogen gas. It was once used extensively to weld low temperature metals such as aluminium, lead and magnesium but it is not in use today because more versatile and faster welding process has been developed.

The following are the most commonly used equipment for gas welding.

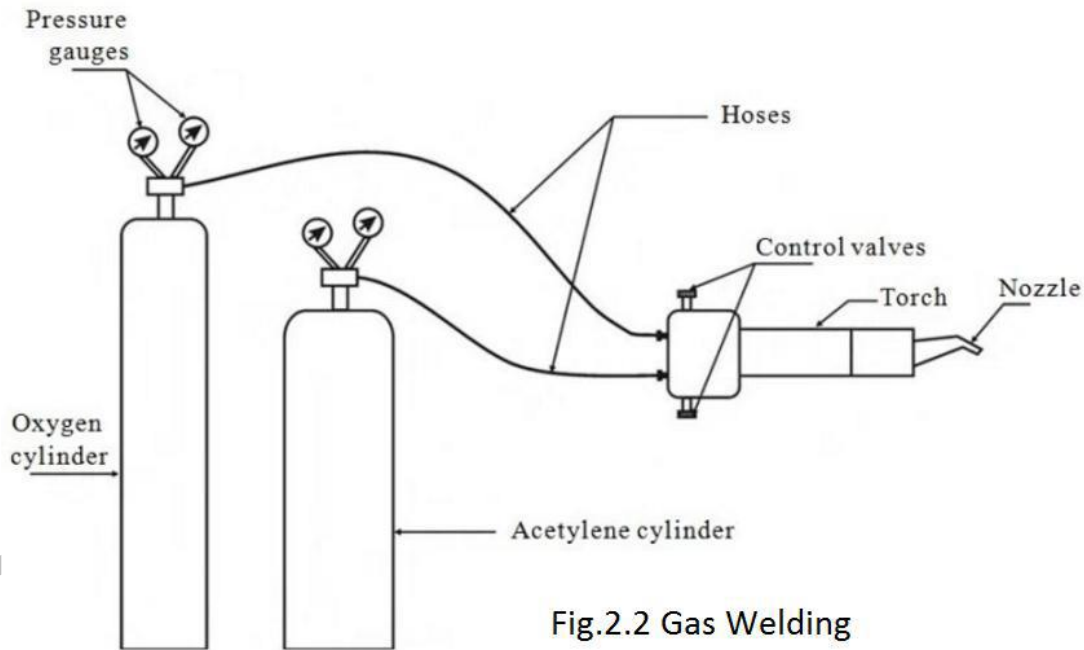


Fig.2.2 Gas Welding

#### 1. Gas cylinders

For gas welding, a head of oxygen and acetylene are used. These two gases are stored in separate cylinders. The standard colour for oxygen cylinder is black. The oxygen is stored in the cylinder at a pressure of 125 to 140 kg/cm<sup>2</sup>. Its capacity is 6.23m<sup>3</sup>. The standard colour for acetylene cylinder is maroon. It is stored at a pressure of 16 kg/cm<sup>2</sup>. Its capacity is 7.6 m<sup>3</sup>. Acetylene cylinder is fitted with fusible plug to avoid explosion.

#### 2. Pressure Regulators

Each cylinder is fitted with a pressure regulator. These regulators are used to reduce and control the working pressure of the gases. The working pressure of oxygen is between 0.7 and 2.8 kg/cm<sup>2</sup>. The



working pressure of acetylene is between 0.07 and 1.03 kg/cm<sup>2</sup>. Depending upon the thickness of the work pieces to be welded.

### 3. Pressure gauges

There are four pressure gauges provided in which two are placed on the oxygen cylinder regulators and two on acetylene cylinder regulators. Among two, one pressure gauge is for showing cylinder pressures. The other one is for showing the working pressure for welding.

### 4. Hoses

The regulator of each cylinder is connected to the torch through two long hoses. It should be flexible, strong, desirable, non process and light. Oxygen cylinder is connected with black colour hose whereas acetylene cylinder is connected with red colour hose.

### 5. Welding torch

Oxygen and Acetylene enter the torch through the hose in separate passages. Both the gases are mixed in the mixing chamber of the torch. When it is ignited, a flame will be produced at the tip of the torch called an nozzle. There are two control valves on the welding torch. They are used to control the quantity of oxygen and acetylene to adjust the flame. The nozzles or tip are made of copper or copper alloy. Tips are in different sizes depending upon the type of metal to be welded and its thickness.

There are two types of torches such as

- ✓ Equal pressure type
- ✓ Injected type

### 6. Goggles

The welding goggles are used to protect eyes from the flame heat, ultra violet and infra red rays

### 7. Welding gloves

Gloves are used to protect hand from the injury causing by heat and metal splashes.

### 8. Spark lighter

It is an igniter to start the burning of the oxy acetylene gases

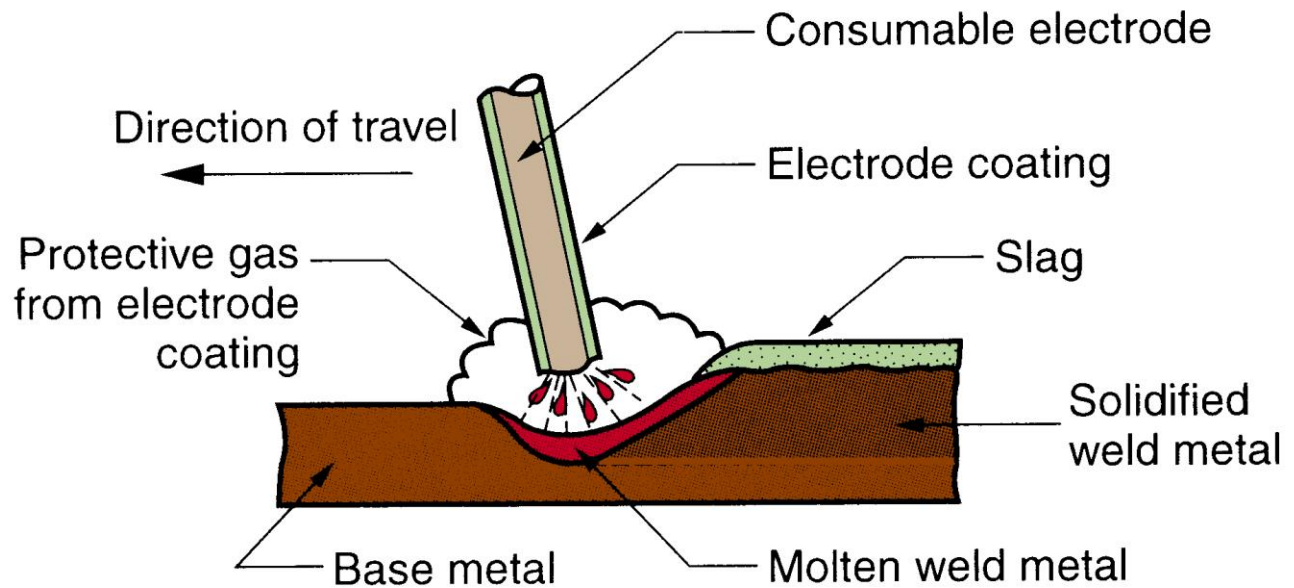
### 9. Wire brush

It is used to clean the weld joint before and after welding

## 2. Explain the metal arc welding process with a sketch. [AU-NOV/DEC-2012, 2013](Nov/Dec-2018)

The process is also called as gas metal arc welding. In this arc welding, the electric arc is produced between a consumable metal electrode and the work piece. During welding, the arc and welding zone are surrounded by an inert gas as shown in fig. Argon or helium is used as the inert gas. The surrounded air protects the weld from atmosphere. The electrode is fed continuously through welding head because during welding the electrode is melted by arc and deposited over the work piece. The welding can be done manually or automatically. Either D.C generator or A.C transformer is used for MIG welding. The current ranges from 100 to 400 A depending upon the diameter of the wire. The welding head may be either air or water-cooled depending upon the current being used.





This process is used for welding thick plates. It is used for welding aluminium, stainless steel, nickel and magnesium without weld defects.

**Advantages:**

1. No flux is required
2. High welding speed
3. Possible to weld ferrous and non-ferrous metals
4. Greater efficiency
5. produces high quality weld
6. Cheaper process

**3. Explain with a neat sketch the equipment and process of submerged arc welding. (May/ June 2013)**

This is a well established and extremely versatile method of welding. Submerged-arc welding (SAW) involves the formation of an arc between a continuously fed electrode and the work piece. A blanket of powdered flux, which generates a protective gas shield and a slag (and may also be used to add alloying elements to the weld pool), protects the weld zone. A shielding gas is not required. The arc is submerged beneath the flux blanket and is not normally visible during welding.

The flux starts depositing on the joint to be welded. Since the flux when cold is non-conductor of electricity, the arc may be struck either by touching the electrode with the job or by placing steel wool between electrode and job before switching on the welding current or by using a high frequency unit. In all cases the arc is struck under a cover of flux. Flux otherwise is insulator but once it melts due to heat of the arc, it becomes highly conductive and hence the current flow is maintained between the electrode and the job through the molten flux. The upper portion of the flux, in contact with atmosphere, which is visible remains solid granular i.e., unchanged and can be reused.

The electrode at a predetermined speed is continuously fed to the joint to be welded. In semi-automatic welding sets the welding head is moved manually along the joint where as automatic welding a

separate drive moves either the welding head over the stationary job or the job moves/rotates under the stationary welding head.

The arc length is kept constant by using the principle of a self adjusting arc i.e., if due to certain reasons arc length decreases, arc voltage will increase, arc current and therefore burn-off rate will increase thereby causing the arc to lengthen. The reverse occurs if the arc length increases than the normal.

Backing plate of steel or copper may be used to control penetration and to support large amounts of molten metal associated with the process.

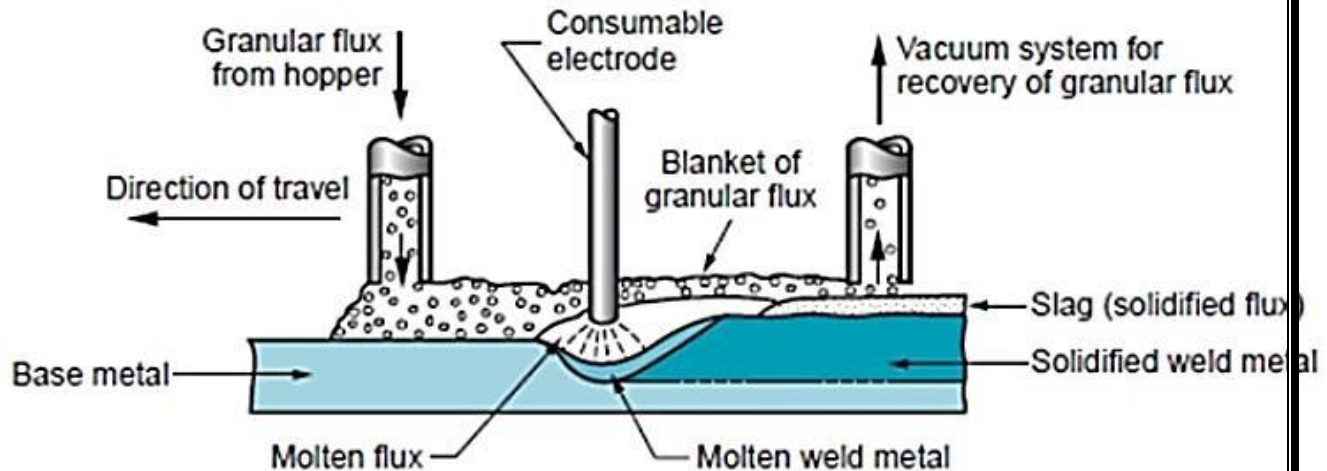


Fig.2.8 Submerged Arc Welding

#### Characteristics of submerged-arc welding

- ✓ The flux is fed into the weld zone from a hopper by gravity through a nozzle
- ✓ Prevents spatter and sparks;
- ✓ Suppresses the intense ultraviolet radiation and fumes characteristics of the SMAW.
- ✓ It acts as a thermal insulator by promoting deep penetration of heat into the work piece.
- ✓ The unused flux can be recovered, treated and reused.

#### Advantages

- ✓ High deposition rates (over 100 lb/h (45 kg/h) have been reported).
- ✓ High operating factors in mechanized applications.
- ✓ Deep weld penetration.
- ✓ Sound welds are readily made (with good process design and control).
- ✓ High speed welding of thin sheet steels up to 5 m/min (16 ft/min) is possible.
- ✓ Minimal welding fume or arc light is emitted.
- ✓ Practically no edge preparation is necessary.
- ✓ The process is suitable for both indoor and outdoor works.
- ✓ Low distortion

#### Limitations

- ✓ Limited to ferrous (steel or stainless steels) and some nickel-based alloys.
- ✓ Normally limited to the 1F, 1G, and 2F positions.
- ✓ Normally limited to long straight seams or rotated pipes or vessels.
- ✓ Requires relatively troublesome flux handling systems.
- ✓ Flux and slag residue can present a health and safety concern.
- ✓ Requires inter-pass and post weld slag removal.

**4. Explain electro gas welding with its principles and application. (Nov/Dec 2013).**

**ELECTRO-GAS WELDING**

The technique of vertical welding between water-cooled copper shoes characteristic of electro-slag welding is also used in a superficially similar process called electro-gas welding. In electro-gas welding, however, heat generation is by an electric arc which is struck from a flux-cored electrode to the molten weld pool. The flux from the flux-cored electrode forms a thin protective layer but does not give a deep-slag bath as in electro-slag welding.

Additional shielding of the weld pool is provided by a shield of carbon dioxide or argon-rich gas which is fed over the weld pool through the top of each copper shoe. Mechanically the apparatus is similar to that for the wire electrode type of electro-slag welding. Electro-gas welding can be used on thicknesses from to 3 in., although it is chiefly used at the lower end of this range, for example in shipbuilding and the site fabrication of storage tanks.

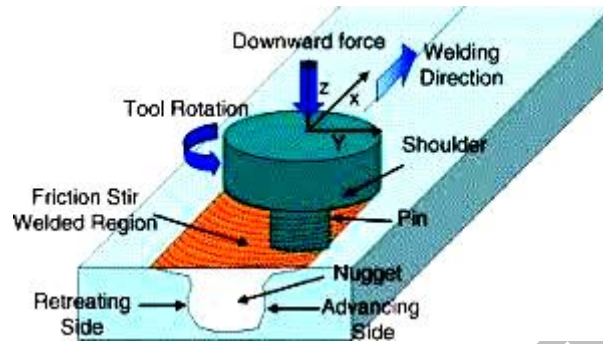
Because it is an arc-welding method and capable of speeds in excess of electro-slag welding for comparable thicknesses, the thermal effects and therefore the metallurgy in the heat-affected zone more closely resembles a sub-merged-arc weld than an electro-slag weld. For the same reason an electro-gas weld can be started without the necessity of a starting block, and if for any reason a weld run is stopped it can be re-started with less difficulty than an electro-slag weld.

**5. Explain the friction stir welding process with neat sketch.(Nov/Dec 2013).**

Friction stir welding (FSW), illustrated in Figure, is a solid state welding process in which a rotating tool is fed along the joint line between two work pieces, generating friction heat and mechanically stirring the metal to form the weld seam. This process derives its name from this stirring or mixing action. FSW differs from conventional Friction welding by the fact that friction heat is generated by a separate wear-resistant tool rather than by the parts themselves.

In friction stir welding process the rotating tool is stepped, consisting of a cylindrical shoulder and a smaller probe projecting beneath it. During welding, the shoulder rubs against the top surfaces of the two parts, developing much of the friction heat, while the probe generates additional heat by mechanically mixing the metal along the butt surfaces. The probe has a geometry designed to facilitate the mixing action. The heat produced by the combination of friction and mixing does not melt the metal but softens it to a highly plastic condition.

As the tool is fed forward along the joint, the leading surface of the rotating probe forces the metal around it and into its wake, developing forces that forge the metal into a weld seam. The shoulder serves to constrain the plasticized metal flowing around the probe.



The FSW process is used in the aerospace, automotive, railway, and shipbuilding industries. Typical applications are butt joints on large aluminium parts. Other metals, including steel, copper, and titanium, as well as polymers and composites have also been joined using FSW.

**Advantages:**

- (1) Good mechanical properties of the weld joint
- (2) Avoidance of toxic fumes, warping, shielding issues, and other problems associated with arc welding
- (3) Less distortion or shrinkage
- (4) Good weld appearance.

**Disadvantages:**

- (1) An exit hole is produced when the tool is withdrawn from the work
- (2) Heavy-duty clamping of the parts is required.

**6. Explain with neat diagram of resistance welding. (AU MAY-JUNE 2010, MAY/JUNE 2014)**

**Resistance welding**

In resistance welding, the parts to be joined are heated to plastic state by their resistance to the flow of electric current and mechanical pressure is applied to complete the weld. In this process, there are two copper electric in a circuit of low resistance the metal parts to be welded are placed between the electrodes when current is passed through the electrode, the electrical resistance at the metal joints becomes very high so, the metals are through to red hot plastic conduction.

Now, mechanical pressure is applied to complete the weld.

The electric current passes from the electrode to the work piece through the slag pool the welding flume used in electro slag welding should be cleared from impurities and oxidation.

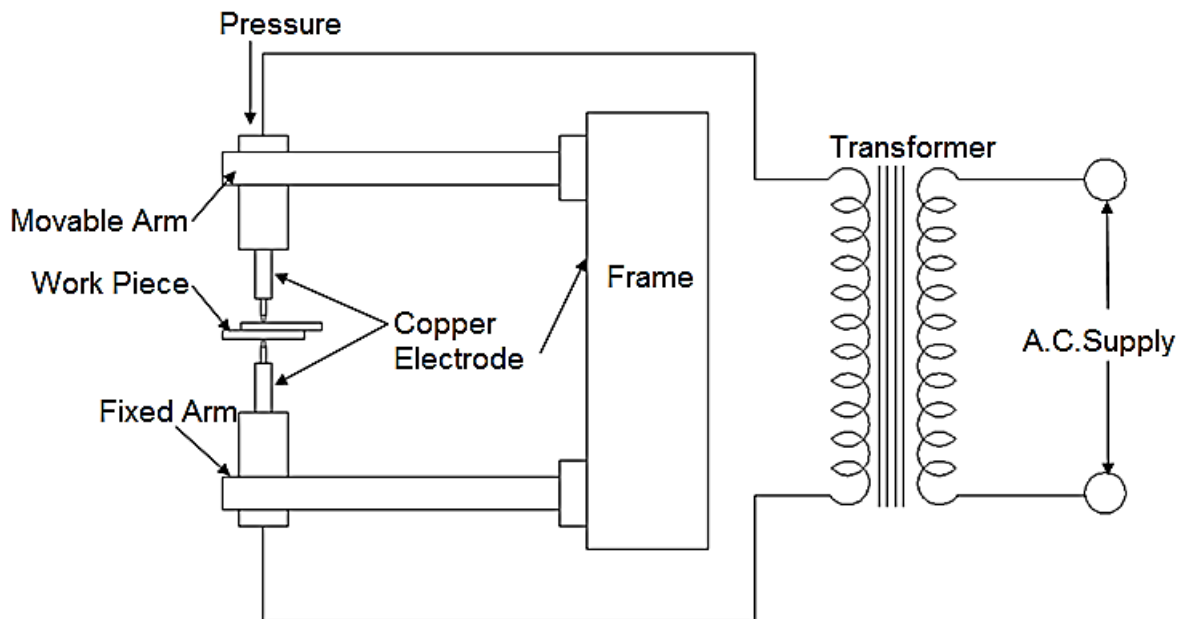


Fig. 2.10 : Resistance welding

The heat generated in the weld may be expressed by

$$=I^2RT$$

= heat

I= current in amps.

T= time of current flow

Therefore the heat developed by the current is proportional to the electric resistance of the weld.

A.C with a suitable – transformer is used for the power supply usually 4-12 rolls is used dependent on the composition, area and thickness of the metal to be welded.

**7. Explain the electro slag process. (AU MAY-JUNE 10, 12, NOV/DEC 13)(Nov/Dec-2018)**

**Principle:-**

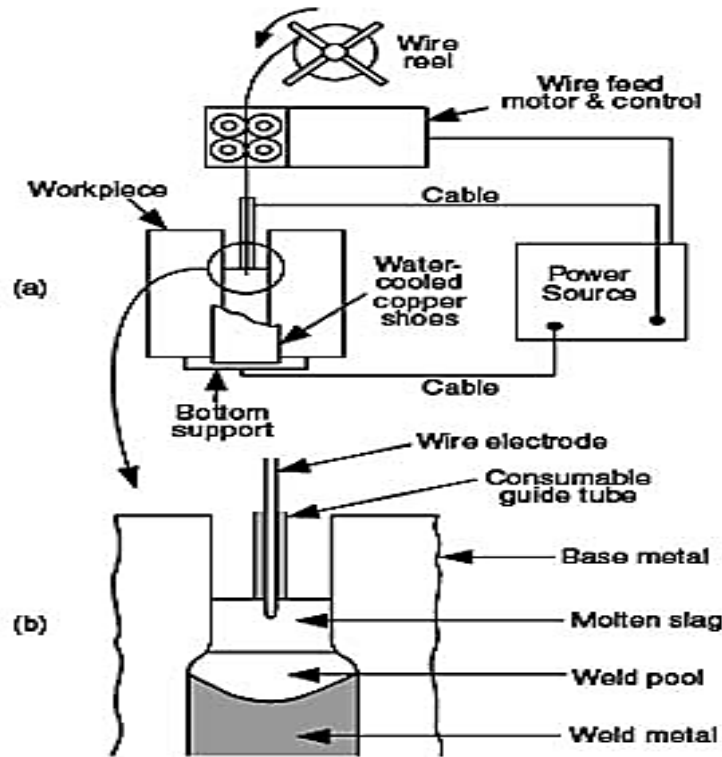
Electro slag is a welding process in which the coalescence is formed by molten slag and molten metal pool remains shielded by the molten slag.

**Working:-**

In this welding process the electric arc is struck between the electrode and work jointed by use of steel wood. Welding flux is added and melted by the use of heat flux added and further melted by the use of heat from the air.

The temperature of this slag remains between 1600 to 1900°C inside surface so this high amount of heat energy is enough for the melting the work piece and the electrode thus the weld is formed.

The electric current passes from the electrode to the work piece through the slag pool. The welding flux used in electro slag welding should be cleared from impurities oxidation.



**Fig.2.9 Electroslag welding**

**Applications:-**

- ✓ It is used for welding low alloy steels and nickel alloys.
- ✓ Forging and casting being welded
- ✓ Heavy plastic can be welded.

**Advantages:-**

- ✓ Heavy thickness metals can be welded atomically
- ✓ Low stress formation preparation of joints easier
- ✓ High deposition during the weld.
- ✓ Low distortion.

**Disadvantages:-**

- ✓ Difficult to weld cylindrical objects
- ✓ Hot gawking may occur
- ✓ Grain size becomes larger
- ✓ High cost.

**8. Explain the process of flame cutting (AU NOV-DEC 2010)**

**Introduction:-**

Flame cutting is widely used in the welding and fabrication industry for making steel parts for every thing from sky scrapers and bridges to industrial equipment and farm implements

Procedure:-



Steel can catch fire and burn just like coal, wood (or) heating coil operation is to get the steel hot enough to ignite, and the pure oxygen is used to keep firing. This is a true chemical process in which the material is not simply melted away.

Operation:-

To start a cut, the user brings a flame closer to steel plate using a cutting torch. It burns a mixture of fuel gas and oxygen to create a very hot preheats flame.

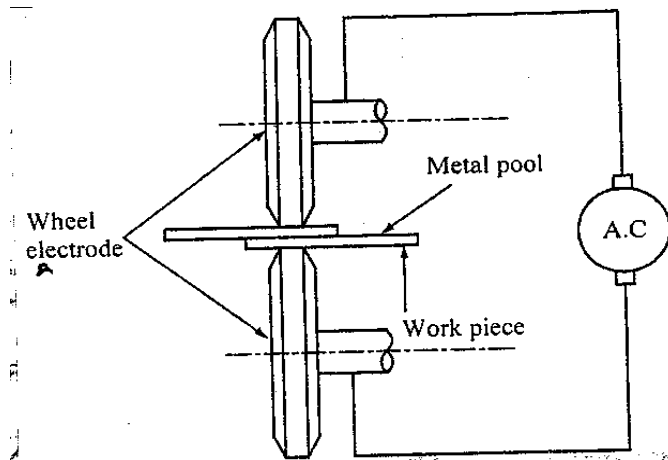
When it is hot enough an additional source of high pressure oxygen is turned on the stream will be directed at the surface of the steel at the right honest spot. The metal will start burning, at that instant, the oxygen flow it creates a hole or gauge in the metal an the way enough.

Chemical reaction:-

The chemical equation for a complete combustion of iron with oxygen is  $3\text{Fe} + 2\text{O}_2 = \text{Fe}_3\text{O}_4 + 267000\text{Kcal}$ .

Write the process of seam welding. (AU NOV-DEC 2010, 2013)

The seam welding is used to procedure, continues joint between two over lapping pieces of sheet metal the work piece are placed between two rotating wheel electrodes when electric current is passed through the electrodes. High heat is produced on the work pieces between the wheels at the same time, pressure is applied to complete the weld the work piece is continuously mould in between the wheels thus the leak proof continuous seam is achieved by supplying coolant to be electrodes finally it spends up the welding process.



Application:-

Seam welding is used to make leak proofs, tanks, drums, radiators, house hold utensils automobiles bodies etc. it is also used for welding their sheets.

**9. Explain with neat diagram of plasma arc welding. (AU MAY-JUNE 2011) [AU-NOV/DEC-2012]**

**Principle:-**

Plasma is high temperature ionized gas. it is a mixture of a neutral atoms, positively charged atoms and free elements.

When this high temperature plasma is passes through the orifice, the proportion of the ionized gas increases and plasma arc welding is formed.

### Working:-

When the high heat content plasma gas is forced through the torch orifice surrounded by a negative tungsten electrode in the form of jet. The plasma cutting forces imposes a swirl on the orifice gas flow. The arc is initiated in the beginning by supplying electrical energy between nozzle and tungsten electrode.

This will release high energy and heat. This heat is normally in between  $10,000^{\circ}\text{C}$  to  $30,000^{\circ}\text{C}$

The high amount of heat energy is used to weld the metal there are two types of plasma arc welding.

1. Transfer type
2. Non transfer type

### Transfer type:-

In transferred type, the tungsten electrode is connected to the negative terminal work piece is connected. To the positive terminal. An electric arc is maintained between the electrode and the work piece heat a co-axial flowing gas and maintain it in a plasma state.

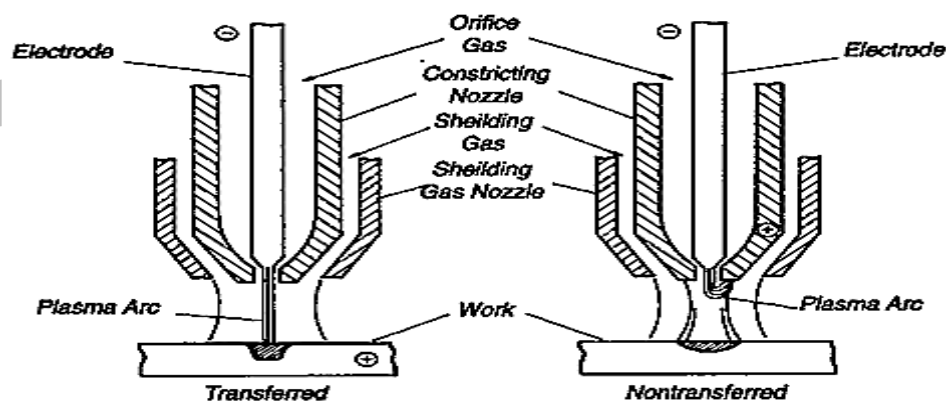


Fig. 2.17 : Plasma Arc welding



It is difficult to imitate the arc first between the work piece and the electrode for that the pilot arc is struck between the nozzle and the electrode

**Non transferred type:-**

In this type, power is directly connected with the electrode and the torch of nozzle. The electrode carries the same current.

Thus ionizing a high velocity gas that is streaming towards the work piece. The main advantages of this type are that the heat moves inside the wall and the incoming gas and outer layer remains cool.

The base metals welded by a plasma arc welding are.

1. Stainless steel
2. Titanium alloys
3. Carbon and low alloy steels
4. Copper alloys
5. Aluminium alloys

**Applications:-**

1. It is used in aerospace applications
2. It is used for high melting point metals.
3. It is used for welding titanium plates.
4. It is used in welding nickel alloys
5. It is used for tube mill application.

**Advantages:-**

1. Penetration is uniform
2. Arc stability is good.
3. High accuracy weld can be produced

**Disadvantages:-**

1. Huge noise occurs during welding

2. Gas consumption is high
3. Ultra violet radiations can affect human body.

**10. Explain with neat diagram process of laser beam welding (AU MAY-JUNE 2011)**

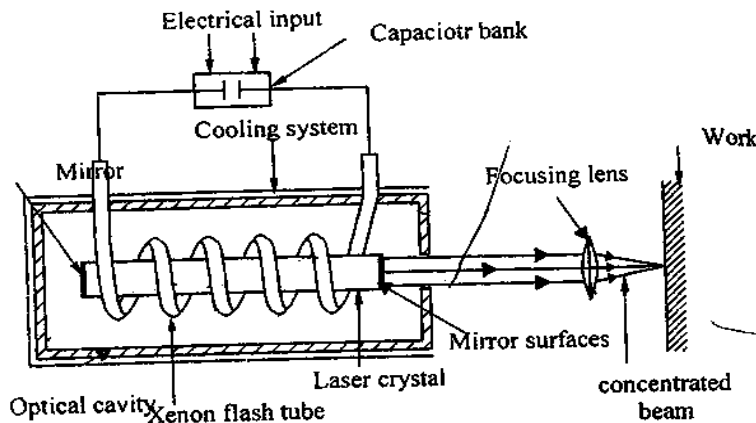
The word laser stands for light amplification by stimulated emission radiation

**Principle:-**

Light energy is converted into heat energy, here light is produced from the laser source like ruby by rod in the form of monochromatic light.

**Working:-**

Due to electrical discharge from capacitor, the flash tube converts the electrical energy into light flashers when ruby rod is exposed to the intense light flash, the chromium atoms of the crystal excited and pumped to high energy level beam this high energy level is immediately reduced to intermediate and drop to original state with the evolution of red fluorescent light.



The laser light is not only intense but also can be readily focused without loss of intensity. The laser light is focused by the focusing lens to the work piece in the form of coherent monochromatic light.

When this light energy is impacted to the work piece, it will convert into heat energy this heat energy is sufficient to melt the materials to be welded.

**Advantages:-**

1. It is used in glass and plastics
2. There is no feed of electrodes and power
3. Accuracy is greater.

**Disadvantages:-**

1. Welding process is low
2. Limited depth of weld can be done
3. It is not suitable for large production

**Applications:-**

1. Thin metals about 0.5 – 1.5 mm thick can be welded.
2. It can joint dissimilar metals.
3. It is very much useful joining metal alloys.

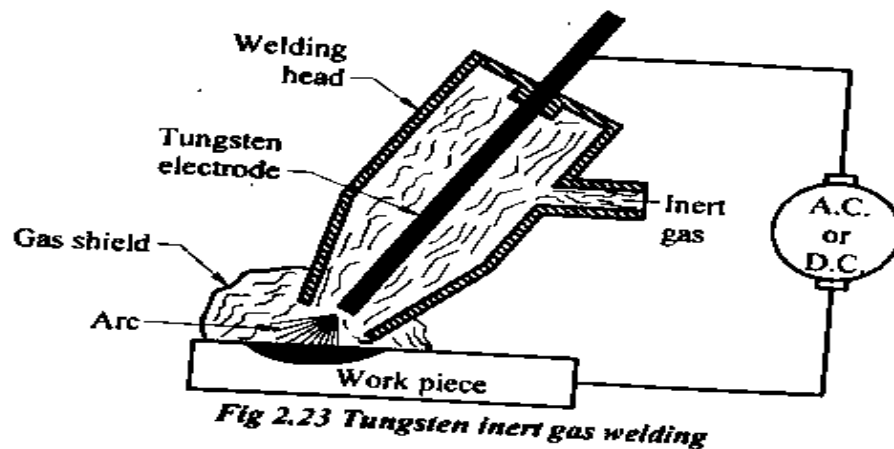
**With the help of suitable diagram, explain the following type of welding: (May/ June 2012)**

**(i) TIG welding process. (May/ June 2012)**

In TIG welding, the electric arc is produced between a non-consumable tungsten electrode and the work piece. There is an electrode holder in which the non-consumable tungsten electrode is fixed when the arc is produced.

By supplying the electric power between the electrode and the work piece, the inert gas from the cylinder passes through the nozzle of the welding head around the electrode. The inert gas surrounds the arc and protects the weld from atmospheric effects and defect free joints are made.

The process is also called as Gas Tungsten-arc welding (GTAW). Filler metal may or may not be used. When a filler metal is used, it is usually fed manually into the weld pool.



An electrode used in this process is tungsten. It has high melting point ( $3300^{\circ}\text{C}$ ), therefore, it will not be melted during weld. This process is used for welding steel, aluminium, cast iron, Magnesium, Stainless steel, Nickel based alloy, copper based alloys and low alloy steel. It is used for combining the dissimilar metals in hard facing and surfacing of metals. This process is used for the metals having thickness less than 6.5 mm.

### Advantages

1. No flux is required
2. High welding speed
3. It produces high quality weld
4. No weld cleaning is necessary

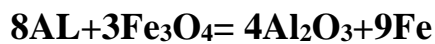
**11. What is the principle of thermit welding? Explain the same with a neat sketch of the welding arrangement. (May/ June 2012)(Nov/Dec-2018)**

### Principle of thermit welding

Welding the parts by using liquid thermit steel around the portions to be welded is called Thermit welding. Thermit welding is a fusion of welding process. In this process, neither arc is produced to heat parts nor flames are used. For getting the high temperature,

the exothermic reaction is used. Welding principle is the heat of the thermit reaction used for welding in plastic state and mechanical pressure is applied for the joint

It is depending on the chemical reaction between iron oxide and aluminium. The reaction in thermit welding is



This reaction takes place about 30 sec only and the heat liberation temperature is about  $2800^\circ\text{C}$ . It is twice the melting temperature of steel.

### Working :

Thermit is a mixture of aluminium and iron oxide in the ratio of 1:3. This is placed in a furnace and it ignited. So, the chemical reaction takes place. Due to this, liquid and slag are formed which are used for welding.

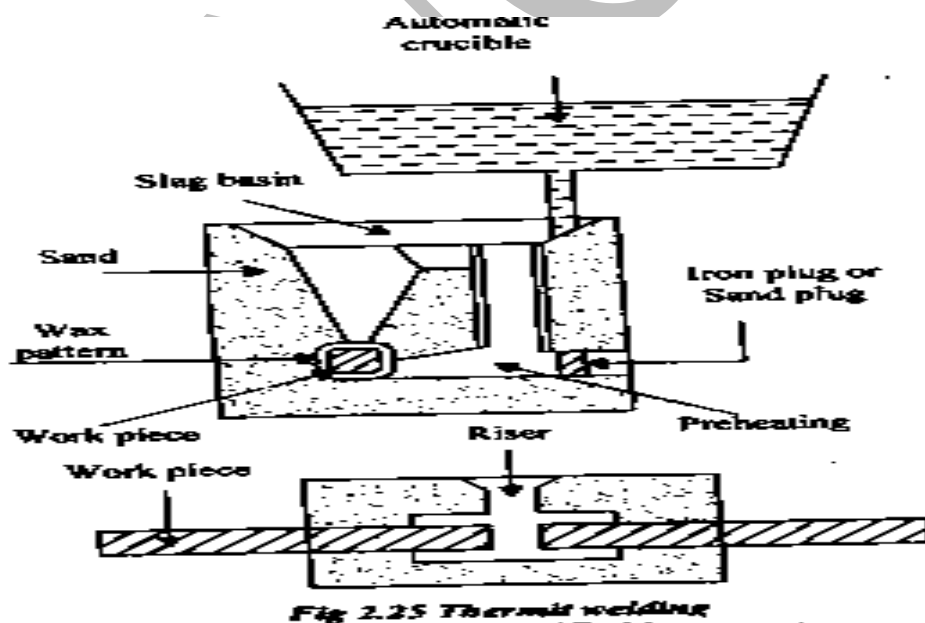


Fig 2.25 Thermit welding

The thermit welding process is classified into two types.

1. Pressure welding process
2. Non-pressure welding process

### 1. Pressure welding process

During the Pressure welding process, the part to be welded are butted and enclosed in a mould. The mould can be easily removed after the welding of metals.

First, the heated iron slag is poured to the mould and then the aluminium oxide is poured on the parts to be welded. This will create the heating of parts and then the pressure is applied on the work piece to join.

### 2. Non-pressure welding process

In this process, the part to welded are lined up in parallel and a groove is taken in the parts. The wax pattern is formed in and around the welding parts. Then sand is rammed around the wax pattern and mould is completed with gate, runner and raiser around the joint is made.

Then the mould is heated and wax is melted, it will give a space between the joint. Finally, the heated iron slag and aluminium are poured into the mould after solidification of liquid metal. Thus, the joint is made.

### Application

1. It is used in steel rolling mills.
2. It is used to weld non ferrous metals.
3. Pipes, Cables, Rails, Shafts are made in this process.
4. Automobile parts are welded by this process.

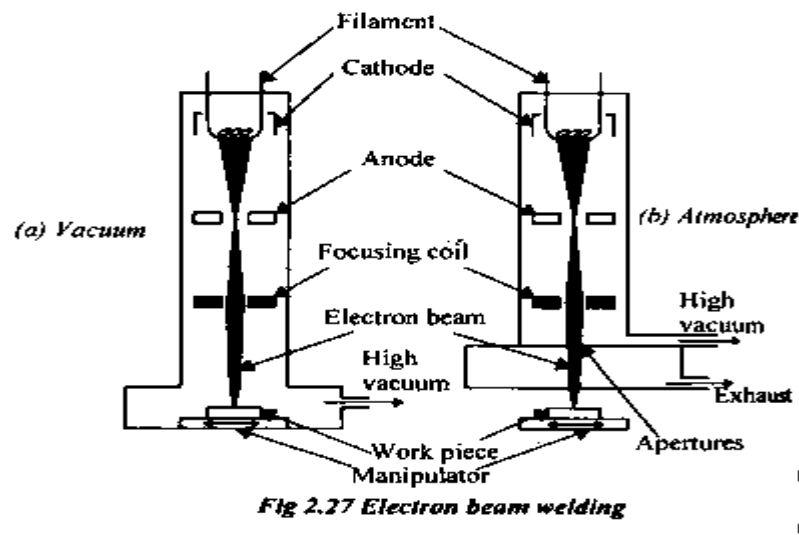
### 12. Explain the principle of operation, advantages and limitations of electron beam welding. Principle: (May/ June 2012)

Beam of electron is used for producing high temperatures and melting the work piece to be welded

**Working;**

When tungsten filament is electrically heated in vacuum, it will emit the electrons. These electrons carry a negative charge which is passed through the anode hole. The electron beam is focused by the focusing lens. When the focused electron beam strikes the work piece, the kinetic energy of this electron beam is converted into heat energy.

This heat energy is used to weld the metals. The operation is carried out in vacuum. So, it is possible to weld holes. The Beam are focused about 0.25 to 1 mm diameter and power density of  $10\text{kW}/\text{mm}^2$  aluminium material having focusing length of about 40 mm and sreeel about 30 mm.



The variables which are controlled in the electro beam welding are

1. voltage
2. Speed
3. Distance between beam gun to work piece

**Advantages**

1. High quality weld is produced
2. Deep welding is possible
3. Clean and bright weld can be obtained
4. High speed operation is achieved
5. Dimensional accuracy is good
6. Energy loss is very less.

**Disadvantages**

1. Cost is high
2. Skilled persons are required
3. It is limited to small size only
4. It is a time consuming process

**Applications**

1. Dissimilar metals can be welded
2. Refractory and reaching metals can be welded
3. It is used in air crafts
4. It is suitable for large scale
5. It is used in cams

**Thermit Welding (TW)**

FW process in which heat for coalescence is produced by superheated molten metal from the chemical reaction of thermite

Thermite = mixture of Al and  $Fe_3O_4$  fine powders that produce an exothermic reaction when ignited

Also used for incendiary bombs

Filler metal obtained from liquid metal

Process used for joining, but has more in common with casting than welding



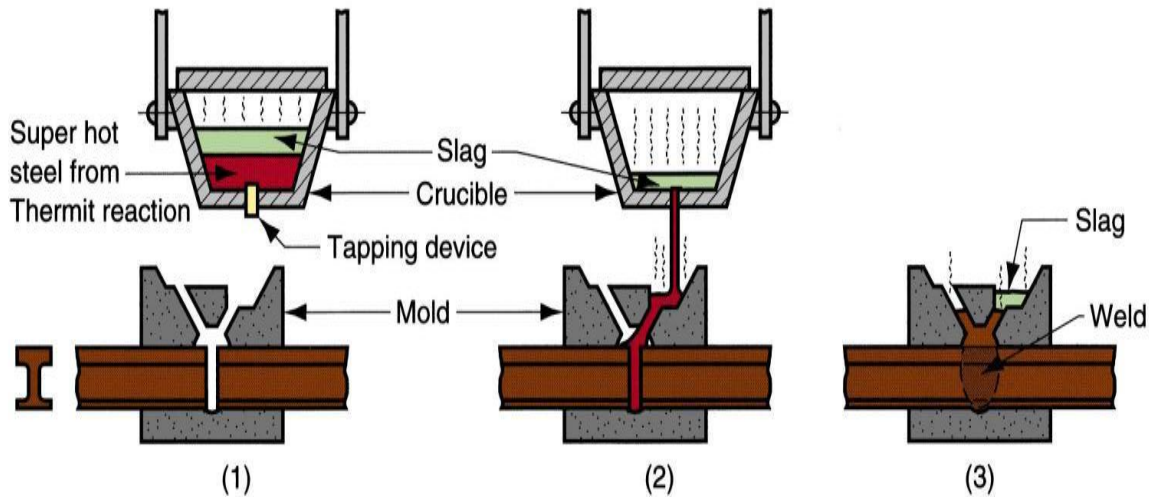


Fig: Thermit welding: (1) Thermit ignited; (2) crucible tapped, superheated metal flows into mold; (3) metal solidifies to produce weld joint.

### Applications

Joining of railroad rails

Repair of cracks in large steel castings and forgings

Weld surface is often smooth enough that no finishing is required

### Friction Welding (FRW)

SSW process in which coalescence is achieved by frictional heat combined with pressure

When properly carried out, no melting occurs at faying surfaces

No filler metal, flux, or shielding gases normally used

Process yields a narrow HAZ

Can be used to join dissimilar metals

Widely used commercial process, amenable to automation and mass production

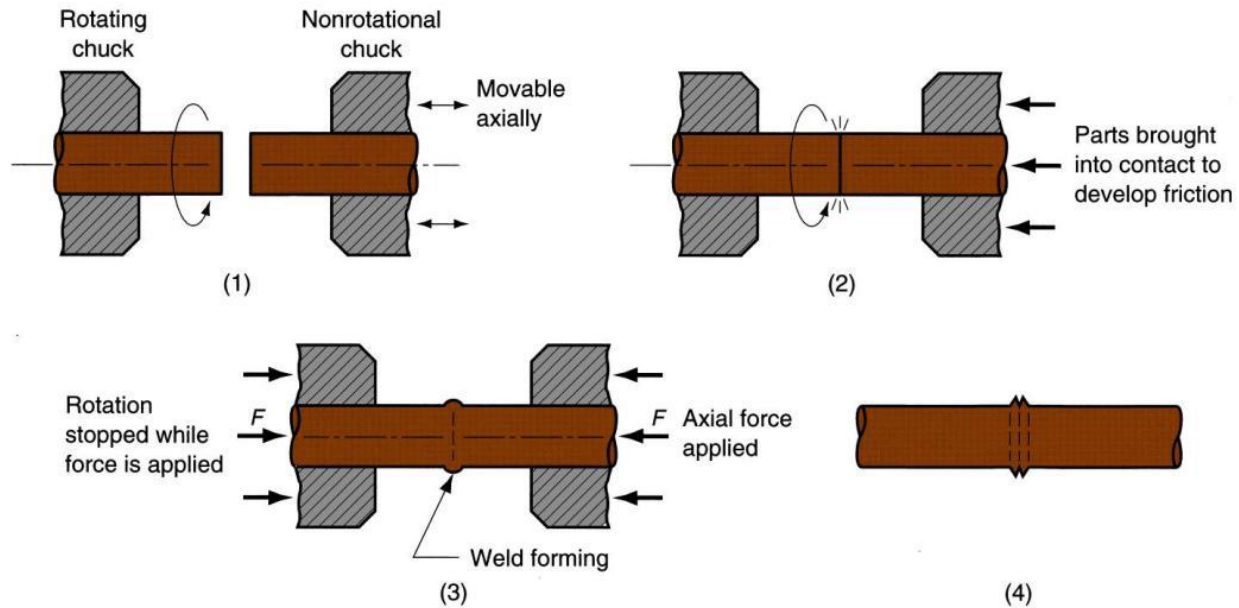


Fig:

Friction welding (FRW): (1) rotating part, no contact; (2) parts brought into contact to generate friction heat; (3) rotation stopped and axial pressure applied; and (4) weld created.

### Applications

Shafts and tubular parts

Industries: automotive, aircraft, farm equipment, petroleum and natural gas

### Limitations

At least one of the parts must be rotational

Flash must usually be removed

Upsetting reduces the part lengths (which must be taken into consideration in product design)

### Brazing

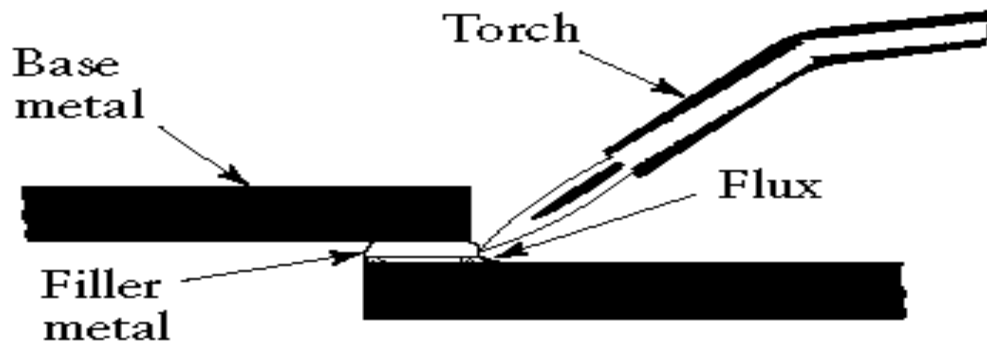
It is a low temperature joining process. It is performed at temperatures above  $840^{\circ}\text{F}$  and it generally affords strengths comparable to those of the metal which it joins. It is low temperature in that it is done below the melting point of the base metal. It is achieved by diffusion without fusion (melting) of the base

### Brazing can be classified as

Torch brazing

Dip brazing

Furnace brazing  
Induction brazing



### Advantages

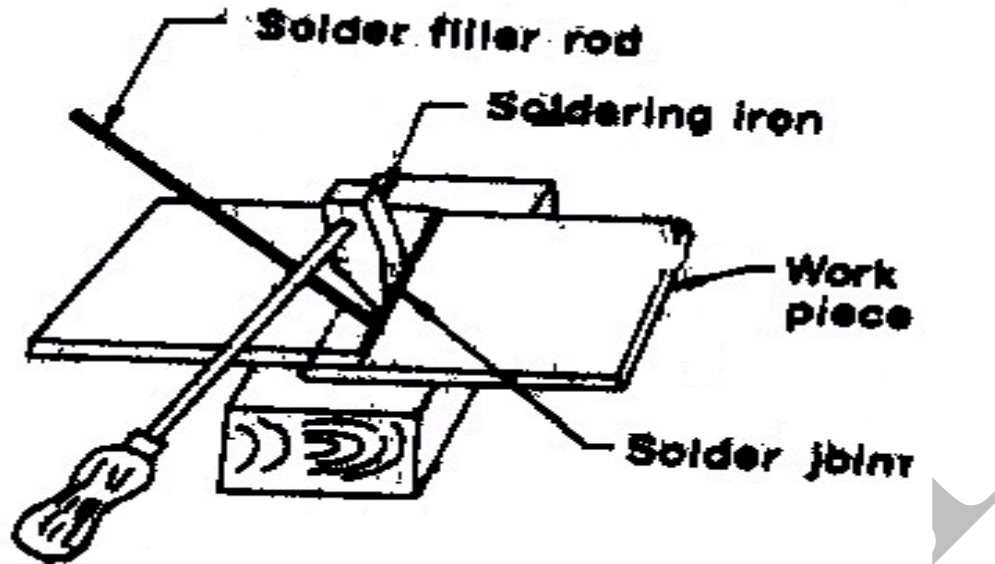
- Dissimilar metals which cannot be welded can be joined by brazing
- Very thin metals can be joined
- Metals with different thickness can be joined easily
- In brazing thermal stresses are not produced in the work piece. Hence there is no distortion
- Using this process, carbides tips are brazed on the steel tool holders

### Disadvantages

- Brazed joints have lesser strength compared to welding
- Joint preparation cost is more
- Can be used for thin sheet metal sections

### Soldering

- It is a low temperature joining process. It is performed at temperatures below 840°F for joining.
- Soldering is used for,
  - Sealing, as in automotive radiators or tin cans
  - Electrical Connections
  - Joining thermally sensitive components
- Joining dissimilar metals



### Weld Defects

- Undercuts/Overlaps
- Grain Growth

A wide T will exist between base metal and HAZ. Preheating and cooling methods will affect the brittleness of the metal in this region

- Blowholes

Are cavities caused by gas entrapment during the solidification of the weld puddle. Prevented by proper weld technique (even temperature and speed)

- Inclusions

Impurities or foreign substances which are forced into the weld puddle during the welding process. Has the same effect as a crack. Prevented by proper technique/cleanliness.

- Segregation

Condition where some regions of the metal are enriched with an alloy ingredient and others aren't. Can be prevented by proper heat treatment and cooling.

- Porosity

The formation of tiny pinholes generated by atmospheric contamination.

Prevented by keeping a protective shield over the molten weld puddle.

**13. Sketch the different types of weld defects and mention how they occur [AU-NOV/DEC-2012]**

The improper welding parameters, the base metal and selection of method introduce defects in the weld metal. So the defective weld causes failure in service conditions and damage to the properties the defects in weld depending on thickness, load, environment and size of the weld. The major defects which are causing in the weld are

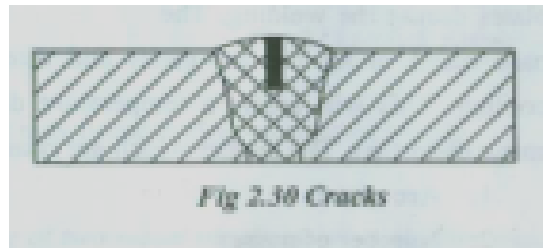
1. Incomplete fusion
2. Cracks
3. Porosity
4. Under cut
5. Distortion
6. Slag inclusion
7. Lamellar tearing
8. Overlapping

**1. Incomplete fusion**



This is due to improper penetration of the joint. The parameter mainly affects the welding current. If the current is very low it is not sufficient to heat the metal all over the place. The wrong design of the weld also causes defect

## 2. Cracks



The cracks are mainly classified into two types

1. Hot cracking
2. Cold Cracking

Hot cracking occurs at high temperature. Cold cracking occurs at room temperature. The main causes of crack formation are

1. Arc speed
2. Ductility
3. Solidification rate
4. Temperature

## 3. Porosity



It is due to presence of gases in the solidifying metal which are producing porosity. The gases are oxygen, nitrogen and hydrogen. The parameters which are causing porosity are

1. Arc speed
2. Coating of the electrodes

3. Incorrect welding technique
4. Base metal composition

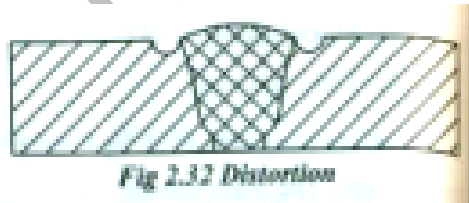
The sources of hydrogen formed on the weld pool are electrode coatings. Then the oxygen becomes oxide form in the pool. Nitrogen enters in the form of atmospheric nitrogen.

#### 4. Undercut

Groove gets formed in the parent metal along the sides of the weld. The main causes of the undercut are

1. High current
2. Arc length
3. Electro diameter
4. Inclination of electrode

#### 5. Distortion



It is defined as the change in shape and difference between the positions of two plates during the welding. The base metal under the arc melts and already welded base metal starts cooling. This will create a temperature difference in the weld and will cause distortion. The factors which are causing distortion are

1. Arc speed
2. Number of passes
3. Stresses in plates

4. Joint types
5. Order of welding

### 6. Slag inclusion



Fig 2.33 Slag inclusions

During the solidification of weld, any foreign materials present in the molten metal will not float. It will entrap inside the metal. So, this will lower the strength of the joint.

### 7. Lamellar tearing

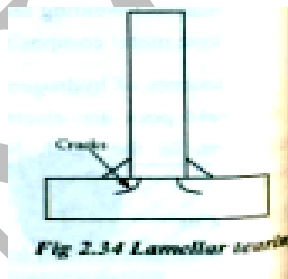


Fig 2.34 Lamellar tearing

This is due to presence of non metallic inclusions. It is formed during the non metallic inclusions, running parallel to the plates. It is seen in large structures. The T type and corner joints are getting in this type of cracks.

### 8. Overlapping

It occurs when a molten metal flows over the parent metal and remains without fusing. The parameters which are causing overlapper.

1. Arc length
2. Arc speed



3. Joint type

4. Current

Some of the welding defects may occur during we idle of metal.

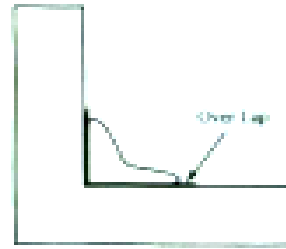


Fig 2.15 Over Lapping

**14. Explain any four major ways to control the output of arc welding transformer. (May/ June 2013)**

### Welding transformers

Figure 1.59 shows a schematic diagram of a welding transformer having thin primary windings with a large number of turns. On the other hand, the secondary has more area of cross-section and less number of turns ensuring less voltage and very high current in the secondary. One end of the secondary is connected to the welding electrode, whereas the other end is connected to the pieces to be welded.

If any high current flows, heat is produced due to the contact resistance between the electrode and the pieces to be welded. The generated heat melts a tip of the electrode and the gap between the two pieces is filled.

The winding used for the welding transformer is highly reactive. Otherwise, a separate reactor may be added in series with the secondary winding.

Figure 1.60 shows the volt-ampere characteristic of a welding transformer.

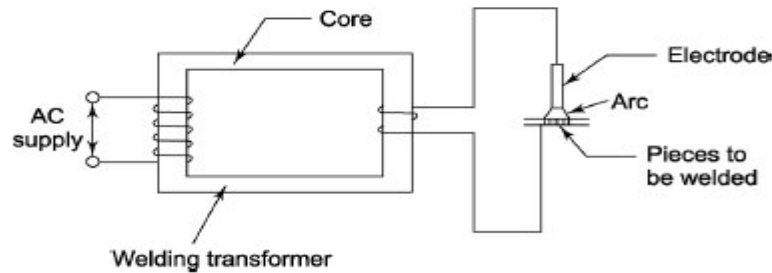


Figure 1.59 Welding Transformer

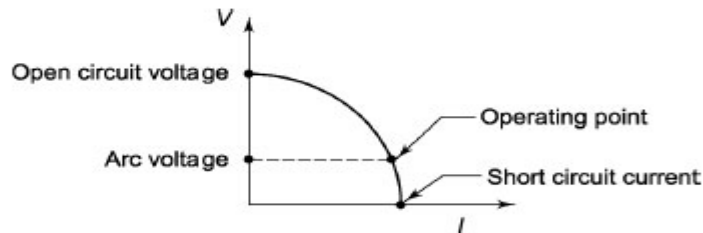


Figure 1.60 Volt-ampere Characteristic of a Welding Transformer

The winding used for the welding transformer is highly reactive. Otherwise, a separate reactor may be added in series with the secondary winding.

Figure 1.60 shows the volt-ampere characteristic of a welding transformer.

**15. To control the arc, various reactors are used with welding transformers. Some methods to control the arc are given below:**

### 1. Tapped reactor:

With the help of taps on the reactor, the output current is regulated. This has limit number of current settings shown in Figure 1.61

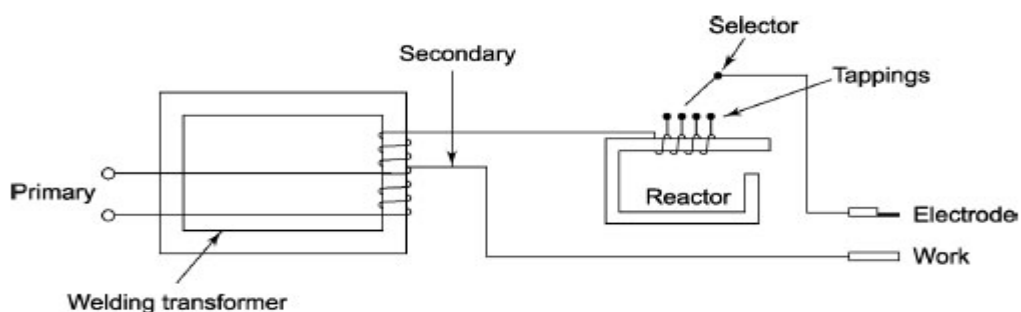


Figure 1.61 Tapped Reactor

## 2. Moving coil reactor:

Figure 1.62 shows a moving coil reactor in which the reactive distance between primary and secondary is adjusted. The current becomes less if the distance between the coils is large.

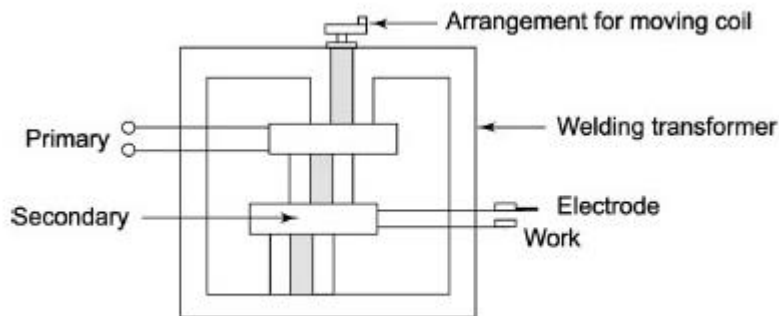


Figure 1.62 Moving Coil Reactor

## 3. Moving shunt reactor:

Figure 1.63 shows a moving shunt reactor in which the position of the central magnetic shunt can be adjusted. Change of the output current is obtained due to the adjustment of the shunted flux

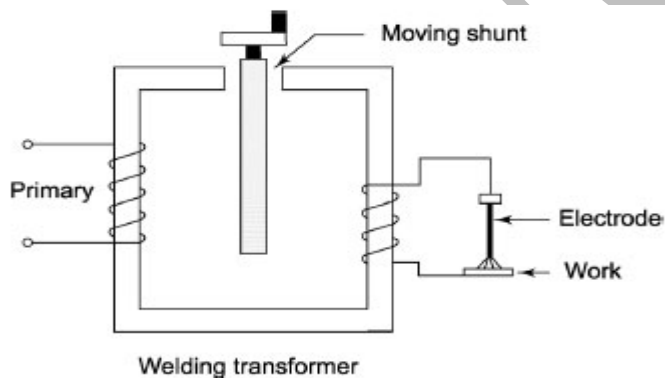


Figure 1.63 Moving Shunt Reactor

## 4. Continuously variable reactor:

Figure 1.64 shows a continuously variable reactor in which the height of the reactor is continuously varied. Greater reactance is obtained due to greater core insertion and hence the output current is less.

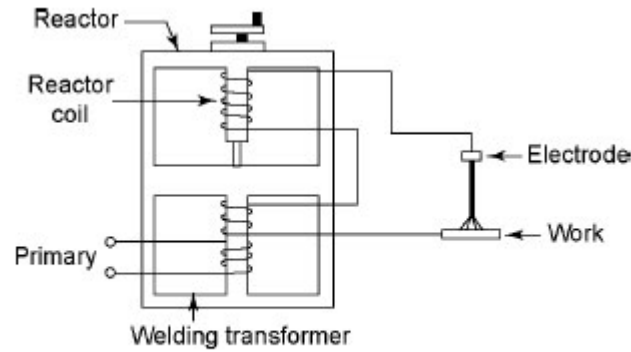


Figure 1.64 Continuously Variable Reactor

**16. Explain the three variables involved in continuous drive friction welding. (May/June 2013)**

The variable parameters of the friction welding process are as follows:

1. Speed (only when DC drive is used)
2. Pressure
3. Loss of length (or time)

Let's now take a look at these parameters one at a time:

**1. Speed**

The function of the rotational speed is to produce a relative speed at the periphery of the components in excess of 250 Surface feet per minute (SFM) (for steels). This empirical figure is the same for solids and tubular components. Speeds below 250 Surface feet per minute (SFM) produce very high torques in the material (for a set pressure), and have a tendency to tear the metal fibers. There is no real limit as to the highest speed. Welds have been made up to 2000 SFM. However, in production welding machines, the SFM is usually arranged to be within 300-650 SFM. As an example, a machine spindle speed of 600 RPM will comfortably weld steel products of 2" dia. to 4" dia. (in fact larger than 4" dia.). The formula for calculating SFM is as follows:

$$\text{Surface feet per minute (SFM)} = \text{Spindle RPM} \times \text{Component dia. in feet}$$

While high rotational speeds can be used, they do not increase the speed of welding. Very high speeds ultimately lead the machine designer to use specialized bearing arrangements, which can be a source of maintenance problems. From a weld quality standpoint, speed is generally the least important parameter.

## 2. Pressure

There is a wide range of pressures that might be applied (for steels) to obtain a sound weld. However, it is recommended that the heating pressure is 4 tons per sq. in. of the component cross sectional area, and the forge pressure is 10 tons per sq. inch. These pressures can be varied if required to produce specific changes in physical properties, e.g. tensile, torsion, ductility, fatigue life, impact, etc. (one relative to the other).

In order to calculate the machine settings for pressure, one needs to know the area of the hydraulic cylinder and the area of the component to be welded. It is then possible to calculate the PSI gauge setting for the machine. Tables for these settings for various diameters are supplied with production machines.

The formula for calculating the PSI gauge setting is as follows:

$$\text{PSI Gauge} = \frac{\text{Tons/sq. in on component} \times \text{component area (sq. ins.)}}{2000 \times \text{cylinder area (sq. ins.)}}$$

As previously mentioned, it is possible if required to modify the pressure input during the heating phase. This can be done to produce "back heat" or pre-heat into the components, to achieve a relatively slower quench rate. If this is required, a pressure of 1.5 tons per sq. in. of component area is applied before the heating pressure.

## 3. Loss of Length (or Time)

A fundamental requirement of a solid-phase weld is that at least a minimum amount of the original component surfaces are removed within a certain period of time in order to

bring together clean parent materials at the forging phase. The simplest means to achieve this situation is to apply the heating phase for a pre-set time.

In practice, however, because no two surfaces of engineering parts are truly identical (grease, forging shape, forging scale, saw cut, paint, dirt, etc.), it is better, from a quality standpoint, to control the friction welding process on the length loss between the components. This method provides assurance that some of the welding cycle time has not been used in overcoming differing component surface conditions. For example, because one set of components has greater saw cut angle on their surfaces than normal, two seconds of a six second weld cycle can be used to remove this condition before getting into the heating phase proper on the full area.

**17. What are the nondestructive tests used in welding inspection? Explain any one method. (May/ June 2013)**

#### **Nondestructive testing (NDT)**

Non-destructive testing (NDT) is a wide group of analysis techniques used in science and industry to evaluate the properties of a material, component or system without causing damage.

The terms **Nondestructive examination (NDE)**, **Nondestructive inspection (NDI)**, and **Nondestructive evaluation (NDE)** are also commonly used to describe this technology. Because NDT does not permanently alter the article being inspected, it is a highly valuable technique that can save both money and time in product evaluation, troubleshooting, and research

Nondestructive testing is also known as nondestructive examinations or evaluation (NDE) or inspection.

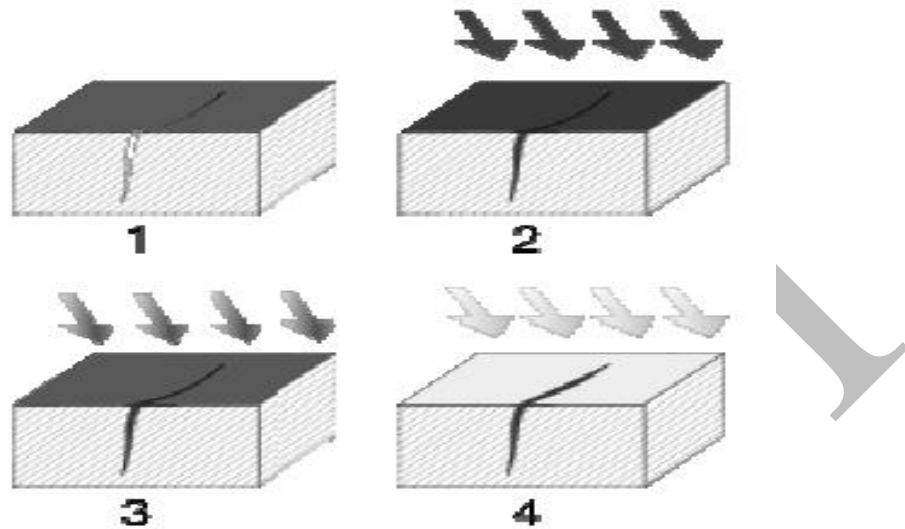
- These techniques use the application of physical principles from the detection of flaws or discontinuities in materials without impairing their usefulness.
- In the field of welding, four nondestructive tests are widely used:
  1. Dye-penetrant testing and Fluorescent-penetrant testing
  2. Magnetic particle testing
  3. Ultrasonic testing
  4. Radiographic testing

### **Weld Penetrant examination**

Liquid-penetrant examination is a highly sensitive, nondestructive method for detecting minute discontinuities (flaws) such as cracks, pores, and porosity, which are open to the surface of the material being inspected.

- It may be applied to many materials, ferrous and nonferrous metals, glass and plastics.
- The applied surface must be cleaned from dirt and film. So, discontinuities must be free from dirt, rust, grease, or paint to enable the penetrant to enter the surface opening.
- A liquid penetrant is applied to the surface of the part to be inspected. The penetrant remains on the surface and seeps into any surface opening. The penetrant is drawn into the surface opening by capillary action. The parts may be in any position when tested. After sufficient penetration time elapsed, the surface is cleaned and excess penetrant is removed.

- The penetrant is usually a red color; therefore, the indication shows up brilliantly against the white background. Even small defects may be located.



- Section of material with a surface-breaking crack that is not visible to the naked eye.
- Penetrant is applied to the surface.
- Excess penetrant is removed.
- Developer is applied, rendering the crack visible

### Applications:

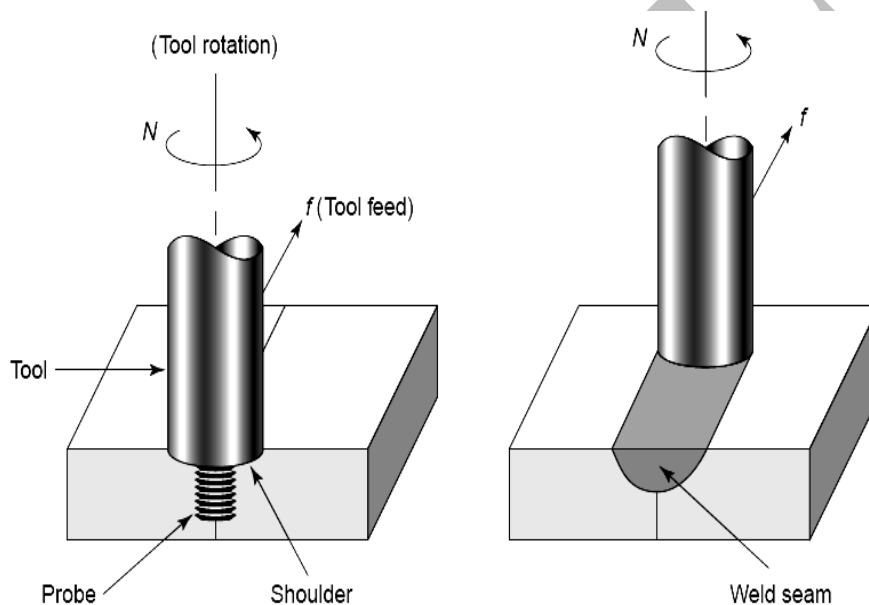
- Liquid-penetrant examination is used to detect surface defects in aluminium, magnesium, and stainless steel weldments when the magnetic particle examination method cannot be used.
- It is very useful for locating leaks in all types of welds. Welds in pressure and storage vessels and in piping for the petroleum industry are examined for surface cracks and for porosity.

### Fluorescent--Penetrant Examination:

- The penetrant is fluorescent and when it is exposed to ultraviolet or black light it shows a glowing fluorescent type of read-out.



- It provides a greater contrast than the visible dye penetrants.
- Used for leak detection in magnetic and nonmagnetic weldments.
- A fluorescent penetrant is applied to one side of the joint and a portable ultraviolet light is then used on the reverse side of the joint to examine the weld for leaks.
- Inspect the root pass of highly critical pipe welds.



**Fig: Friction stir welding**

**18. Explain the principle of arc welding. What are the different weld positions in arc welding? Enumerate some defects due to arc welding? (May/June 2014)**

In arc welding process, the heat is developed by an electric arc. The arc is produced between an electrode and the work. Arc welding is the process of joining two metal pieces by melting their edges by an electric arc. In arc welding, the electrical energy is converted into heat energy. The electrode and work piece are brought nearer with a small air gap of 3 mm approximately. Then the current is passed through the work piece and the electrode to produce an electric arc.

The work piece is melted by the arc, the electrode is also melted and hence both the work pieces become a single piece without applying any external pressure. The temperature of arc is about  $5000^{\circ}$  to  $6000^{\circ}\text{C}$ . The electrode supplied additional filler metal

into the joints and is deposited along the joint. A transformer or generator is used for supplying the current. The depth to which the metal is melted and deposited is called depth of fusion. To obtain better depth of fusion, the electrode is kept at  $70^\circ$  inclination to the vertical.

Electrodes used in arc welding are generally coated with a flux. The flux is used to prevent the reaction of the molten metal with atmospheric air. Also it removes the impurities from the molten metal and forms a slag. This slag gets deposited over the weld metal. This slag protects the weld seam from rapid cooling.

The molten metal is forced out of the pool by the electric arc. Hence a small depression is formed in the parent metal where the molten metal is piled up. This is known as “arc crater”. The distance between the tip of the electrode and the bottom of the arc crater is called “arc length”.

**UNIT-3**  
**METAL FORMING PROCESS**

**Two marks:-**

**1. What is meant by recrystallization temperature?(APRIL/MAY-2010)(Nov/Dec-2018)(Apl/May-2019)**

The recrystallization temperature is defined as the minimum temperature at which the complete recrystallization of a metal takes place within a specified time.

**2. List out any four parts that can be manufactured by shape rolling operations.[APRIL/MAY-2010]**

- Straight and long structural shapes.
- Solid bars
- I-beams
- Channels
- Railroad rails

**3. Define extrusion ratio.[NOV/DEC-2011]**

It is defined as the ratio of the cross sectional area of the billet to the cross section area of the product.

**4. Distinguish between hot working and cold working of metals. (MAY/JUNE 2012)**

Sl.No	Hot working	Cold working
1.	Working above recrystallization Temperature	below recrystallization temperature
2.	New crystal are formed after hot working	No recrystallization
3.	Harden the metal	No hardening
4.	Elongation of metal take place	Elongation decreases
5.	Surface finish is not good	Good surface finish can be obtained

**5. Define extrusion, as a manufacturing process. (MAY/JUNE 2012) (NOV/DEC 2009)**

The heated metal is compressed and forced through a suitable shaped die. The force required for the cold extraction process is high. So, most of the metals are extruded in hot conditions only

**6. List two advantages of hot extrusion over cold extrusion.[NOV/DEC-2012]**

- Higher strength due to cold working
- Good mechanical properties that are provided the temperatures created, are below the recrystallization temperature
- Closer tolerances
- Good surface finish
- Fast extrusion speeds, in case the material is subjected to hot shortness  
Dimensional precision
- Lower energy consumption
- Higher production rates

**7. Define cold working of metals.**

Those processes, which are working below the recrystallization temperature, are called cold working of metals.

**8. Define recrystallization temperature.**

The approximate minimum temperature at which complete recrystallization of cold- worked metals takes place within a specified time is as recrystallization temperature.

**9. Give some examples for mechanical working of metals.**

Rolling  
Drawing  
Forging  
Extrusion  
Press working

**10. Define the process of mechanical working metals**

Mechanical working processes are based on permanent changes in the shape of body due some external forces.

**11. Define hot working of metal.**

Those processes which are working above the recrystallization temperature are called hot working of metal.

**12. What are the advantages of hot working over cold working?**

Hot working requires less force to get necessary deformation

Brittle materials can also be hot worked.

**13. What are the advantages of cold working over hot working?**

Good surface finish.

Better dimensional accuracy.

**14. Give the classification of rolling mills.**

Two high rolling mill

Three high rolling mill

Four high rolling mill

Multi high rolling mill

Universal high rolling mill

**15. What are two common methods of thread rolling?**

Using fixed and movable flat dies.

Using two or three roller type dies.

**16. What are the advantages of cold rolling?**

Improve mach inability

Improve physical properties

Good surface finish and high accuracy.

**17. Define forging.**

Mechanical working of metals by which metals and alloys are plastically deformed by the application of compressive force is known as forging process.

**18. Define open – die forging.**

Open-die forging also called hammer forging or flat-die forging. In this process, the work – piece is hammered between two flat surfaces.

**19. Define closed die forging.**

In closed die forging, the impressions are cut in the die block and the metal is forced into it to get the final shape.

**20. Give some basic forging operations.**

Upsetting	filtering
-----------	-----------

Drawing	cast off
---------	----------

Bending	heading
---------	---------

**21. Define press forging.**

The press forging is a process in which the metal is plastically deformed by squeezing action to get the required shape.

**22. Give some hand tools, which are used in the forging operations.**

Swage block	fillers
-------------	---------

Hammers	flatters
---------	----------

Tongs	punch
-------	-------

Chisels	swage
---------	-------

**23. Define upsetting.**

Upsetting is a process of increasing the thickness of a bar at the expense of its length.

**24. What are the types of force welds?**

Lap weld  
Butt weld  
T or Jump weld  
V finished weld

**25. Define extrusion ratio.**

It is defined as the ration of the cross sectional area of the billet to the cross sectional area of the product.

**26. What is wire drawing?**

Drawing of metal through a small aperture and wound in the form of coil is called wire drawing. The aperture is generally below 16mm diameter.

**27. Define tube drawing.AU(NOV/DEC 2010)**

Making hollow cylinder and tubes by hot working processes like extrusion, piercing is called tube drawing.

**28. What are the classifications of tube drawing process?**

Tube sinking  
Tube drawing with a plug  
Tube drawing with a moving mandrel.

**29. What are the types of hammers used in forging operations?**

Single acting hammer  
Double acting hammer  
Pneumatic hammer  
Steam hammer

**30. What is the formula used for finding clearance in the die opening?**

$$C=0.0032 t \sqrt{\tau_s} \text{ mm}$$

Where  $\sqrt{\tau_s}$  in N/mm<sup>2</sup>

**31. What is the formula used for finding out maximum force required to cut a material?**

$$F_{\max} = \pi D t \tau_s = p.t.\tau_s - \text{for circular blank}$$

Where, P- Perimeter

$$F_{\max} = 2(L+b) t \tau_s$$

L – Blank – length b – width.

**32. What is the formula for work done to make a cut?**

Work done,

$$E = F_{\max} \times \text{punch travel}$$

$$= F_{\max} \times k \times t.$$

Where, k – percentage of penetration

If energy loss accounted

$E = F_{\max} \times k \times t \times c$  Where, C – amount of extra energy required.

**33. Define slab, plate, sheet and strip.**

Slab – obtained from bloom by rolling

Plate – the thickness, which is having minimum 6.35mm

Sheet – thin part her of plate.

Strip – a narrow sheet having maximum width of 600mm

**34. What is the formula used for calculating roll force?**

Roll force,  $F = L_w Y_{\text{avg}}$

Where,

L = Roll strip contact length

W = width of the strip

$Y_{\text{avg}}$  = average true stress.

**35. What is the formula used for power per roll?**

$$\text{Power} = \frac{2\pi KLN}{6000}$$

Where, F = force in Newton's.

N = speed of the roll in rpm.

**36. What is the formula used for roll strip contact length?**

$$L = \sqrt{R(h_o - h_f)}$$

Where,  $h_o - h_f$  = difference between initial and final thickness.

R = roll radius.

**37. What is meant by recrystallisation temperature? What is its effect?**

The recrystallisation temperature is defined as “the approximate minimum temperature at which the complete recrystallisation of a cold worked metal occurs within a specified period. Recrystallisation decreases the strength and raises the ductility of the metal.

**38. Distinguish between direct and indirect extrusion. What are advantages?(Nov/Dec-2018)**

Direct extrusion	Indirect extrusion
1. In the metal is squeeze through the die in the direction of the applied force. 2. Solid ram is used	1. In the metal squeeze through the die in the direction opposite in the applied force. 2. Hollow ram is used.

**Advantage:** indirect extrusion requires less force compared to direct extrusion.

**39. In a four-high rolling mill, small diameter rolls as working rolls why?**

The small diameters of the working rools reduce the roll separating force and power requirements.

Since small diameter rolls to be selected as working rolls.

We can also avoid the bending of work- Toll by choosing smaller diameter as a working roll and larger diameter as back – up roll.

**40. Which extrusion process requires more force? Why?**

Cold extrusion requires more force than hot extrusion.

The cold extrusion is done below the recrystallization temperature.

**41. Classify the types of forging.**

The forging processes may be classified as follows.

1. Smith forging or open die forging or hand is forging.
  - b) Power forging
    - Hammer forging
    - power forging
2. closed die or impression forging
  - a. drop forging
  - b. press forging
  - c. upset forging
3. Roll forging

**42. state the defects in rolled parts**

Defects in rolled parts:

1. Surface defects:
  - It includes scale, rust scratches, cracks and pits.
2. Internal structural defects
  - in includes wavy edges, zipper cracks, edge cracks, folds alligating and laminations.
3. Other defects in rolling
  - in homogenous deformation of elements across the width.
  - in homogenous deformation in the thickness section.
  - folds
  - lamination.

**43. what are the general advantages of forging as a manufacturing process?**

General advantages :

- Forgings are free from gas and shrinkage porosities
- Production rate is high
- Many materials and alloys can be used for producing components.
- Mechanical properties of components are better.
- The process is economical and utilizes optimum amounts of materials.

**44. List various operations generally performed in a sheet metal shop.**



- Blanking
- Punching
- Piercing
- Drawing
- Ironing
- Bending
- Forming
- Spinning

**45. What are advantages of cold forming?**

- axis symmetric components and fasteners are produced.
- tool setting time is greatly reduced.
- required shapes are easily made.
- there is no thinning of work material
- on long parts are made by forming process.

**46. what is meant by nibbling?**

it is the process of cutting specific contours on sheet metal by using small punch repeatedly along the necessary contours to get required profile.

**47. what are the limitations of explosive forming?**

- explosive forming is noisy in operation.
- there is possible to explosive accident.
- die erosion is a big problem.
- greater halyard of die failure due to high pressure generated.

**48. Differentiate extraction and forging. (Nov/Dec 2013)**

Sl.no	Extrusion	Forging
1.	Extrusion may be defined as the manufacturing process in which a block of metal enclosed in a container is forced to flow through the opening of a die.	Forging may be defined as a metal working process by which metals alloy and are plastically deformed to the desired shape by application of a compressive force.
2.	Extrusion is more widely used in manufacture of solid and hollow sections from non-ferrous metals and their alloys.	Forging may be done either hot and cold. However , forging is always understood to be hot working, unless stated other wise.

**49. What is difference between hot and cold forging. (Nov/Dec 2013)**

<b>Sl.No</b>	<b>Hot forging</b>	<b>Cold forging</b>
1.	Hot working to: high carbon steel, high alloy steels metals such as stainless steel, carbide steel, etc.	Limited formability limits the use of cold working to: low and medium carbon steels (0.25 to 0.45 % C), low alloy steels, copper and light metals such as aluminium, magnesium, titanium and beryllium.
2.	Various cold forging techniques employed in forging practice are : drop, press and roll forging,etc.	Various cold forging techniques employed in forging practice are : sizing, coining and heading,etc.

**50. What do you mean by angle of bite. (Nov/Dec-2018)**

In rolling metals where all the force is transmitted through the rolls, maximum attainable angle between roll radius at the first contact and the roll centers. If the operating angle is less, it is called the contact angle or roll angle

## FUNDAMENTALS OF METAL FORMING

There are four basic production processes for producing desired shape of a product. These are casting, machining, joining (welding, mechanical fasteners, epoxy, etc.), and deformation processes. Casting process exploit the fluidity of a metal in liquid state as it takes shape and solidifies in a mold. Machining processes provide desired shape with good accuracy and precision but tend to waste material in the generation of removed portions. Joining processes permit complex shapes to be constructed from simpler components and have a wide domain of applications.

Deformation processes exploit a remarkable property of metals, which is their ability to flow plastically in the solid state without deterioration of their properties. With the application of suitable pressures, the material is moved to obtain the desired shape with almost no wastage. The required pressures are generally high and the tools and equipment needed are quite expensive. Large production quantities are often necessary to justify the process.

To understand the forming of metal, it is important to know the structure of metals. Metals are crystalline in nature and consist of irregularly shaped grains of various sizes. Each grain is made up of atoms in an orderly arrangement, known as a lattice. The orientation of the atoms in a grain is uniform but differs in adjacent grains. When a force is applied to deform it or change its shape, a lot of changes occur in the grain structure. These include grain fragmentation, movement of atoms, and lattice distortion. Slip planes develop through the lattice structure at points where the atom bonds of attraction are the weakest and whole blocks of atoms are displaced. The orientation of atoms, however, does not change when slip occurs.

To deform the metal permanently, the stress must exceed the elastic limit. At room temperature, the metal is in a more rigid state than when at higher temperature. Thus, to deform the metal greater pressures are needed when it is in cold state than when in hot state.

When metal is formed in cold state, there is no recrystallization of grains and thus recovery from grain distortion or fragmentation does not take place. As grain deformation proceeds, greater resistance to this action results in increased hardness and strength. The metal is said to be strain hardened. There are several theories to explain this occurrence. In general, these refer to resistance build up in the grains by atomic dislocation, fragmentation, or lattice distortion, or a combination of the three phenomena.

The amount of deformation that a metal can undergo at room temperature depends on its ductility. The higher the ductility of a metal, the more the deformation it can undergo. Pure metals can withstand greater amount of deformation than metals having alloying elements, since alloying increases the tendency and rapidity of strain hardening. Metals having large grains are more ductile than those having smaller grains.

When metal is deformed in cold state, severe stresses known as *residual stresses* are set up in the material. These stresses are often undesirable, and to remove them the metal is

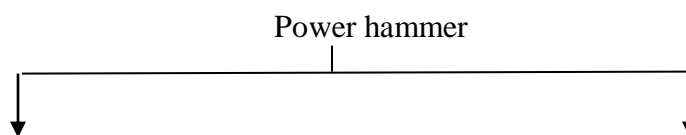
heated to some temperature below the recrystalline range temperature. In this temperature range, the stresses are rendered ineffective without appreciable change in physical properties or grain structure.

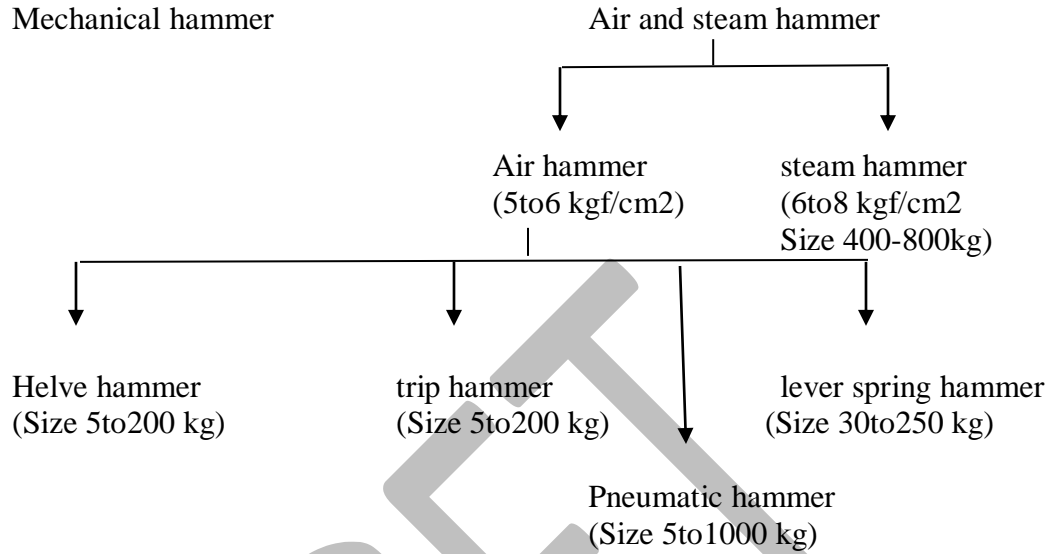
**1. Compare hot rolling and cold rolling**

hot rolling	cold rolling
<ol style="list-style-type: none"> <li>1. working above recrystalization temperature</li> <li>2. new crystal are formed after hot worked</li> <li>3. harden the metal</li> <li>4. impurities are removed from the metal</li> <li>5. elongation of metal takes place.</li> <li>6. large size metals also deformed</li> <li>7. surface finish is not good</li> <li>8. internal stress is not formed</li> <li>9. blowholes, cracks get welded during hot working</li> </ol>	<ol style="list-style-type: none"> <li>1. below recrystalization temperature</li> <li>2. no recrystalization</li> <li>3. no hardening</li> <li>4. impurities are not removed</li> <li>5. elongation decreases</li> <li>6. limited to size</li> <li>7. good surface finish can be obtained</li> <li>8. stress formation in the metal will occur</li> <li>9. ductility is obtained during cold working and it is useful for machining process</li> </ol>

**2. what are the types of power hammers available and explain the pneumatic hammer with a neat sketch  
or  
Classify the types of forging machines**

Types of power hammers the various types of hammers are used to perform forging operations they are



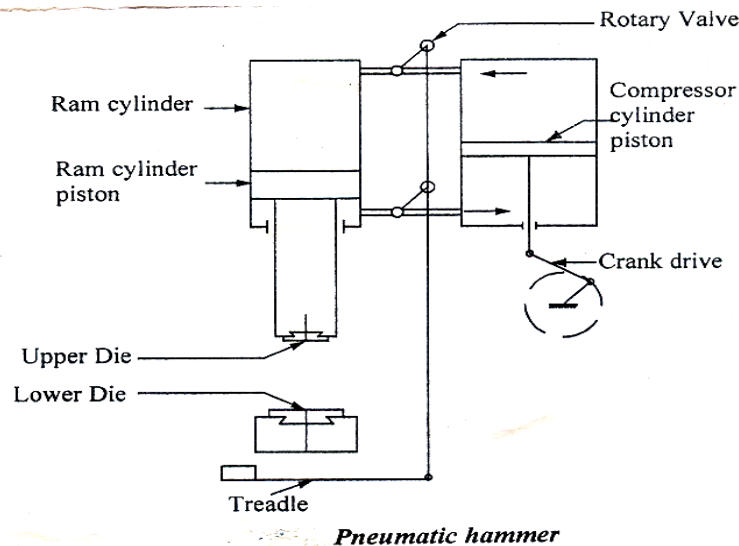


**Pneumatic hammer:**

The pneumatic hammers are having two cylinders.

1. Compressor cylinder
2. Ram cylinders

In these types of hammers, the compressor cylinder compresses the air and delivers it to the ram cylinder this compressed air pressure is used to actuate the ram cylinder piston. The blows range in the pneumatic hammer varies from 70 to 190 blows/min



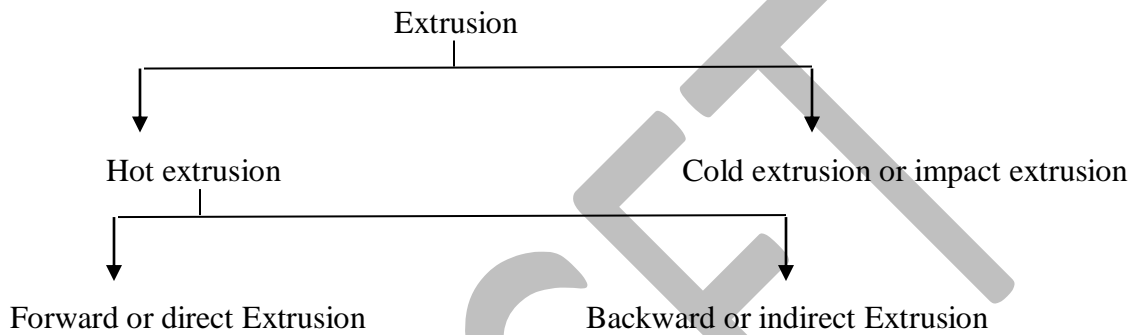
The weight the pneumatic hammer varies from 50 to 1000 kg. The compression of the reciprocating cylinder is obtained by crank drive and the crank is operated by a reduction gear

drive. The reduction gear drive is operated by motor.

The air distribution is made by rotary valves with ports, so, the air passes through the cylinder above and below the piston while operating the pneumatic hammers.

**3. Classify the extrusion processes and describe any two.**

**Types of extrusion**

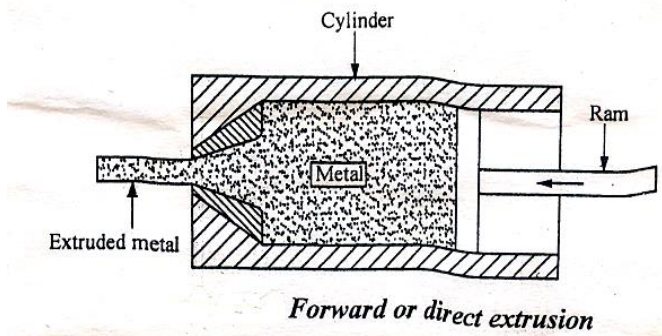


The hot extrusion process is classified into two types.

- Forward or direct extrusion
- Backward or indirect extrusion

**1. Forward or direct extrusion**

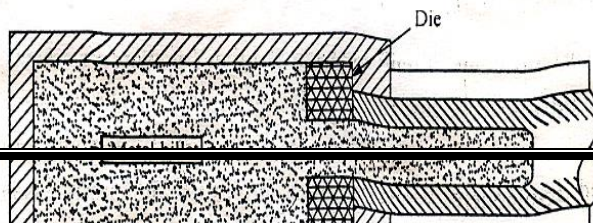
**Forward or direct extrusion**



- The forward or direct extrusion process is explained by using the above fig.
- Then the heated billet metal is placed in a press, which is operated by the ram and a cylinder.
- The heated metal billet is pushed by the ram and with the application of ram pressure the metal first plastically fills the die.
- Then it is forced act through the die opening and finally cut at the die face.

**2. Indirect or backward extrusion**

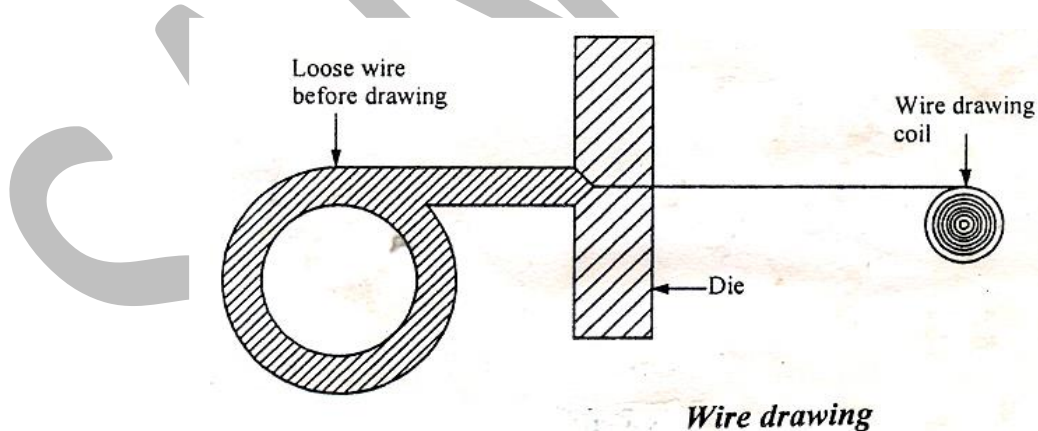
**Indirect or backward extrusion**



- In that extrusion process, the extruded part is forced through the hollow ram
- The ram is operated by horizontal hydraulic drive.
- Working principle of this process is that, the heated metal is placed in the die and the force is applied by the power operator hollow ram.
- The extracted metal is a pass through the hollow ram and it requires less force compared in the direct extrusion.

**4. With the aid of neat sketches explain the wire drawing process. Wire drawing process**

- The diameter less than 16mm has drawn in the force form of wire coil.
- Initially the point of the wire is sized so it is freely enter into the die.

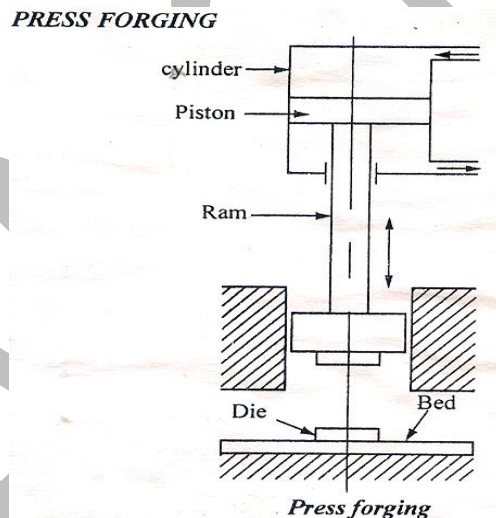


- This sized point coming out of the die orifice is fixed on the pliers or carriage. which pulls the rod through all the zones of die orifice.
- That will reduce the diameter of the rod.
- For making fine wire the rod is passed through the number of dies.
- Finally the wire is connected to the power reel to get the wire coil.

**5. Describe the followings.**

**(i) Press forging****(ii) Upset forging****Press forging**

- Press forging is done in a press. the press may be operated either mechanically or hydraulically.
- it is a closed die forging operations
- The action is relatively slow squeezing rater than delivering heavy blows.
- There is anvil to fix the lower die and upper die is fitted fix in the ram.
- The ram is allowed to move down slowly and presses the metal slowly with high pressure.
- The finished component may be automatically removed by providing ejectors in the die set.
- The capacity range from 50x10<sup>3</sup> to 80x10<sup>5</sup> kg and speeds vary from 34 to 40 strokes per minute.

**Applications**

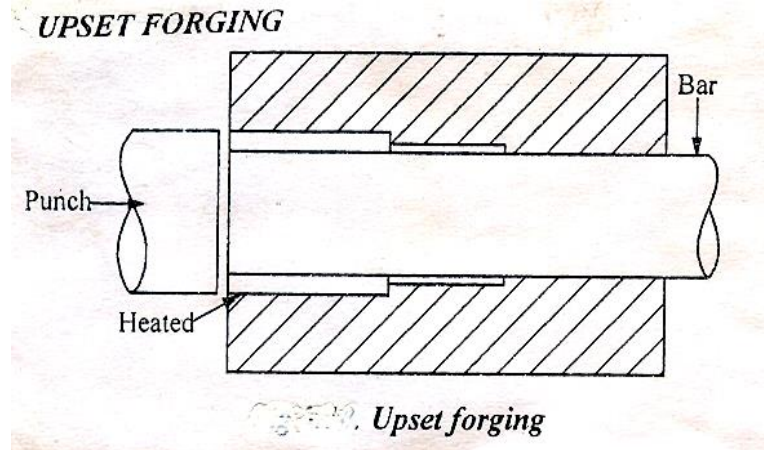
Press forging is used for making the parts.

1. spanner
2. connecting rod
3. machine components

**Upset forging**

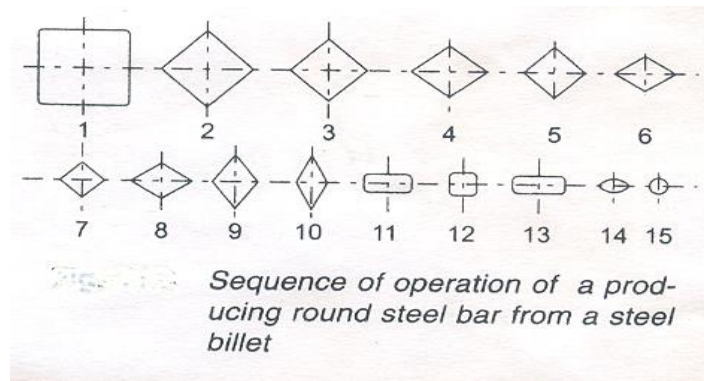
1. It is used to form head of bolt and rivet or pins.
2. The head may be square hexagonal or hemispherical.
3. The machine is having a die set.
4. The die set consists of a fixed die and movable punch.
5. The heated metal bar is held inside the solid die and force is given to the punch.
6. So, the punch will squeeze the heated metal to the shape of the die cavity.





**6. How round section are manufactured by rolling process. Explain the various sequence of operation.**

- A variety of sections can be produced by rolling.
- Some commonly produced shapes are shown in fig.
- It is important to mention here that desired shape of the rolled section is not achieved in a single pass.
- It has to be rolled again and again several times before the desired shape and cross-section is obtained.
- Thus the figure shows the sequence of rolling and number of passes required to reduce the cross-section of a billet to a round steel bar.



- In the process of rolling of ingots to bars, the ingots are first heated to the rolling temperature in soaking pits and then converted into blooms in blooming mills.
- Blooming mills a provided with mechanical manipulators to turn the hot ingots or billets through 90 after every pass.
- It enables all the surfaces of the ingots to come in contact with the rolls.

- Since the blooming mill is the first rolling mill through which the in got is passed it is also known as mother mill.
- After requisite number of passes, the metal is passed through grooved rolls to get the desired shape and size of cross-section.

**7. with the help of neat sketches, explain how a hexagonal nut can be manufactured from a cylindrical rod**

- The hexagonal nut can be manufactured by the extrusion process.
- Extrusion may be defined as manufacturing process in which a block of metal enclosed in a container is forced through the opening of a die.
- The hexagonal nut is manufactured either hot extrusion or cold extrusion process.
- The hot extrusion, first the billet is heated and then it is going to extrusion.
- In cold extrusion the cylindrical billet is introduce to extrusion without heating. Procedure for producing hexagonal nut.
- The hexagonal shaped cross-sectional die opening is provided at one end of the container.
- The ram with mandrel is fitted at the end of the container.
- The cylindrical billet is either heated or unheated depends upon the types of extrusion process will be choosed..
- Then it is placed in the die container.
- It is pushed by a ram with mandrel towards the die.
- The metal is subjected to plastics deformation slides along the walls of the container and is forced to flow through the die opening.
- Now, we obtain the axis symmetric hole with hexagonal shaped nut.

**Tapping:-**

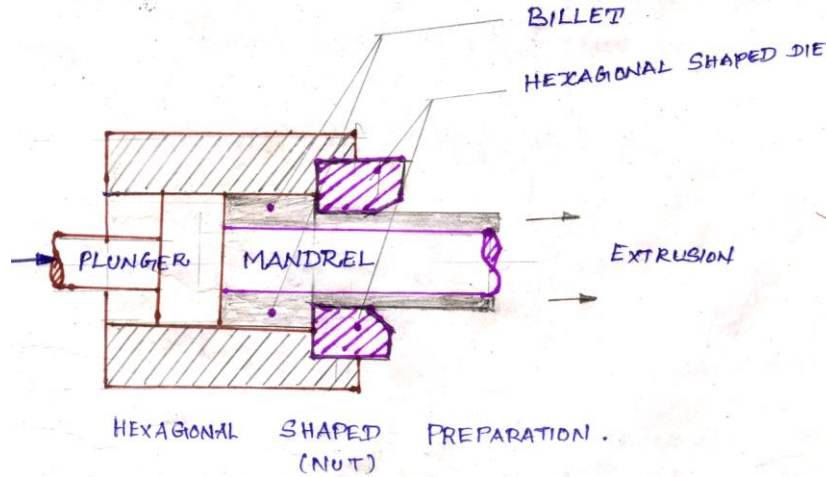
- The internal thread is obtained by the tapping operation with aid of tapping tool.
- Hexagonal nut is prepared by forging and swaging operation.

**Forging:-**

- The hexagonal nut is prepared from a cylindrical work piece by the following steps.
  1. The cylindrical work-piece is placed in between the upper and bottom dies. The power hammer is used to forging the work-piece.
  2. Similarly 60 is twisted the work piece and forged
  3. Finally also the work-piece twisted to 60 and forged.

**Swaging:-**

Swaging is the operation of reducing and finishing the work-piece obtain from forging operation.



**Tapping**

The internal thread is obtained by the tapping operation with aid of tapping tool.

**8.Distinguish between ‘Open-die forging’ and ‘Closed-die forging’[APR/MAY-2010;NOV/DEC-2011]**

S.NO	Open die Forging	Closed die Forging
1	The forging is done in a heated work at the work at the proper temperature by placing on flat surface of anvil through hammering the metal piece.	Impression dies called closed dies are used.The upper die is fitted on the ram and the lower die is fitted on the anvil.The metal piece is force between dies.
2	Hammering is done by giving repeated blows manually using hammer or by power hammer.	A single blow of press makes small and simple parts and large complicated shapes are made by number of steps.
3	This forging is very simple and flexible	This type of forging is complicated and rigid.
4	The pressure applied on metal piece is limited	Dies can be operated at maximum pressure without any limitations.
5	‘U’bolts,Chisels,Rectangular,Circular,hexagonal shape are made by open die forging process	Spanner,automobile parts and machine parts are made by closed die forging process.

**9.What are the defects in parts produced by rolling? Explain any four defects.[APR/MAY-2010, NOV/DEC 2013]**

There are two types of defects which can occur in rolled products.

1.Surface defects

2.Internal structural defects

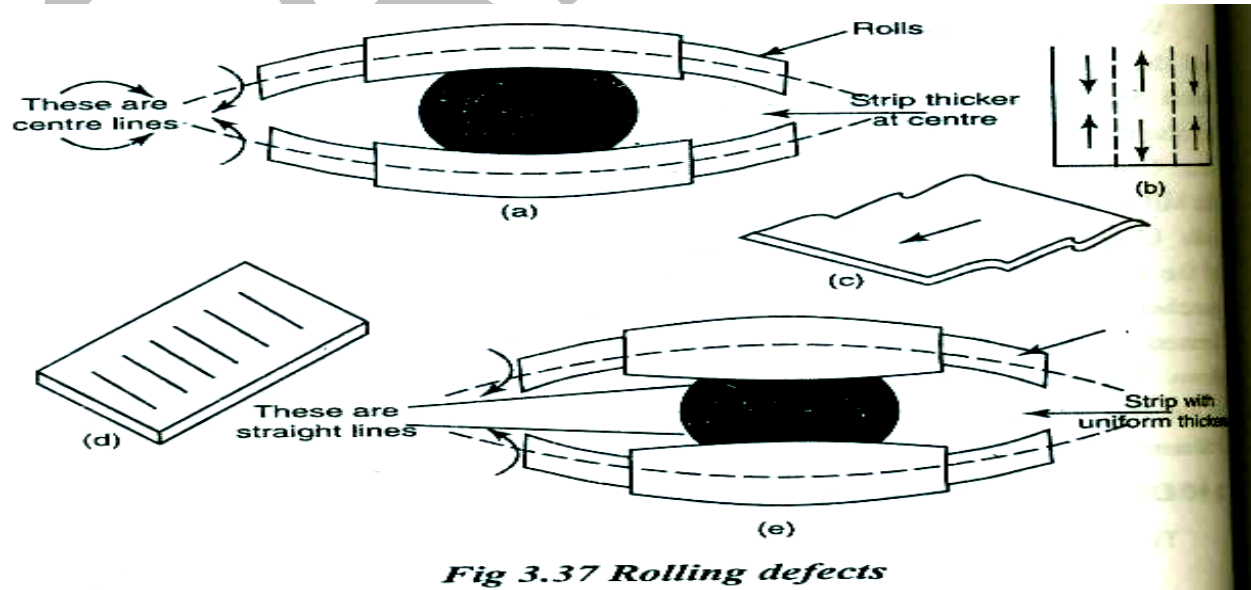
**1.Surface defects**

It includes scale,rust,scratches,cracks and pits.It is due to the impurities and inclusions in the original cast material.

**2.Internal structural defects**

It includes the following defects

- Wavy edges
- Zipper cracks
- Edge cracks
- Folds
- Alligatoring
- Laminations



**Fig 3.37 Rolling defects**

The defects wavy edges and Zipper cracks occurs due to bending of rolls. Normally the rolls act as straight beams. If the material flow is continuous and to maintain this continuity, strains within the material should adjust. There are compressive strain on the edges and tensile strain at the centre. Because of the edges are restrained from expanding freely in the longitudinal direction wavy edges on the sheet will be produced. The zipper cracks occur due to poor material ductility at the rolling temperature.

To avoid this camber to be provided to the rolls i.e diameter of rolls is made slightly larger at the centre than the edges.

### 3. What are all the Other defects in rolling

#### (i)In homogeneous deformation of elements across the width:

It is due to the decrease in thickness for the elements near the centre will be mainly converted into increase in length and near the edges the decrease in thickness is converted into lateral spread.

#### (ii)In homogeneous deformation in the thickness section:

It is due to in rolling the reduction in height is converted into increase in length and the thickness of the sheet does not undergo the same lateral deformation in the direction of rolling.

#### (iii)Folds:

It is created during plate rolling if the reduction per pass is very small.

#### (iv)Lamination:

Due to incomplete welding of pipe and blowholes during the rolling process the internal defects such as fissures are created.

### 10.Distinguish between wire drawing and tube drawing.[APR/MAY-2010]

S.NO	WIRE DRAWING	TUBE DRAWING
1	Wires are drawn without using a material.	Tubes are drawn with the use of plug or mandrels of required inside shape and size
2	In wire drawing,the number of passes is used to reduce the size of the wire	In tube drawing,Inside shape is formed in the first pass of metal through dies and the outside shape might be formed in the second pass or viceversa

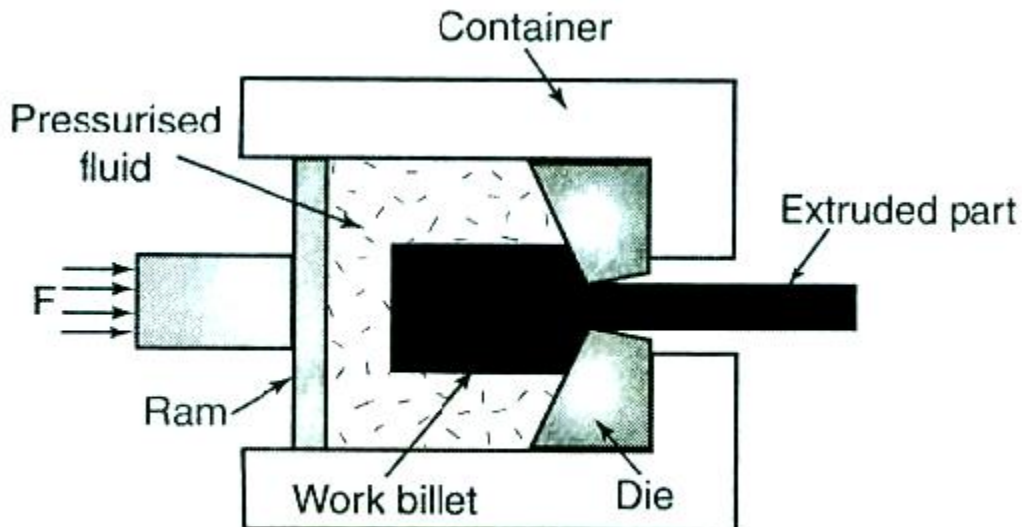
3	The diameter 16mm has drawn in the form of wire coil	The diameter of the tube is not limited.
4	The process is simple.	Complex shape tubes can be drawn
5	The fixed shape of the wire can be drawn	Complex shape tubes can be drawn

### 11. Describe the principle of Hydrostatic extrusion [APR/MAY-2010, NOV/DEC 2013]

Hydrostatic extrusion is a process in which the billet is completely circumscribed by a pressurized liquid in all the cases, with the exception being the case where the billet is in contact with the die. This process can be carried out in many ways including warm, cold or hot but due to the stability of the used fluid, the temperature is limited. Hydrostatic extrusion has to be carried out in a completely sealed cylinder for containing the hydrostatic medium. The fluid may be pressurized in following two ways

**a. Constant rate extrusion:** A ram of plunger is used for pressurizing the fluid in the container

**b. Constant pressure extrusion:** A pump with a pressure intensifier is used for pressurizing the fluid, which is then pumped into the container.



*Figure: Hydrostatic extrusion*

**Advantages of Hydrostatic Extrusion:**

- No friction amidst the container and billet. This minimizes the force requirements allowing higher reduction ratios, faster speeds and lower billet temperatures.
- Friction of the die can be largely reduced by a film of pressurized lubricant amidst the die surface and deforming metal.
- Even flow of material
- Large billets and large cross-sections are extruded
- Uniform hydrostatic pressure inside the container eliminates the requirement of billets being straightened and extrusion of coiled wire.
- No billet residue is left on the walls of container.

**Disadvantages of Hydrostatic extrusion:**

- The billets have to be prepared by tapering one end so that it matches the die entry angle. This is essential for forming a seal at the starting of the cycle. Generally, the complete billet is required to be machined for the removal of surface defects.
- It can be difficult to contain the fluid, under the effects of high pressures
- Increased handling for the injection and removal of the fluid for every extrusion cycle
- Decreased process efficiency in terms of billet to container volume ratio
- Enhanced complication when extrusions is done at elevated temperatures.

**12. What is smith forging operation? [NOV/DEC-2011]**



## SMITH FORGING

The process involves heating the stock in the blacksmith's hearth and then beating it over the anvil. To get the desired shape, the operator has to manipulate the component in between the blows. The types of operations available are fullering, flattening, bending, upsetting and swaging.

In fullering, the material cross-section is decreased and length increased. To do this, the bottom fuller is kept in the anvil hole with the heated stock over the fuller. The top fuller is then kept above the stock and then with the sledge hammer, the force is applied on the top fuller. The fullers concentrate the force over a very small area, thus decreasing the cross-section at that point. Metal flows outward and away from the centre of the fullering die. Then the stock is advanced slightly over the fuller and the process repeated, as shown in Fig. 19.2.

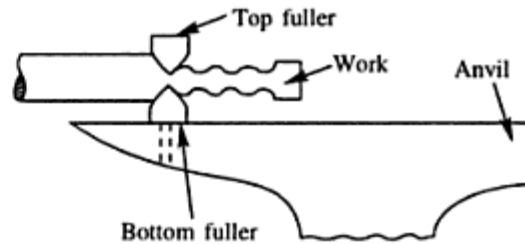


Fig. 19.2 Fullering operation

After fullering, the stock would have the fullering marks left which are then cleaned by means of flattening. To obtain specific shapes such as round, square, hexagon, etc. open general purpose dies called swages are used. The force for shaping is applied by manual hammering or by means of the forging hammers, the latter being the industrial practice.

Smith forging involves a lot of skill on the part of the operator and also is more time consuming. But since no special dies are used, smith forging is more beneficial in the manufacture of small lots or in trial production, because of the heavy cost of the closed impression dies cannot be justified in these cases.

13. Briefly explain what are compound dies and progressive dies, with suitable sketches. [NOV/DEC-2011]

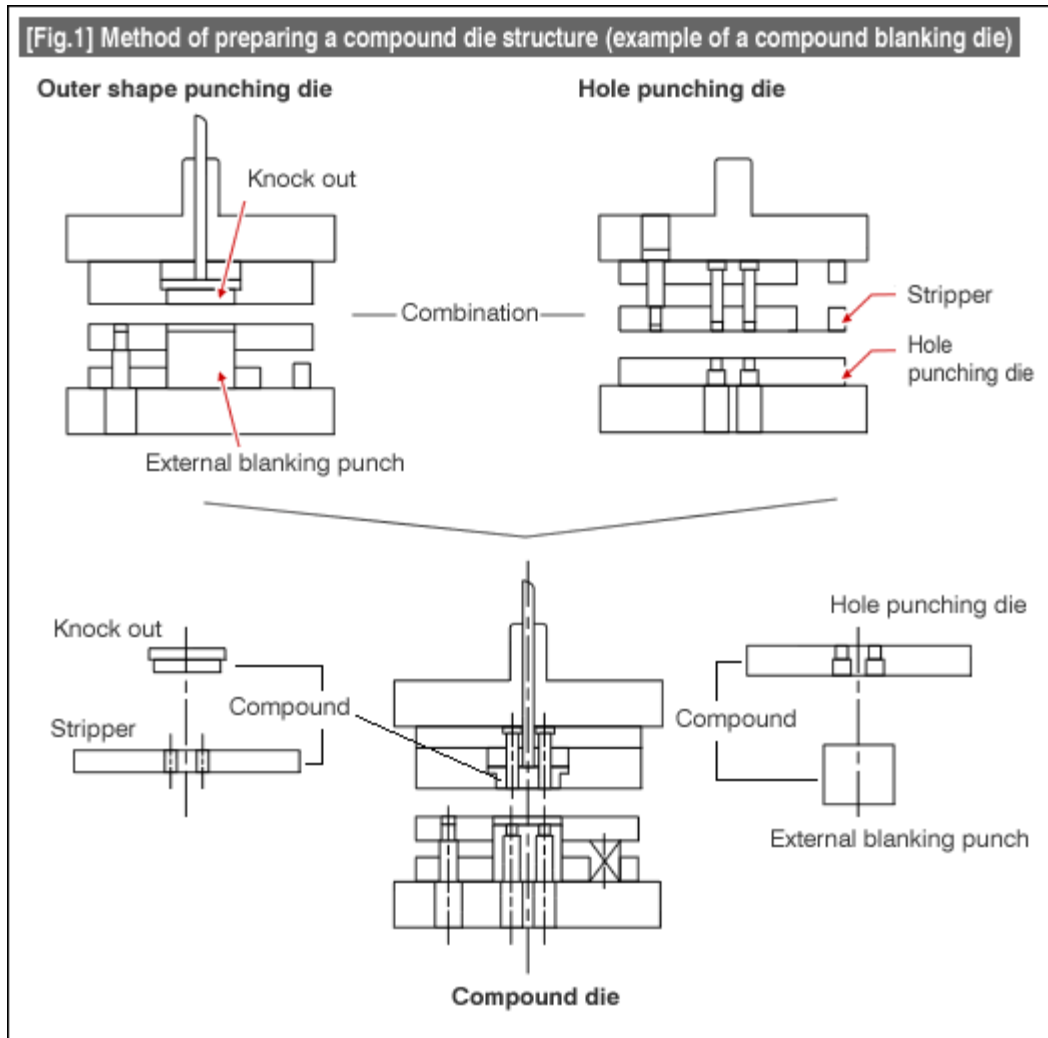
### compound dies:

The structure for compound work such as compound blanking or blanking and drawing, etc., is made by combining the basic die structures. In such work, the outer shape (the blank) is prepared, and then additional work is made on it (such as hole punching, or drawing (extruding)).

In general, very often during such work the blank is punched upwards and the additional hole punching, etc. is done downwards. The basic die structures that permit such work are selected respectively and combined thereby creating a compound die structure.

An example of a compound die is explained below. See [Fig. 1].





In compound press work, the die carries out external shape punching and hole punching simultaneously. This is used because of its good aspects such as a good positional relationship between the external shape and the hole, even good flatness of the product, and that the direction of burrs is the same in the external shape and the hole. Apart from this, there is also the advantage that the process can be shortened. However, since there is the disadvantage that, since the product enters the die (the top die), problems in taking out the product can easily occur.

The external shape forming work in [Fig. 1] uses a reverse placement variable stripper type structure and the product is removed upwards. Hole punching is done as usual downwards using the forward placement variable stripper type structure. Because of this relationship, the problem of processing the scrap in hole punching will not be there. These two types of dies are combined into one unified structure. During such unification, the parts that are not common are left as they are. Two of each of the parts that interfere with each other, the external shape blanking punch, the hole punching die, the stripper, and the knock out are combined together and made into single parts. Such parts are called compound parts. The compound die structure is completed because of using these parts.

When interfering parts are unified at the time of carrying out compound work, a judgment should be made as to whether the shape is suitable as a part of the die and as to whether there is any problem in terms of the strength, and the compound die is realized if there is no problem.

Since compound blanking or compound drawing or extrusion are used very frequently, even their structures are found in reference documents and they are used in a manner similar to ordinary dies, and hence these types of structures are used. Even compound dies for hitherto unknown compound works can be prepared using the procedure as described here.

### **Progressive die:**

The sheet metal is fed through as a coil strip, and a different operation (such as punching, blanking, and notching) is performed at the same station of the machine with each stroke of a series of punches.

For components having relatively simple configuration, the progressive tools are used. Here there will be a single press. The tool will have multiple stations. The component is not separated from the strip. The material (strip) keeps on moving along with the die, perfectly equal moments (called pitch). The component will be isolated at the final stage

**14. (i) With a neat sketch, explain the working of a Pneumatic Hammer for forging. (MAY/JUNE 2012) – REFER QUESTION NO. 2**

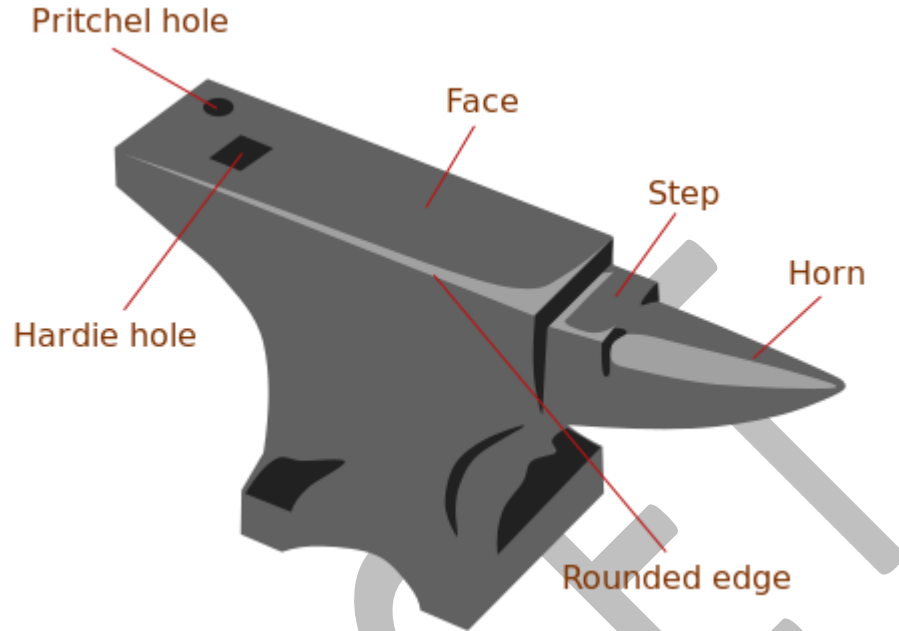
**(ii) List four tools used for forging. Sketch any two of them. (MAY/JUNE 2012)**

The various tools used for forging process are

- Anvil
- Hammer
- Chisel
- Tongs
- Fuller
- Hardy

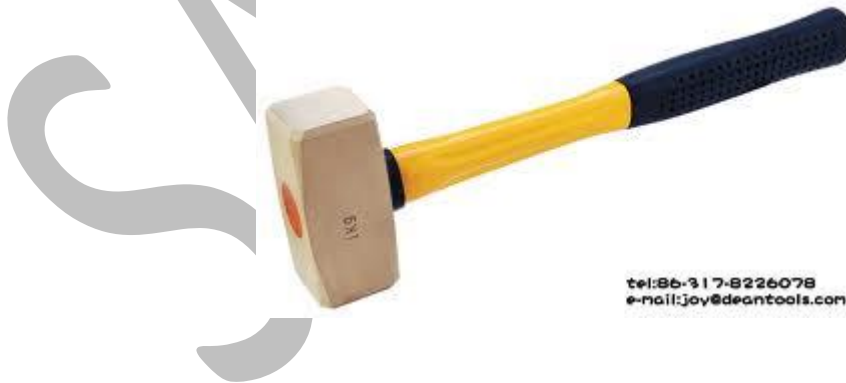
### **Anvil**

The anvil serves as a work bench to the blacksmith, where the metal to be forged is placed. Anvils are made of cast or wrought iron with a tool steel face welded on or of a single piece of cast or forged tool steel. The flat top has two holes; the square hole is called the hardy hole, where the square shank of the hardy fits. The smaller hole is called the punch hole, used as a bolster when punching holes in hot metal.



### Hammer

There are two types of hammer are used in workshop. (1)Hand hammer :it is used by smith himself. (a)ball peen hammer (b)cross peen hammer (c)straight peen hammer (2)Sledge hammer :it is used by striker.



tel:86-317-8226078  
e-mail:joy@deantools.com

### Chisel

**Chisels** are made of high carbon steel. They are hardened and tempered at the cutting edge while the head is left soft so it will not crack when hammered. Chisels are of two types, hot and cold chisels. The cold chisel is used for cutting cold metals while the hot chisel is for hot metals. Usually hot chisels are thinner and therefore can not be substituted with cold chisels

### Tongs

Tongs are used by the blacksmith for holding hot metals securely. The mouths are custom made by the smith in various shapes to suit the gripping of various shapes of metal. There are various types of tongs available in market. (1)flat tong (2)rivet or ring tong (3)straight lip fluted tong (4)gad tong

### Fuller

Fullers are forming tools of different shapes used in making grooves or hollows. They are often used in pairs, the bottom fuller has a square shank which fits into the hardy hole in the anvil while the top fuller has a handle. The work is placed on the bottom fuller and the top is placed on the work and struck with a hammer. The top fuller is also used for finishing round corners and for stretching or spreading metal.

### Hardy

The hardy is a cutting tool similar to the chisel. It is used as a chisel or hammer for cutting both hot and cold metals. It has a square shank that fits into the hardy hole in the anvil, with the cutting edge facing upwards. The metal to be cut is placed on the cutting edge and struck with a hammer. They are also used with set tools which are placed over the workpiece and struck.

### 15. (i) With neat sketches , explain the different types of roll stand arrangements used in the rolling mills. (MAY/JUNE 2012)

The three principal types of rolling mills used for the rolling of steel are referred to as two-high, three-high, and four-high mills. This classification is based on the arrangement the rolls in the housings. Major features of those stands are listed below:

- two-high stand: consisting of two rolls, one above the other. On two-high reversing mills, the direction of rotation of the rolls can be reversed, and rolling is alternately in opposite directions.
- three-high stand: with three rolls, each of them revolves continuously in one direction; the top and bottom rolls in the same direction and the middle roll in the opposite direction. The piece is lifted from the bottom pass to the return top pass by mechanically-operated lift tables, or by inclined approach tables. Usually the large top and bottom rolls are driven, while the smaller middle roll is friction driven.
- four-high stand: with four rolls, particularly used for rolling flat products, like sheets and plates, for both hot and cold rolling. The large backing-up rolls are employed to resist the tendency of long working rolls to deflect, and to permit the use of small-diameter working rolls for producing wide plates.

For rolling thin product, such as sheet, smaller rolls are preferred. At one hand, smaller rolls require smaller roll load. On the other hand, smaller rolls have lower elastic deformation and make it possible to roll the sheet to a thinner gauge. If the sheet thickness is equal to near to the roll elastic deformation, the sheet thickness cannot be reduced any more - this is the minimal thickness that can be rolled.

However, a small roll has big roll deflection which makes the things worse if no backup roll works with it. In practice, there are also six-roll, twelve-roll, and twenty-roll arrangements, beside four-roll mills. The more the rolls, the smaller the possible work roll diameter, and consequently, the high the cost. Fig. 1 shows the major roll arrangements mentioned above. While four-high mill can be used for both hot and cold rolling, the six-high, twelve-high and twenty-high mills are primarily used to roll very thin cold sheet.

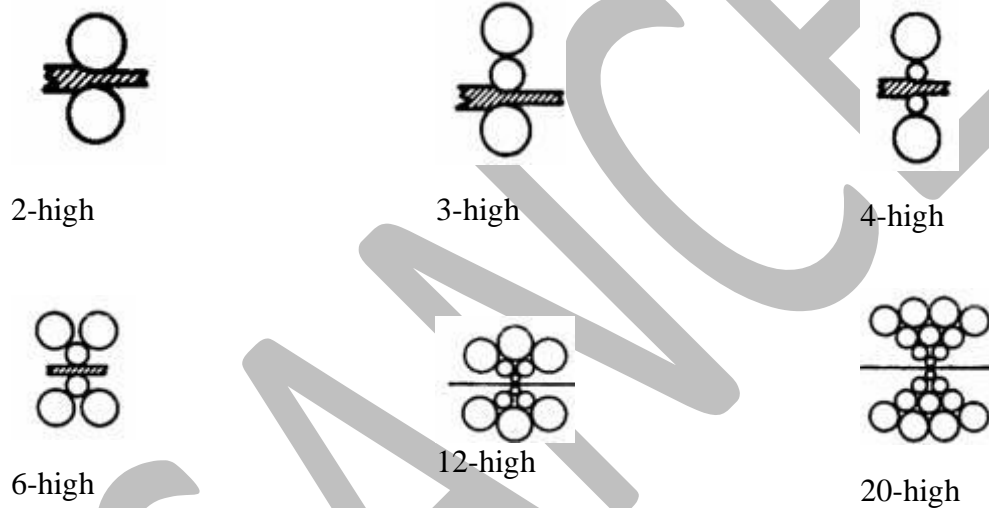


Fig. 1: Major roll arrangements for flat rolling

Fig. 2 illustrates a three-high reversing mill, with guides and guards displayed. For reversing mill, both sides of the mill need to be provided with guides and guard. Guides are employed in order to prevent collaring and to insure that the piece enters and leaves the pass in the correct position, while guards are used mainly on the delivery side of the mill to control the direction of the piece after leaving the pass.

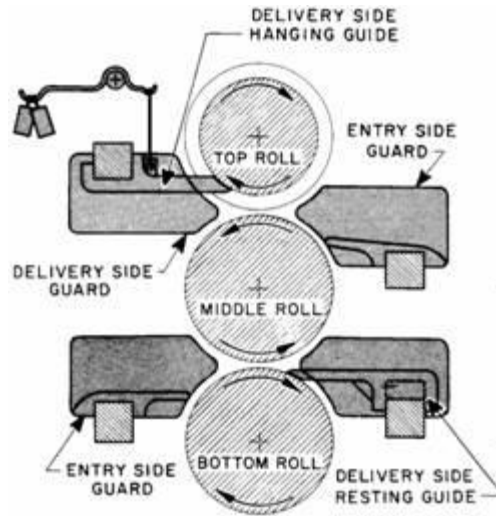


Fig. 2: A three-high reversing mill with guides and guards

There are also several other arrangements of rolls. One example is the Sendzimir planetary mill (Fig. 3) and Taylor mill. In the planetary mill, a great number of small rolls, which in turn serve as work rolls, are mounted on the surface of two large backup rolls. Since multiple sets of rolls work on the strip simultaneously, the pass reduction can be very high. In Fig. 3, due to the high complicity, a pair of feed rolls are installed.

Other roll arrangements, such as universal mill and three-roll mill (e.g. Kocks mill), are discussed in a separate paper on shape rolling rolls and mill arrangements.

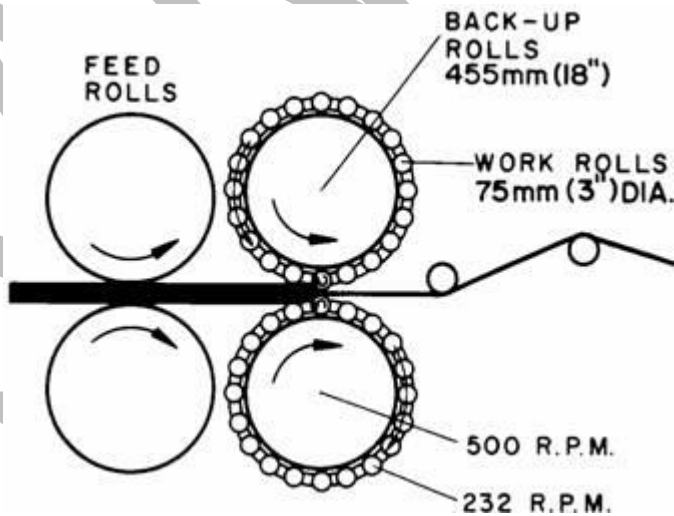


Fig. 3: Planetary mill [21]

A continuous mill consists of several stands of rolls arranged in a straight line (in tandem), with each succeeding stand operating with roll surface speed greater than its predecessor. This type of mill is in very common usage for rolling strip, sheet, billets, bars, rods, etc. Any part of the workpiece, after pass through the roughing, intermediate and finish stands, is rolled from initial

shape into the finish one, and emerges from the last roll stand. A semi-continuous mill comprises also a reversing roughing stand for reducing the piece prior to entering the continuous mill for reduction to the finished shape. This arrangement gives moderately high production with lower first cost than a continuous mill.

**(15) State clearly for what purpose each arrangement is used. (MAY/JUNE 2012)**

The operation in which we decrease the thickness of the plate by increasing the length with the help of cylindrical rolls is known as rolling process. There are number of arrangements used in practical life for rolling operation.

This arrangement gives moderately high production with lower first cost than a continuous mill.

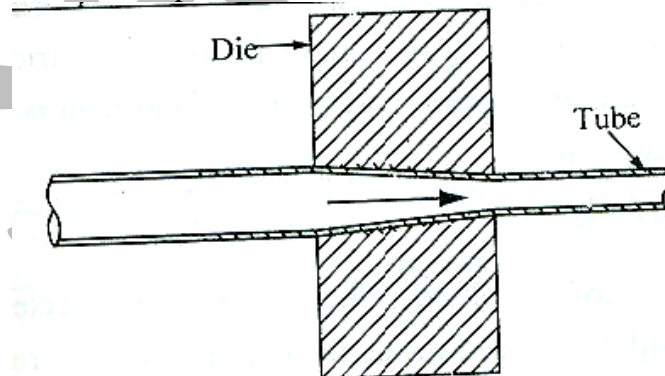
**(16) With a neat sketch, explain the principle used in tube drawing process ? (MAY/JUNE 2012)**

Tube piercing is nothing but tube drawing with mandrel. In tube drawing, cylinders and tubes which are made by extraction process in finished by drawing process.

Tube drawing is classified into

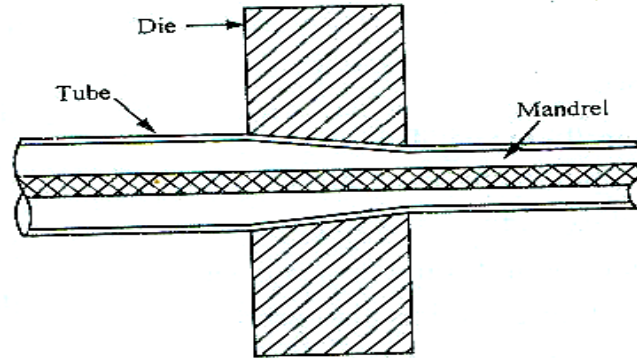
1. Tube sinking
2. Tube drawing with plug
3. Tube drawing with mandrel

In tube sinking process, the outer diameter of the tube only reduced. For reducing the inner diameter of the tube the other two process.

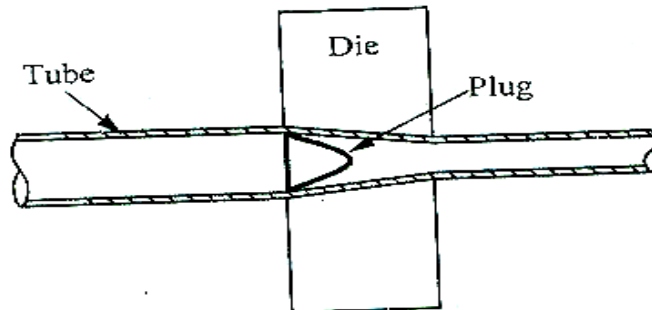


**Fig Tube sinking**

i.e., tube drawing with plug or Tube drawing with mandrels is used.

**Fig Tube mandrel**

In tube mandrel, the mandrel is placed in the tube and the pull is given to the tube. It will reduce the inside diameter of the tube.

**Fig Tube plug**

In plug drawing, both internal and external surface of the tube is controlled and the dimensional accuracy is good compared with other two methods. In this process the plug is fixed or floating. The friction obtained in fixed plug is more than floating plug and drawing load is high in fixed plug and less in floating plug.

**16. With neat sketches. Explain the following smith forging operations. (NOV/DEC 2012)**

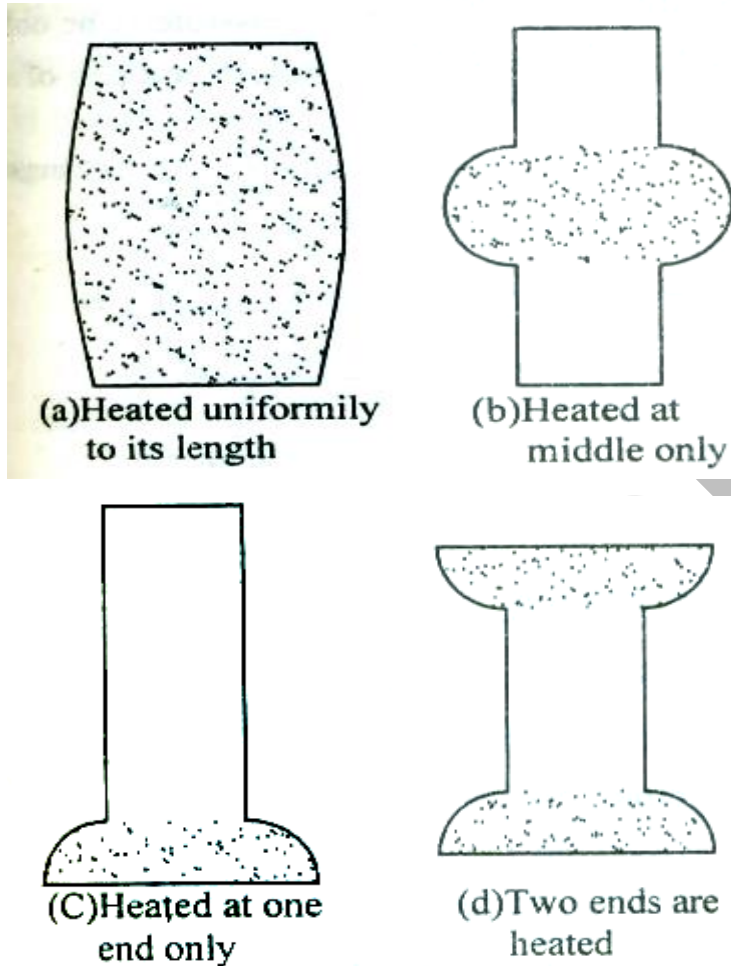
- i. Upsetting
- ii. Bending
- iii. Swaging
- iv. Fullering
- v. Punching and drifting
- vi. Edging

**i. Upsetting**

This process is called as hot heading. In this operation, the metal is heated at one end and it is rest on the anvil and force is applied on the other end by using hammer. So, this force will increase the cross sectional area and decrease the length. This operation of reducing cross sectional area is



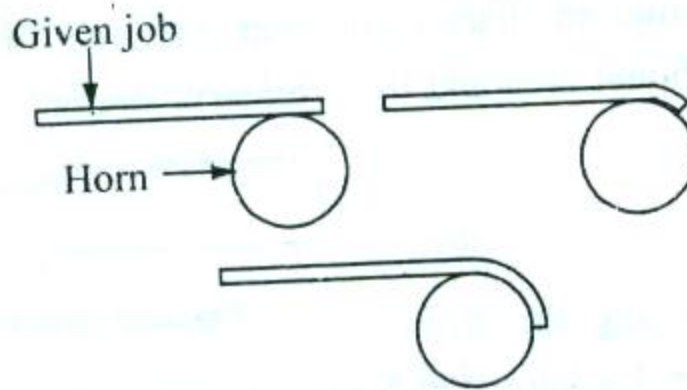
known as **upsetting**. The equipment used in this operation is called is called upsetter.



The dies used on these machines are so designed that the complete operation is performed in several stages and the final shape attained gradually. The operation is performed with the help of a die and a punch

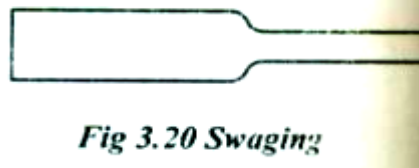
### ii. Bending

Shapes like angles, ovals, and circles etc can be done by this method. Befor going to this operation, the job is heated in the appropriate portion. Then the job is placed over the anvil (over the horn) and the force is applied through the hammer. Bending of bars, flats are done in smithy shop for making a right angle bend that particular portion of stock is heated and jumped on the outer surface. So, it provides an extra material at that particular place which compensates for the elongation of the outer surface due to hammering during bending. After bending, the outside bulging is finished by means of a flatter but the inside one by means of a set hammer. For mass production of bending , jigs and fixtures are used.



### iii. Swaging

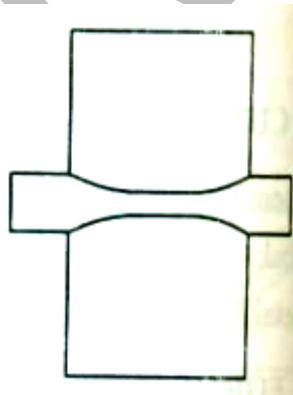
Reducing or changing the cross sectional area of the metal is known as **Swaging operation**.



*Fig 3.20 Swaging*

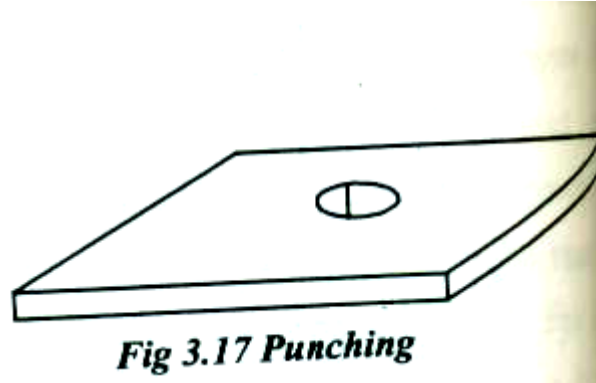
### iv. Fullering

Reducing the stock or job and increasing the length of the work piece by applying pressure on it is known as **fullering**



### v. Punching and drifting

Punching is defined as making of a hole in a given job. The principle operation of this process is placing the heated job over a correct hole of the swage or die and forcing the punch into it by hammer. The work piece is initially heated to nearly white heat and then placed flat on the anvil face. If a small hole is to be produced, the second stage of the operation can be performed by placing the work on the anvil face.



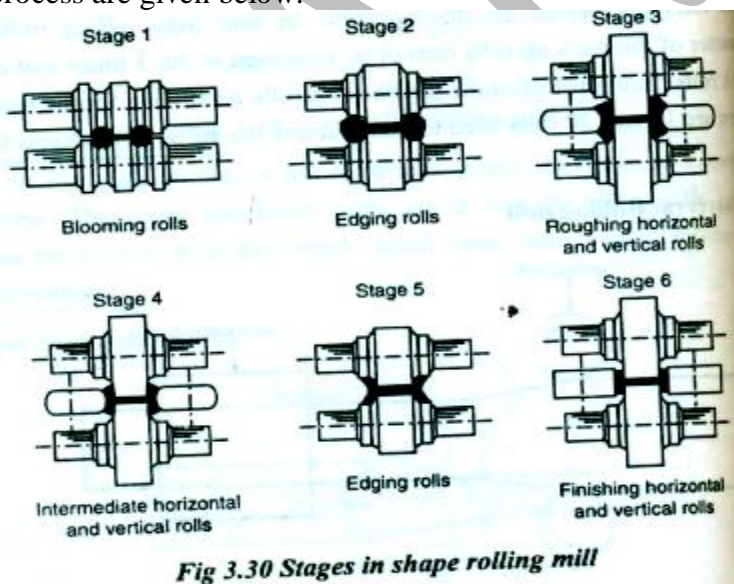
**Fig 3.17 Punching**

11. With suitable sketches. Explain the following: (NOV/DEC 2012)

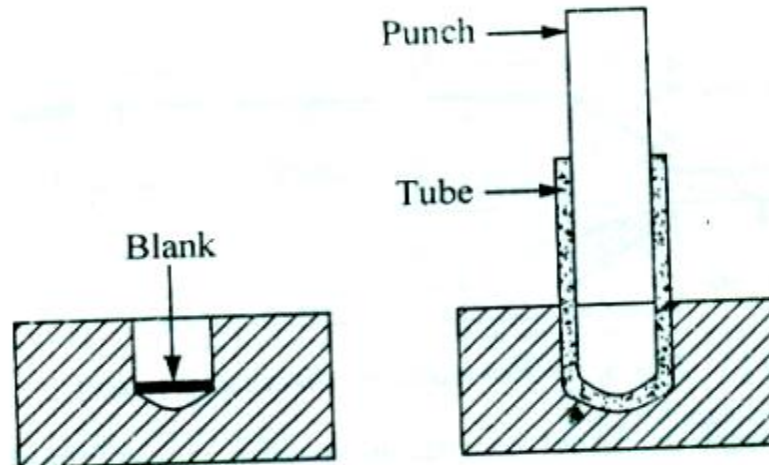
- i. Stages involved in “Shape rolling” of structural sections .
- ii. Cold extrusion forging
- iii. Seamless tube drawing[AU-MAY/JUNE-2013] [Refer Pg.No:26, Q.No: 16]

**i. Stages involved in “Shape rolling” of structural sections .**

In shape rolling process the various shapes can be produced. Example: Straight and long structural shapes, solid bars, I-beams, Channels, railroad rails. The various stages in shape rolling process are given below.



**ii. Cold extrusion forging**



This process also called cold extrusion. Working principle of this process is that work material is placed between the die and ram. The punch is connected with the ram. When the sudden impact is given to the ram, the metal flows plastically in the upward direction, metals like aluminum, tins are extruded in an Impact extrusion.

The various items of daily use such as tubes for shaving creams, tooth pates and paints, condenser cans and tin walled products are impact extruded. The metal flows up along the surface of the punch, forming a cup shaped component. When the punch moves up, the compressed air is used to separate the component from the punch. The production rate is fairly high, giving about 60 components per minute. The main advantages of this process, it speed product uniformity and low scrap yield.

### 12. Briefly explain about flat strip Rolling. [AU-MAY/JUNE-2013]

In rolling plates and sheet with high width to thickness ratios, the width of the material remains essentially constant during rolling process. For square section, the width increases considerably in the roll gap. The increase in width of a strip in flat rolling is shown in fig.

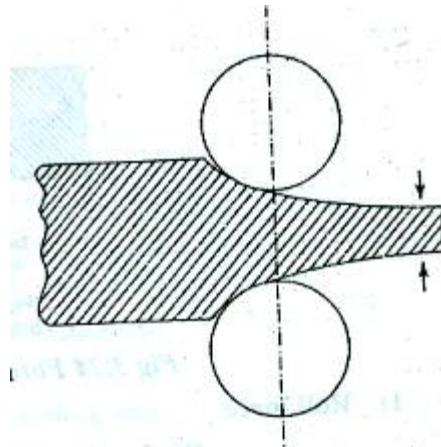


Fig 3.23. Flat strip rolling

The increased width in rolling is called spreading. For calculating the rolling force, the width is taken as average width. The spreading can be prevented by using vertical rolls.

The schematic diagram of flat strip rolling is shown in fig. The thick of strip  $h_0$  is reduced to  $h_f$  by a pair of rotating mills. The velocity of the strip increases from  $v_0$  to  $v_f$ . Since the surface speed of the roll is constant in the roll gap  $L$ .

The frictional forces which are acting on the flat strip and the roll force and power requirement for the rolling

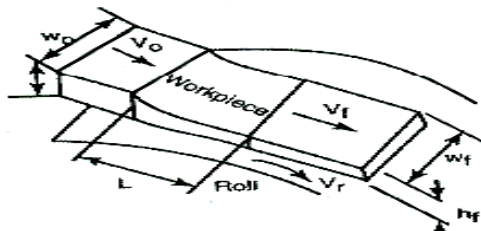


Fig. (a) Flat rolling process

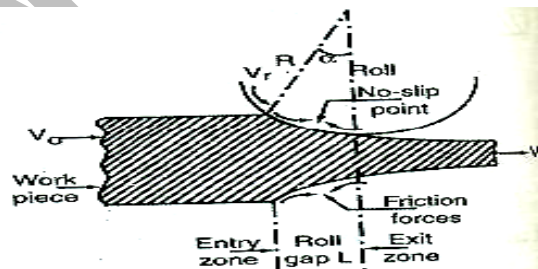


Fig. (b) Friction force acting on strip surfaces

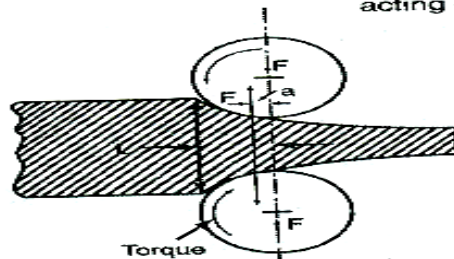


Fig. (c) Roll force acting on the rolls.

Fig 3.24 Forces acting on flat strip

**1.Roll force:**

$$F=LW Y_{avg}$$

Where,L=Roll strip contact length

W=Width of the strip

$Y_{avg}$ =Average of the true stress

**2.Power per roll**

$$\text{Power}=\frac{2\pi FLN}{6000} \text{ kW}$$

Where,F=Force in Newton

N=Speed of the roll in rpm

**3.Roll strip contact length(L):**

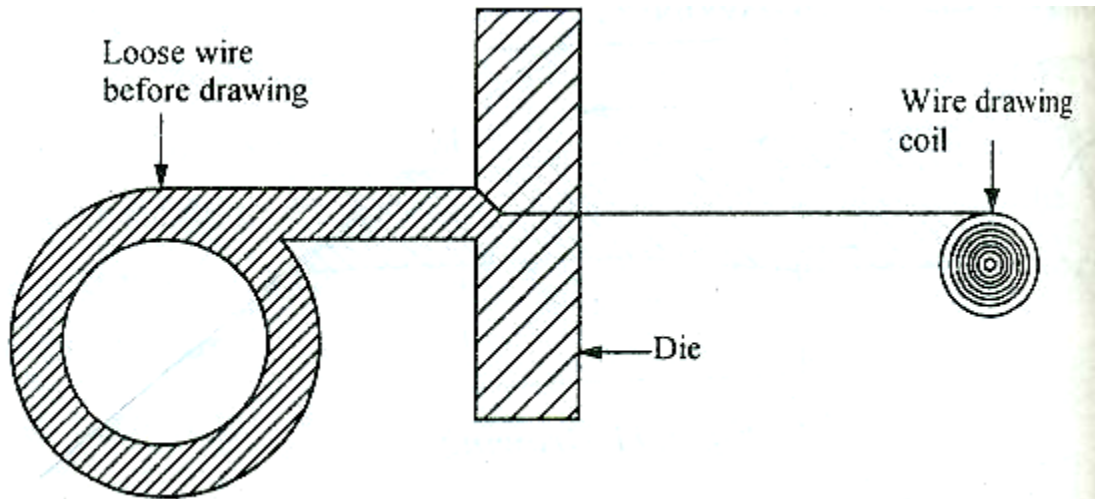
$$L=\sqrt{R(h_0-h_f)}$$

$h_0-h_f$ =Difference between initial and final thickness

R=Roll radius

**13.Explain with a neat sketch the process of wire drawing. [AU-MAY/JUNE-2013]**

The diameter less than 16 mm has drawn in the form of wire coil. Initially the point of the wire is sized so it is freely enter into the die.



**Fig 3.42 Wire drawing**

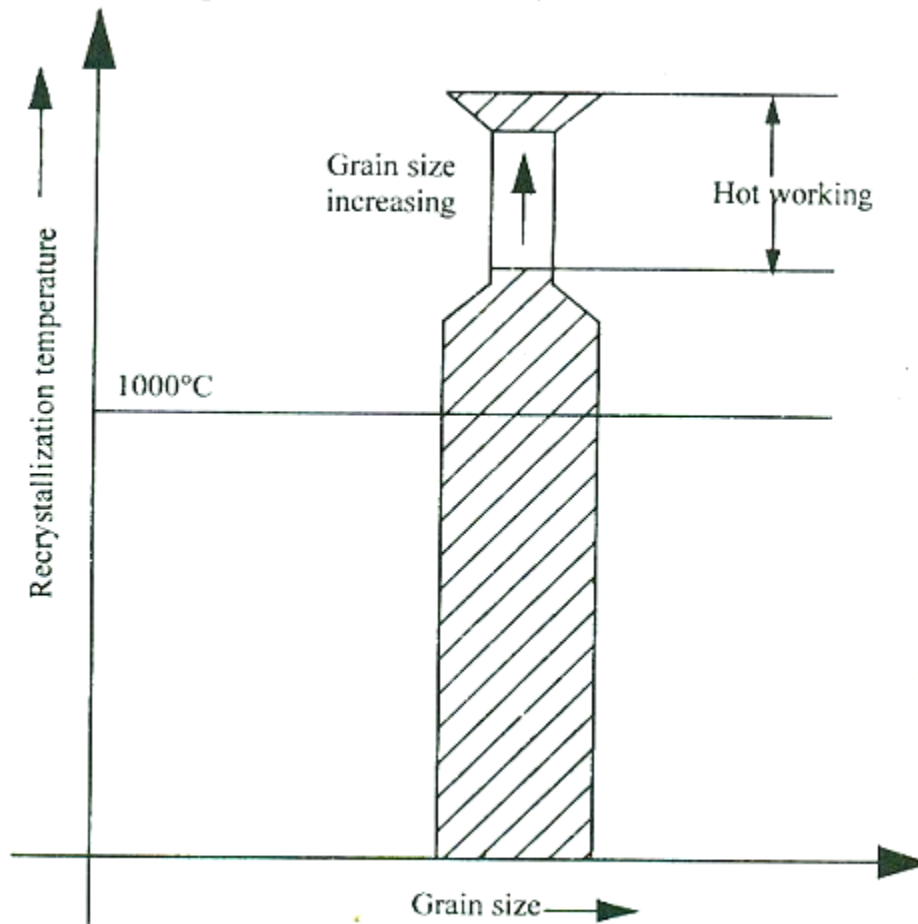
This sized point coming out of the orifice is fixed on the pliers or carriage, which pulls the rod through all the zones of the die orifice. That will reduce the number of dies. Finally the wire is connected to the power reel to get the wire coil.

**14. Explain with neat sketch Hot working and Cold working of metals. [AU-MAY/JUNE-2013]**

#### **HOT WORKING OF METALS:**

Mechanical working of a metal above the recrystallization temperature but below the melting point is known as hot working. It may also be defined as the plastic deformation of metals and alloys under the conditions of temperature and strain rate





*Fig 3.1 Hot working of metal.*

In this process the metal is heated above the recrystallization temperature of the metal but below the melting point of metal. Normally the recrystallization temperature of metal will be about 30 to 40% of its melting temperature.

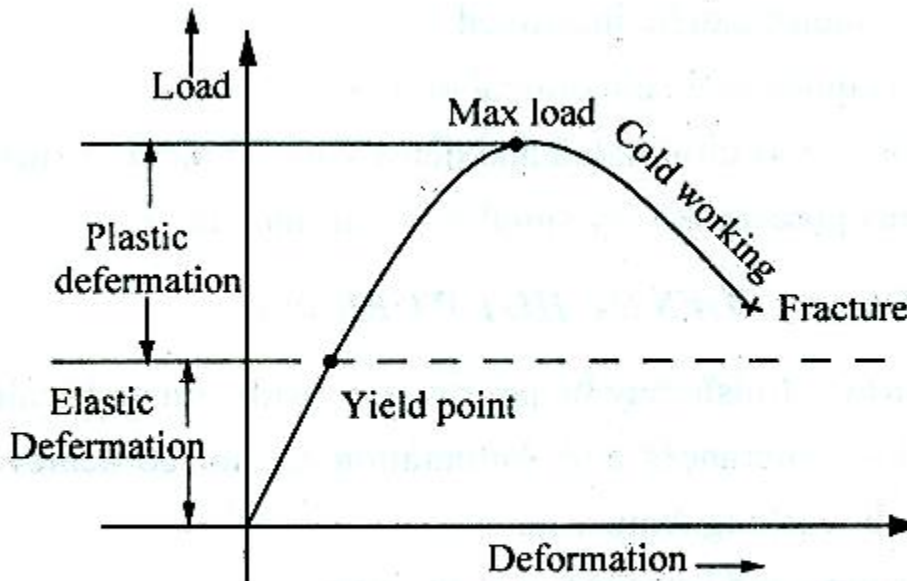
#### **ADVANTAGES:**

- Force requirement is less when compared to cold working process for making the required shape.
- As grain structure is refined, toughness, ductility and resistance can be improved
- It is quick and economical process
- Porosity is eliminated and density of the metal is increased
- This process is very suitable for all metals



**DISADVANTAGES:**

- Surface finish may be poor due to oxidation and scaling
- Close tolerance and automation cannot be achieved due to high working temperature.
- Tooling and handling cost are high.
- Sheets and wires cannot be produced.

**COLD WORKING:**

**Fig 3.2 Load deformation curve**

Plastic deformation of a metal to the required shape being performed below the recrystallisation temperature is known as cold working process.

The recrystallisation temperature is defined as the minimum temperature at which the complete recrystallisation of a metal takes place within a specified time. The recrystallisation temperature is about one half of the absolute melting temperature but generally cold working is carried out only at room temperature.

**ADVANTAGES:**

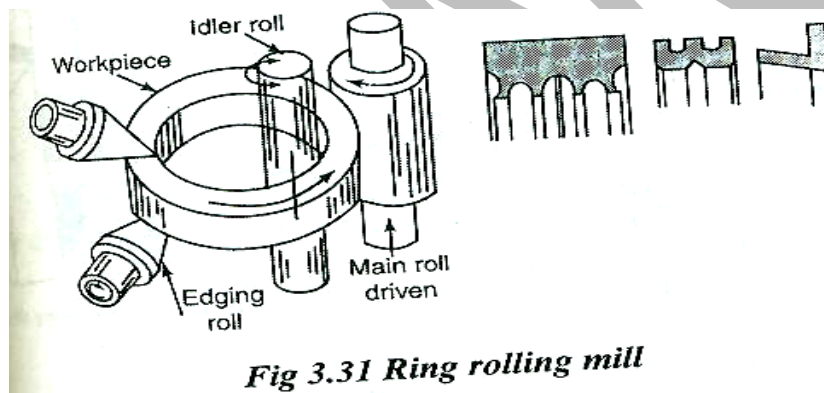
- It is widely applied as a forming process for steel
- Better surface finish is being obtained
- This process provides higher dimensional accuracy
- Thin material can be obtained
- It is more suitable for mass production.

**Limitations:**

- The surface finish may be poor.
- Close tolerance cannot be achieved
- Stress formation in the metal during cold working is higher.

**15. Explain with neat sketch of Roll Ring Process. [AU-MAY/JUNE-2013]**

In ring rolling process, a thick ring is expanded into a large diameter ring with a reduced cross section. First, the ring is placed in between the two rolls and one of the roll is driven and the ring thickness is reduced by bringing the rolls closer together as they rotate.



**Fig 3.31 Ring rolling mill**

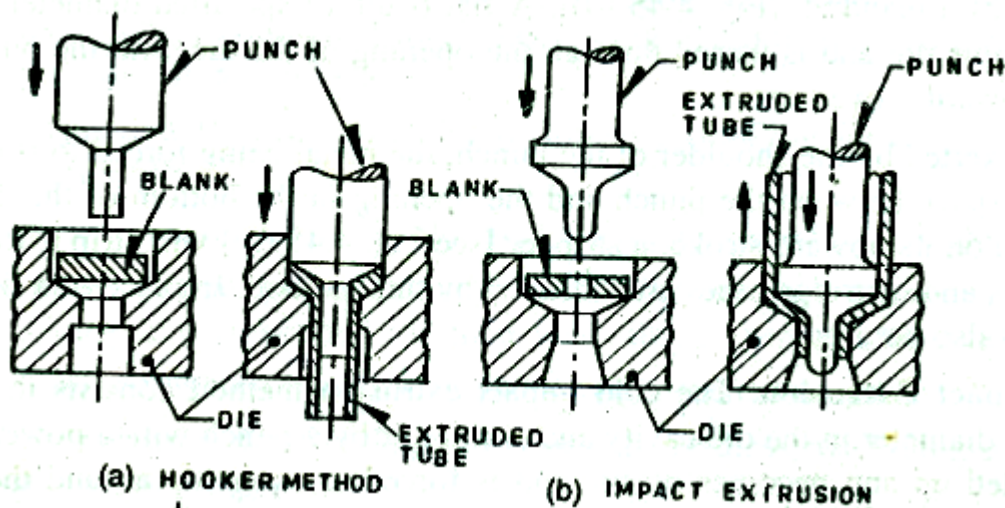
The reduction in thickness of the ring is compensated by an increase in the rings diameter. The figure shows procedure for producing a seamless ring for a tapered roller bearing.

The ring rolling process has the advantages of short production times, close tolerances, material savings. It can be carried out at room temperature depends upon the size, strength and ductility of the material.

**16. Write short notes on impact extrusion process. (Nov/Dec 2013)**

The cold impact extrusion method consists in placing a flat blank of specified diameter in the die cavity and striking it by a punch with a powerful blow. The materials get heated up and become plastic and is forced to squirt up around the punch, shown in (figure).

Thin walled tubes of low flow strength materials (tin, lead, aluminium etc.) are rapidly formed by this method. The end of the tube will correspond to the shape of the die cavity and also of the punch. The outside diameter of the tube takes the shape of the die and the wall thickness is equal to the clearance between the punch and the die. The operation is fully automatic and the production rate is as high as 50 tubes or more per minute.



When the punch is on its upward stroke, the tube sticks to it. To effect release, either a stripper (shown in figure) or compressed air is directed against the tube, thus stripping it from the punch. Threads may be formed at the end of these collapsible tubes by retractable die portions or by other methods. These collapsible tubes are used for cosmetics (cream, shaving cream), tooth paste, grease etc.

**Other product applications include:** Cans, fire extinguisher cases, radio shields, food containers, boxes for condensers and cigarette lighter cases.

**UNIT-IV**  
**SHEET METAL PROCESSES**  
**TWO MARKS**

**1. What is spring back? How is it recovered? (APRIL/MAY 10, 12, 13, NOV/DEC 13)**

Spring back is defined as the movement of the metal to resume its original position causing a decrease in bend angle after the applied force is withdrawn.

It is recovered by techniques such as over bending.

**2. What is peen forming? What are its application? (APRIL/MAY 2010)**

Peen forming is a process of well established surface cleaning. In this process, a stream of metal shots is blasted against the surface of the blank to be made into required shape.

**Application**

1. this process is used in producing specific portions on crankshafts, connecting rods and gears

2. it is used for producing honey comb panels like aircraft wings and large tubular shapes.

**3. What is ironing, applied to sheet metal work? (NOV/DEC.2011)**

The process of reducing wall thickness and lengthening of the cup is known as ironing. Annealed cups can be reduced to 50% of wall thickness.

Volume before ironing = Volume after ironing

$$\pi d t h = \pi d t_1 h_1$$

Where, d = diameter of the cup

t = blank thickness

t<sub>1</sub> = reduced thickness or die clearance

h = height of the cup

h<sub>1</sub> = increased height

**4. What are the advantage of Rubber Pad Forming process? (NOV/DEC.2011)**

- The process is more economical.
- Tooling cost is high.
- Many required shapes can be formed in one rubber pad itself.
- There is no need of lubricants.
- No thinning metal takes place.
- Tool setting time is less.
- Deeper shells can be drawn.
- Parts produced are wrinkle-free, shrink flanges and improved shallow shapes

**5. What are the advantages of hydro forming process. [MAY-2012]**

- ❖ Complicated contours can also be made.
- ❖ Sharp corners are also possible.
- ❖ All types of sheet metals can be handled.
- ❖ It is used for mass production because work performed per operation is high.

- ❖ Tool changing can be done rapidly.
- ❖ Due to uniform flow metal between punch and pressure chamber, the mechanical and physical properties are improved.

**6. What are the limitations of explosive forming. [NOV-2012]**

1. Highly trained operators are needed.
2. Noisy operation.

**7. What is lancing operation that is done on sheet metals? [NOV-2012]**

Lancing consists of cutting the sheet metal through a small length and bending this small cut portion downwards.

**8. What is sheet metal work? (APRIL/MAY 2013)**

The working of metal thickness from 3mm to sum with hand tools and simple machines into various forms is known as sheet metal work.

**9. List the various major shearing operations in sheet metal. (Apl/May-2019)**

- Shearing
- Bending
- Drawing
- Squeezing

**10. What is meant by clearance? (Nov/Dec 2008)**

Clearance is the intentional space between the punch cutting edge and the die cutting edge. Depends on the type of cutting operation, the space between punch and die is provided known as clearance.

**11. Define the term “spring back “(May/June 2005) (Nov/Dec-2018) (Apl/May-2019)**

Spring back is defined as the movement of the metal to resume its original position causing a decrease in bend angle after the applied force is withdrawn.

**12. List out the applications of stretch forming operations.**

- Production of aircraft using and fuselage parts.
- Production of contoured panels for truck trailer and bus bodies in automobile industry.

**13. What are the formability test methods?**

- Formability tests for bulk deformation.
- Formability test for elastic plastic deformation
- Simulative tests for forming operation
- Full scale forming tests.

**14. What is punching operation? (May/June 2005)**

Punching is defined as making a hole in a given job. The principle operation of this process is planning the heated job over a correct hole of the swage or die and forcing the punch into it by hammer.

**15. What is super plastic forming operation? (Nov/Dec 2007)(Nov/Dec-2018)**

Super plasticity in metals is defined by very high tensile elongations, ranging from two hundred to several thousand percent. Super plasticity is the ability of certain materials to undergo extreme elongation at the proper temperature and strain rate.

The process typically conducted at high temperature and under controlled strain rate, can give a ten – fold increase in elongation compared to conventional room temperature process.

**16. Give the difference between punching and blanking**

Punching: it is the operation of producing the hole on the work piece.

Blanking: it is the operation of cutting a flat shape from the sheet metal.

**17. How is hydro – forming similar to rubber forming (Nov/Dec 2007)**

In this forming method, a rubber diaphragm or seal is used for making perfect scaling between male and female die

**18. What are the types of special forming process? (Nov/Dec 2008)**

- Hydro forming
- Rubber pad forming
- Metal spinning
- Explosive forming
- Magnetic pulse forming
- Peen forming
- Super plastic forming

**19. Describe power spinning process? (April/May2004)**

In power spinning process, the action of form tool is controlled either by any tracer mechanism or by numerical controls (NC) now - a - days , computer controlled numerical machines are used to change the shape of contour whenever we want from the existing program.

**20. How magnetic pulse is created? (April/May2008)**

The basic principle is that discharging of a capacitor through a coil over a period of microseconds, on the blank to obtain the required shape. During this, the magnetic flux densities of the order of hundred of kilogauss can be produced.

**21. What are the applications of super plastic forming? (April/May2004)**

- In automotive body panels
- In forming of aircrafts frames and skins
- Diaphragm forming of plastics
- Complex shape part – window frames seat structures.

**22. What do you mean by minimum bend radius?**

The outer surface of material is in tension and inner surface is in compression the bend in material increases with decreasing radius of curvature

**23. Define limiting drawing ratio. (May/June 2006)**

The volume of material removed from the work per unit volume of wear. This ratio is called limiting drawing ratio.

**24. Define “embossing”**

It is the process of producing required shapes on sheet metal blanks by means of punches and dies.

**25. Write the shot notes on hydro forming.(Nov/Dec-2018)**

Hydro forming is a specialized type of die forming that uses a high pressure hydraulic fluid to press room temperature working material into a die. To hydro form aluminum into a vehicle’s frame rail, a hollow tube of aluminum is placed inside a negative would that has the shape of the desired end result.

**26. What is metal spinning process? (May/June 2006)**

The process of forming seamless metal parts from a circular sheet metal or from a tube length on a lathe is called as spinning process.

**27. State the various methods of spinning.**

- Manual spinning
- Power spinning

**28. Name the various processes can be performed by explosive process.**

Blanking, cutting, expanding, coining, embossing, flanging, power compacting, drawing and sizing operation etc..

**29. What is peen forming process? (April/May2008)**

Peen forming is a process of well established surface cleaning. In this process, a stream of metal shots is blasted against the surface of the blank to be made into required shape.

**30. Mention the various types of simulative tests carried out for various cup forming.**

- Erickson test
- Olsen test
- Shrift test
- Fukui test

**31. What is stretching? (April/May2008)**

Stretching is the process of stressing the work blank beyond its elastic limit by moving form block towards the blank or sheet metal.

**32. State the methods of stretch forming process.**

- Form – block method
- Mating – die method

**33. What is meant by seaming? (April/May2008)**

The process of producing between the two edges of the different work metal is called as seaming.

**34. What are the advantages and disadvantages of peen forming process?**

**Advantages:-**

- Complex coat ours can be produced
- Penning is also used as salvage operation for correcting bent

**Disadvantage:-**

- It requires longer time for forming the required shape

It requires additional devices for forcing out metal shots.

**35. Mention the Advantages of super plastic forming. (Nov/Dec 2008, 2013)**

It is a one step process

Higher material elongation.

Elimination of necessary joints

Minimizes the amount of scarp

Reduction of subsequent machining

**36. What are the applications of forming limit diagram? (Nov/Dec 2008)**

The new set of tools in easy, hard or impossible to work can be easily determined.

Good materials used in forming operation are identified.

Location of source of trouble is also easy from a reference pressing by the designer.

**37. How work – hardening is predicted in terms of stress- strain in formability?**

Usually, the strain distribution is assessed from the surface but, the magnitude of strain is determined by impregnating the sheet metal with a grid pattern followed by pressing. During pressing the sheet metal. Concentric circles are stretched into elliptic during pressing.

**38. What is mean by standoff distance in explosive forming process(Nov/Dec-2018)**

The sheet metal work piece blank is clamped over a die and the assembly is lowered into a tank filled with water. The air in the die is pumped out. The explosive charge is placed at some predetermined distance from the work piece,



## UNIT – 4 SHEET METAL PROCESSES

### FORMABILITY OF SHEET METAL

Formability may be defined as the ease with which material may be forced into a permanent change of shape. The formability of a material depends on several factors. The important one concerns the properties of material like yield strength, strain hardening rate, and ductility. These are greatly temperature - dependent. As the temperature of material is increased, the yield strength and rate of strain hardening progressively reduce and ductility increases. The hot working of metal, therefore, permits relatively very large amount of deformation before cracking.

There are several methods of predicting formability. A brief description of some important methods follows.

#### Cup or Radial Drawing:

Cup drawing test uses a circular blank from the metal to be tested. It is inserted in a die, and the severity of the draw it is able to withstand without tearing called the drawing ratio, is noted. The drawing ratio is the ratio of the cup diameter to the blank diameter.

$$R_d = \frac{D - d}{D}$$

Where  $R_d$  = drawing ratio

$D$  = blank diameter

$d$  = punch diameter

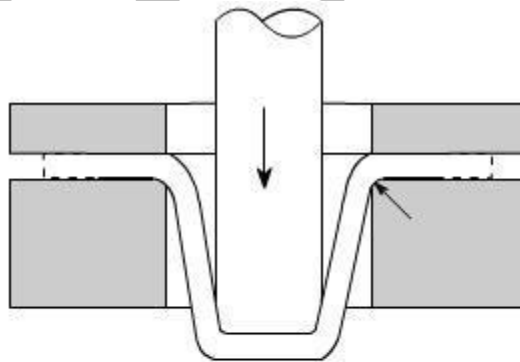


Fig .4.1 (a)

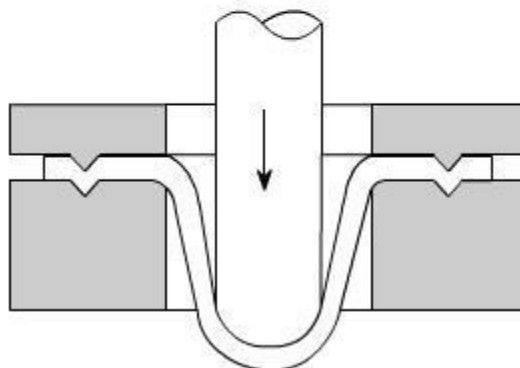


Fig .4.1 (b)

A drawing ratio of 50 % is considered excellent. As shown in [Fig 4.1\(a\)](#), either a flat bottom punch with lubricated blank may be used to draw the cup, or as shown in [Fig 4.1\(b\)](#) a blank may be drawn by a lubricated hemi – spherical punch. In the first case, the action is principally that of drawing in which cylindrical stretching of material takes place. In the second case, there will be bi – axial stretching of the material. For drawing, the clamping force is just sufficient to prevent buckling of the material at the draw radius as it enters the die. The deformation takes place in the flange and over the draw radius.

### **Fukui Conical – Cup Test:**

It utilizes a hemispherical, smoothly polished punch. No blank holder is required. In each test, a drawing ratio which will result in a broken cup is determined. Formation of wrinkles is avoided by using a fixed ratio between the thickness of the sheet, the size of the blank, and the punch and die diameters. Under these conditions, the test produces a known amount of stretching, drawing, and bending under tension.

### **Normal Anisotropy Coefficient:**

The material is subjected to uni-axial tensile test. The anisotropy coefficient is derived from the ratio of the plastic width strain  $\epsilon_w$  to the thickness strain  $\epsilon_t$ . A material with a high plastic anisotropy also has a greater “thinning resistance.” In general, the higher the anisotropy coefficient the better the material deforms in drawing operations.

### **Strain-Hardening Coefficient:**

Strain hardening refers to the fact that as a metal deforms in some area, dislocations occur in the microstructure. As these dislocations pile up, they tend to strengthen the metal against further deformation in that area. Thus the strain is spread throughout the sheet. However, at some point in the deformations, the strain suddenly localizes and necking, or localized thinning, develops. When this occurs, little further overall deformation of the sheet can be obtained without it fracturing in the necked region.

The strain – hardening coefficient therefore reflects how well the metal distributes the strain throughout the sheet, avoiding or delaying localized necking. The higher the strain – hardening coefficient, the more the material will harden as it is being stretched and the greater will be the resistance to localized necking. Necks in the metal harm surface appearance and affect structural integrity.

For many stamping operations, stretching of the metal is the critical factor and is dependent on the strain – hardening coefficient. Therefore, stampings that need much drawing should be made from metal having high average strain – hardening coefficients. Yield strength should be low to avoid wrinkles or buckling.

**1. Explain the principle of stretch forming? Explain its types.(Nov/Dec-2009)**

(OR)

**1. How curvature are made on thin sheet metals, explain the suitable process with neat sketch. (Nov/Dec 2013)**

Stretching is the process of stressing the work blank beyond its elastic limit by moving a form block towards the blank or sheet metal.

**Methods of stretch forming:**

Stretch forming can be done in two methods

- ✓ Form – block method
- ✓ Mating die method

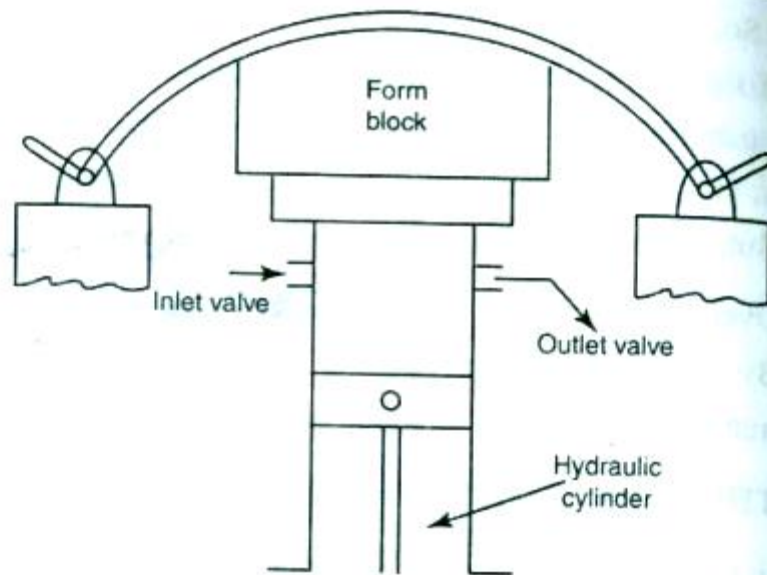
**Form – block method**

- ✓ In this method, the two ends of the blank or sheet metal is tightly held by an adjustable gripper.
- ✓ These grippers are fixed but adjustable.
- ✓ Then, the form block is moved towards the blank to make the required shape.
- ✓ In this case, the form – block is operated by hydraulic cylinder.
- ✓ When the form block moves towards the blank, the hydraulic fluid inside cylinder gets compressed and delivered through the outlet valve.
- ✓ The movement of the form always depends the hydraulic fluid pressure inside cylinder.
- ✓ The fluid is entered the cylinder when the form-block moves away from the blank after completing stretching process.
- ✓ In a single stretching process, we can get no need of stage in stretching.
- ✓ Force exerted on the piston is calculated as

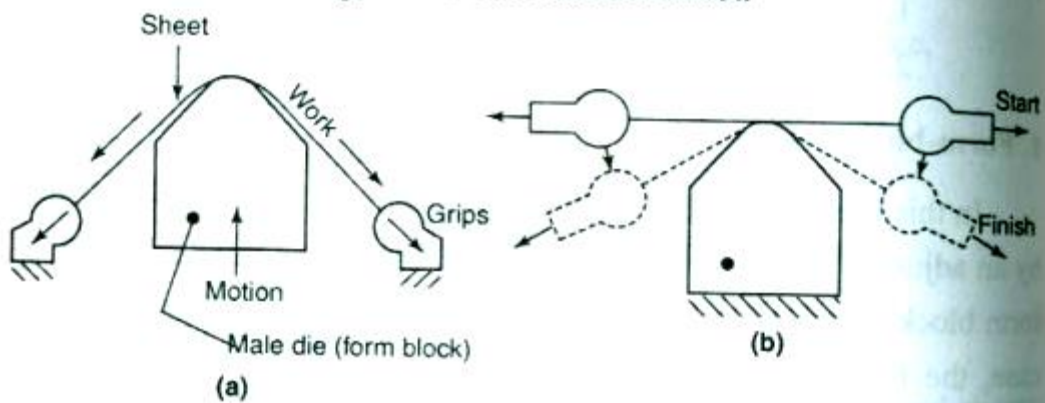
$$F = \frac{\pi}{4} d^2 p$$

P=hydraulic fluid pressure

D= diameter of the piston.



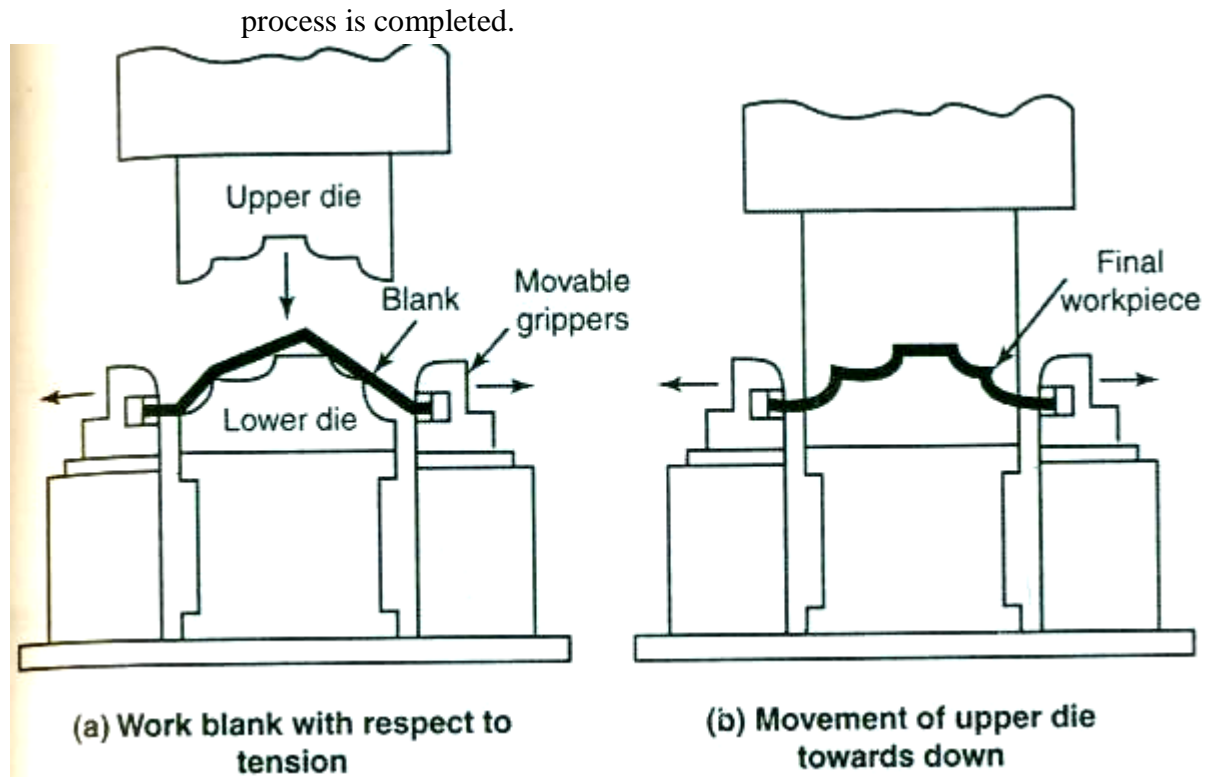
**Fig.4.32. Form-block method**



- ✓ Stretching the blank can also be done by fixing the form block stationary and working the grippers towards the form – block.
- ✓ It is performed by holding the blank ends in movable grippers.

**Mating – die method:**

- ✓ In this method, the blank is held in movable grippers.
- ✓ The blank is placed between the lower and upper die.
- ✓ The lower die is kept stationary and the upper die is movable one which is operated by hydraulic or pneumatic cylinders.
- ✓ First, the movable grippers are moved towards the lower die on which only elastic deformation takes place.
- ✓ Next, the upper die is moved towards the blank.
- ✓ When the upper die touches the blank, only elastic changes takes place.
- ✓ Due to continuous stretching of the blank by the upper die, plastic flow of sheet metal takes place between lower and upper dies.
- ✓ When the upper die edge reaches the top surface of the blank the stretching



### Materials for die and form blocks

Wood, masonite, zinc alloys, cast iron

### Advantages:-

- ❖ No need of any heat – treatment before and after the stretching process.
- ❖ Tooling costs are low.
- ❖ Direct bending is required
- ❖ Plastic deformation is due to pure tension only.
- ❖ This method is more suitable for low volume production.

### Disadvantages:-

- ❖ Maintenance cost of hydraulic cylinder is high.
- ❖ The process requires high quality form – blocks
- ❖ Blank thickness should be uniform throughout the length.
- ❖ Sudden changes in contour surface cannot be stretched.

### Limitations:-

- ❖ Uneven thickness of blank cannot be stretched.
- ❖ Stretching of blank to the required shape of contour is limited.

### Applications:-

- ❖ Production of aircraft wing & fuselage parts.
- ❖ Production of contoured panels for truck is automobile industry.

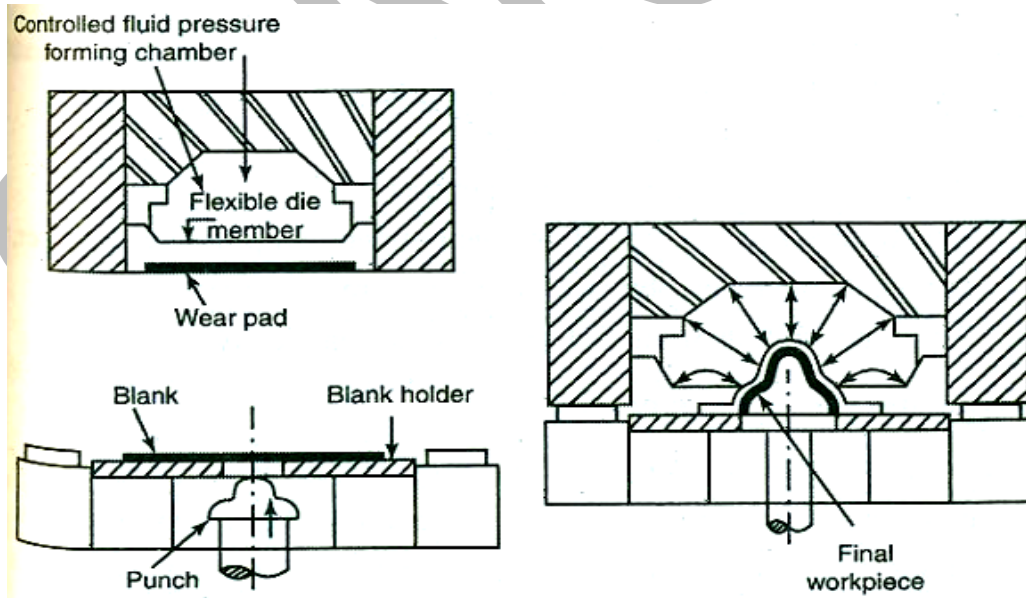
### 2. Explain the process of hydro forming. Explain the types of hydro forming. (NOV/DEC.2011)

Hydro forming is a drawing process. It is forming process is carried out is two ways.

- Hydro mechanical forming
- Electro hydraulic forming

#### 1.Hydro mechanical forming

- In this type of forming process, the punch is connected to the lower die called male die.
- The required shape of inner configuration is made on the punch.
- A rubber diaphragm or seal is used for making perfect sealing between male and female die.
- This seal is placed across the bottom of the pressure – forming chamber. The pressure – forming chamber is filled with a hydraulic fluid.
- Then, the blank is correctly positioned over the male die or lower die.
- Now, the pressure forming chamber called done is lowered over the blank is such a way that the deuce is made to just contact with the blank



- After this, hydraulic pressure is applied over the blank.
- Simultaneously, the punch is pushed into the blank.
- The pressure applied by the hydraulic fluid is increased continuously.
- Due to this, the blank metal flows around the punch to form the required

shape.

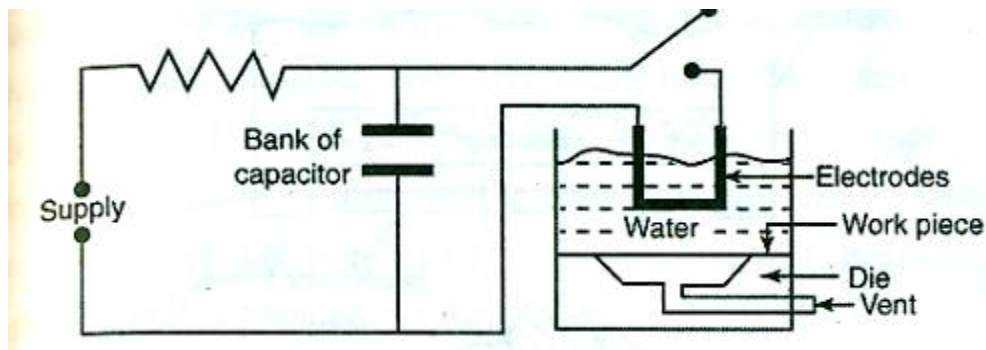
- The inverted shape of the punch is made on the blank.
- After forming the required shape, the chamber pressure is released.
- Then the chamber is raised from the blank.
- Finally the blank is obtained stripped out from the punch.
- In this case, the required shapes of the blank are obtained only by drawing rather than by bending.
- And also, the blank metal is displaced due to plastic flow instead of stretching

**Advantages:-**

- Complicated contours can also be made.
- Thinning of metal, spot stresses and spring back are drastically reduced or completely eliminated.
- It is used for mass production because work performed per operation is high.
- Tool changing can be done rapidly.
- Sharp corners are also possible.
- All types of sheet metals can be handled.
- Tolerance of 0.005mm/mm are possible practically.

**2. Electro hydraulic forming process.**

- The working principle of metal forming process is same as that of hydro mechanical forming process.
- But, the applied pressure over the blank differs.
- Because the pressure inside the pressure forming chamber is produced by electrical means.
- The arrangement of this electro hydraulic forming system is shown in fig .
- When the supply is given to electrical circuit, a high energy is discharged through a bank of capacitor to the hydraulic fluid contained to be the chamber.
- The discharged energy in the chamber is in the form of shock waves and pressure.
- This mechanical energy is used for metal forming operations in the same manner as mentioned in hydro mechanical forming operations.



**Advantages:-**

- The pressure inside the chamber is high due to combined shock wave & fluid pressure.
- Time required per operation is low when compared to hydro mechanical forming operations.

**Disadvantages:-**

- Energy losses occur between electrical components to hydraulic fluid.
- Stagnation properties refer to the properties at zero velocity.
- Due to shock waves drag force is created and finally it results stagnation pressure in the fluid.

**3. Explain the principle of metal spinning process with a neat sketch. (NOV/DEC.2011)**

The process of forming seamless metal parts from a circular sheet metal or from a tube length on a lathe is called as spinning process.

Only symmetrical shapes can be produced from metal spinning process.

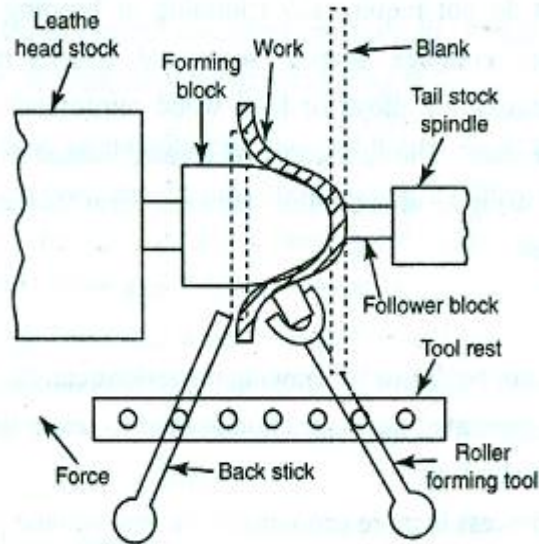
**Methods of spinning process:-**

There are two methods used to produce sheet metal parts.

- Manual spinning
- Power spinning

**Manual spinning:-**





First, the circular blank is centered on a lathe which is placed against a form block. The form block is mounted on the head stock of the spinning lathe. The blank is tightly held between form block and tail stock spindle. The required contour surface is made on the form block.

The pressure is applied by the roller type forming tool which is placed on the tool post of the spinning lathe. The required shape is gradually formed by continuous application of pressure by the roller. During spinning process, some stretching and thinning of material takes place.

Metal spinning can be done both in add and hot state. Heat generation due to friction between spinning tool or roller type forming and blank can also be used to retain the plastic state of sheet metal. Spinning speed varies with size, design, type of metal and thickness of sheet metal.

Aluminum copper, brass and stainless steel can also be spun in spinning process.

This process is mainly stainless suitable for producing conical shape parts. And suitable for low volume production. Components produced in this process do not require any trimming or beading operations. For producing more complex shapes, segmental chucks made from cast aluminium, magnesium alloys or hard wood reinforced with cold rolled steel sheets are used. The lubricants of grease, linseed oil and bees wax are used while using bead and tallow between form tool and blanks during spinning process.

#### **Advantages:**

- ❖ Parts not be drawn by drawing operations can be easily spun.
- ❖ Heat generated due to friction is used to retain the sheet metal in the plastic state.
- ❖ The process is more economical for low volume production.

#### **Disadvantages:**

- ❖ Thinning takes place during spinning process.
- ❖ More complex shapes require segmental chucks. Finally, it leads to increase in cost.
- ❖ Accuracy and quality of finished products mainly depends on the skill of the operator.

## 2. power spinning process:-

The quality of finished products mainly depends on the skill and experience of the operator. Accuracy of the finished products is also less in manual spinning process. Even though segmental chucks are used for making complex shapes, the metal thickness and contour shapes are restricted in manual spinning. In order to ensure skill of the operator and reduced machining time, spinning machines are used referred as power spinning.

In power spinning process, the action of form tool is controlled either by any tracer mechanism or by numerical controls. Nowadays computer controlled numerical machines are used to change the shape of contour whenever we want from the existing program.

HMT lathe is a semiautomatic spinning and flow turning machine with a hydraulic copying attachment. The spinning of sheet metal is done automatically, but the loading and unloading of sheet metal are done manually. This HMT lathe also consists of headstock, tail stock and slides mounted on the bed. Tailstock is operated hydraulically. The blank is held between the tailstock and the form block. Then, the roller is pressured over the blank to obtain the required shape. In one pass or in successive passes of roller the required shape is formed.

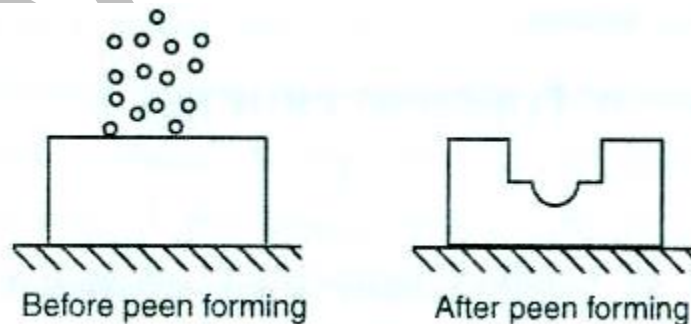
### Advantages:-

- ❖ Accuracy and quality can be maintained.
- ❖ It is suitable for high volume production
- ❖ Time taken to spin the sheet metal is greatly reduced

**Application:-**production of missile, radar units, jet plane components tanks, air conditioning units and heating plants.

## 4. Explain peen forming process with a neat sketch. (April/May-2008)

Peen forming is a process of well – established surface cleaning. In this process, a stream of metal shots is blasted against the surface of the blank to be made into required shape.



This technique is also known as free-forming technique. A stream of small steel ball is suddenly forced with very high velocity against the surface of the blank. This process is used to form various irregular contour surfaces of aluminum **Sheet and plates**.

The length of the contour of the blank to be formed may be larger. Even the required shape can be obtained by planning the blank on a table or by suspending from a support to blast.

According to the direct shape of contour, the sheet metal or blank is clamped over from blanks during penning operation. The peen- formed parts are checked by using templates.

**Advantages:-**

- Complex contours can be produced easily
- This process does not require any die and punch
- Peening is also used salvages operation for correcting bent or distorted parts.

**Disadvantages:-**

- It requires longer time for forming the required shape.
- It requires additional devices for forcing out metal shots.

**Application :**

- This process is used in producing specific portion on crankshafts, connecting rods and gears.
- It is used for producing honeycomb panels like aircraft wings and large tubular shapes.

**5. List out the sheet metal characteristics. (Nov/Dec-2008)**

**Roll forming:-**

Long parts with content complex cross section, good surface finish, high production rates, and high tooling costs are produced.

**Stretch forming:-**

Large parts with shallow contours suitable for low- quality production, high labor costs, tooling and requirements costs depend on part size are produced.

**Drawing:-**

Shallow or deep parts with relatively simple shape, high production rates, and high tooling and equipment costs are produced.

**Stamping:-**

It includes a veracity of operations, such as punching, blanking, and embossing bending, hanging and coining, simple or complex shape are formed at high production rates, tooling and equipment costs can be high, but labour cost is low.

**Rubber forming:-**

It includes drawing and embossing of simple or complex shapes, sheet surfaces protected by rubber membranes, flexibility of operation, low tooling costs.

**Spinning:-**

Small and large ax symmetric parts, good surface finish, low tooling cost , but labor cost can be high unless operations are automated.

**Super plastic forming:-**

Complex shapes, fine detail and close tolerance, forming times are long. Hence production rate is low. So, parts are not suitable for high temperature use.

**Peen forming:-**

Shallow contour on large sheets, flexibility of operation, equipment costs can be high,process is also used for straightening parts.

### Explosive forming:-

Very large sheets with relatively complex shapes, although usually axisymmetric, low tooling costs, but high labor cost, suitable for low-quantity production, long cycle time are produced.

### Magnetic pulse forming:-

Shallow forming, bulging and embossing operations on relatively low strength sheets, most suitable for tubular shapes, high production rates, require special tooling.

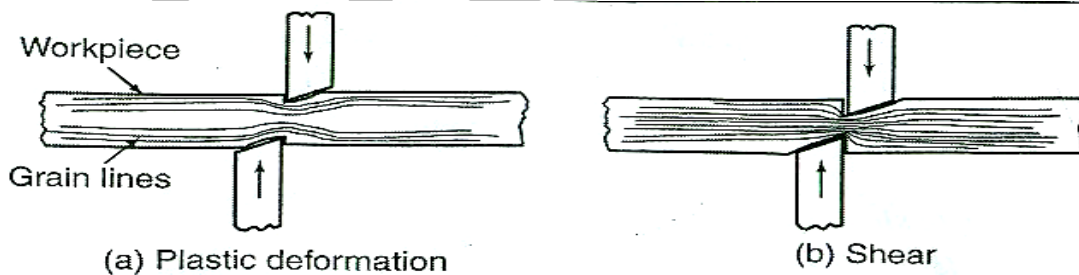
### 6.(i) Enumerate with neat sketches three phase in shearing. (APRIL/MAY 2010)

The process of cutting a straight line across a strip, sheet or bar is known as shearing process. This action has three important basic stages.

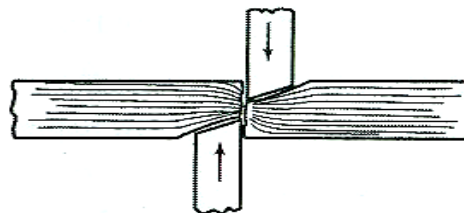
1. Plastic deformation
2. Shear and
3. Fracture

Fig shows the four stages of the shearing process:

**a) Plastic deformation:** The blades begin to apply pressure, the workpiece start to undergo elastic deformation. As pressure increases the workpiece undergoes plastic deformation.



(b) Shear



**b) Shear:** The blades begin to penetrate either side which produces shear of workpiece along a vertical line. Work hardening occurs in the centre.

**c) Fracture:** Fracture lines originating from the point of each blade meet in the centre of the workpiece causing separation before the blades have fully penetrated.

To reduce the pressure of burrs it is important that the blades are sharp. Also it is important that they do not deflect under pressure and that they are not set too far apart (offset), if this happens the fracture lines may not meet cleanly and the material will be dragged down the gap between the blades.

**(ii) What are various bending operations? Explain any four. (APRIL/MAY 2010)**

There are different types of bending operation as follows:

1. Angle bending
2. Roll bending
3. Roll forming and
4. Seaming

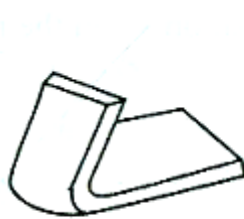
**1.Angle bending**

In this case, the metal is bent at an angle to each edges. It is denoted by " $\theta$ ".

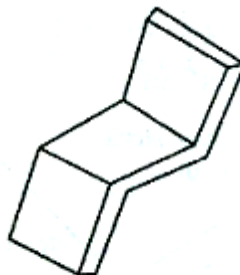
If  $\theta < 90^\circ$  on side, it is called as single bending.

If  $\theta = 90^\circ$ , this is called as vertical or straight bending.

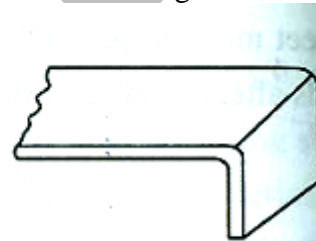
If  $\theta < 90^\circ$  but in two places on the same work, it is called as double bending.



Single bend



Double bend



Straight flange

**2.Roll bending**

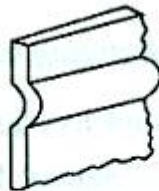
If the metal is bent in the form of rolled edge at the edges of the work, it is called as roll bending.



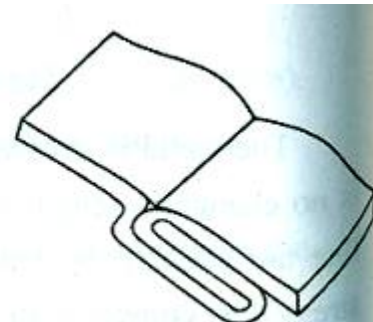
Curling or wiring



Embossing



Enlarged section



Double hem or lockseam

**3.Roll forming**

If the edges are formed to a desired shape or any impression in the form of bend is made on

the sheet metal, it is called as roll forming operations.

#### 4. Seaming

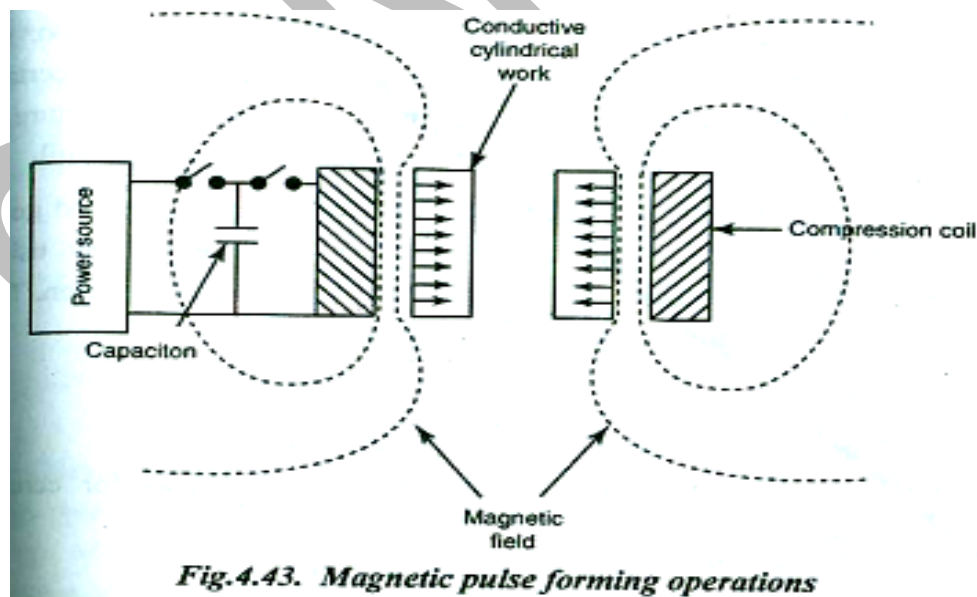
The process of providing lock between the two edges of the different work metal is called as seaming. To perform this, the edges of sheet metal to be locked is bent in opposite direction to each other. Then they are inserted with each other and pressed or tightened to make complete lock.

#### 7. Write short notes on (APRIL/MAY 2010)

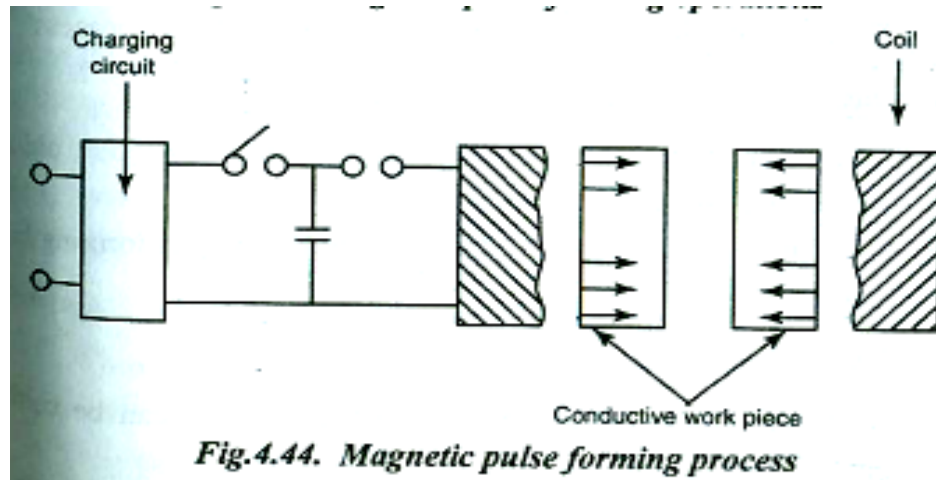
##### (i) Hydro forming (refer question no.2)

##### (ii) Magnetic pulse forming

- The required shape of sheet metal is obtained by specially designed magnetic coil.
- The basic principle is that discharged of a capacitor through a coil over a period of microseconds, on the blank to obtain the required shape.
- During this, the magnetic flux densities of the order of hundreds of kilogauss can be produced.
- The basic circuit consists an energy storage capacitor, a switch, a coil and a power source. The current through the coil produces a high intensity magnetic field between the coil and the work piece.
- Due to the eddy current in the blank, the magnetic field is restricted over the surface of blank.



*Fig.4.43. Magnetic pulse forming operations*



**Fig.4.44. Magnetic pulse forming process**

- Due to the interaction of eddy current on the blank, the applied magnetic field creates an inward force on the work piece.
- The repelling force between work piece and the coil is high. Since, the coil is placed rigidly. So, the blank is repelled and forced against a coil.
- Property designed coils can be used for compression, expansion or for forming the blank to concentrate the current.
- Hence, the force in certain regions of the blank is shaped by utilizing massive conducting structure as flux concentrator device and not connecting it directly to the basic coil.
- This process is most suitable for copper, aluminium, silver and gold.
- For non-conducting material, the force must be generated by using conductive material between the coil and blank for efficient operation.
- The coil should be good and perfectly fit in the blank.

### **Advantages**

1. This process is carried out with uniform rate of forming.
2. It is also better process than convention process for certain materials.
3. The surface finish of the process is excellent.
4. Time of operation is less as compared to conventional process.

### **Disadvantages**

1. Non – conducting materials are not processed without aid of conducting materials
2. It is limited for sheet metal forming process not an forming bulk material.

### **Applications**

1. Both compression and expansion of circular bar can be carried out.
2. Producing bulging of tube, shrinkage of tube, attaching tubes at end fitting without leaking are possible.
3. Forming a torque joints, forging of structural joints between tubes are fitting are easily



formed.

4. It is used for instrument gear assembly, embossing and sizing of cups etc.,

### **(iii) Super plastic forming. (APRIL/MAY 2010)**

#### **Introduction**

- Manufacturing of complex lightweight automotive structures that meet cost and product goals is a competitive challenge facing industry.
- Super plastic forming (SPF) is a valuable tool for the fabrication of complex parts used in the aircraft and automobile industries.
- Super plastic forming (SPF) of sheet metal has been used to produce very complex shapes and integrated structures that are often lighter and stronger than the assemblies they replace.
- Superplasticity in metals is defined by very high tensile elongation, ranging from two hundred to several thousand percent.
- Superplasticity is the ability of certain materials to undergo extreme elongation at the proper temperature and strain rate.
- ❖ The process typically conducted at high temperature and under controlled strain rate, can give a ten-fold increase in elongation compared to conventional room temperature process.
- ❖ Components are formed by applying gas pressure between one or more sheets and a die surface, causing the sheets to stretch and fill the die cavity.
- ❖ The evolution of pressures must be closely controlled during the process since the alloys of interest only exhibits super plastic behavior for certain temperature dependent range of strain rates.
- ❖ Specific alloys of titanium, stainless steel, and aluminium are commercially available with the fine-grained microstructure and strain rate sensitivity of flow stress that are necessary for super plastic deformation.

#### **Process**

- SPF can produce parts that are impossible to form using conventional techniques. During the SPF process, the material is heated to the SPF temperature within a sealed die.
- Inert gas pressure is then applied, at a controlled rate forcing the material to take shape of the die pattern.
- The flow stress of the material during deformation increase rapidly with increasing strain rate. Super plastic alloys can be stretched at higher temperature by several times of their initial length without breaking.

Some of the materials developed for super plastic forming are;

1. Bismuth-tin (200% elongation)
2. Zinc-aluminium

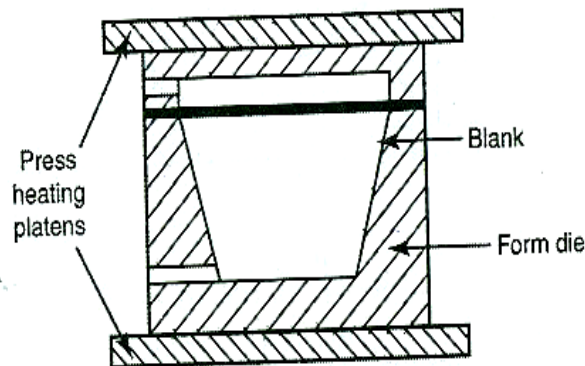


3. Titanium (Ti-6Al-V)
4. Aluminium-lithium alloys (2090,2091,8090)

### Super-Plastic Forming-Process

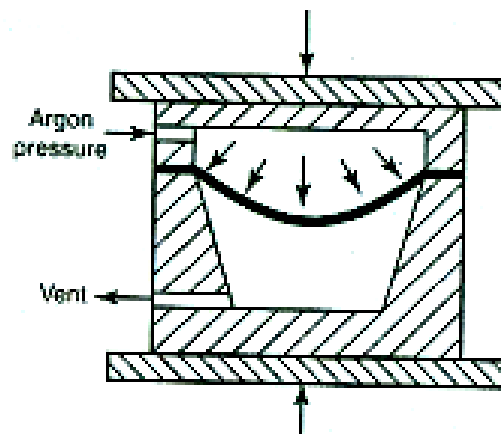
This method consists in hot forming up to 1000°C super plastic alloys by using an inert gas pressured up to 50 bars. Combined with diffusion bonding, this process allows honeycomb structures made of several sheets in a single operation.

#### Loading:



The blank is loaded in the form die. The hot press heats the die and the blank to the material super-plastic temperature.

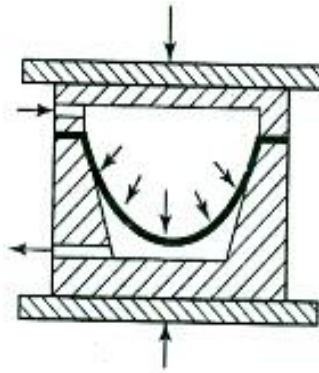
#### Forming:



Once the temperature is reached, it is accurately controlled, while the gas pressure slowly inflates the blank.

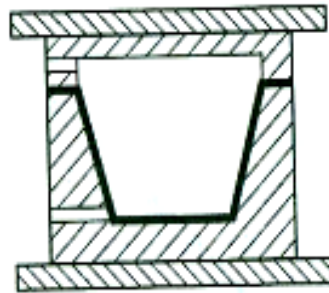
#### Forming:

The gas keeps inflating the part to fit the die. The material at the super-plastic temperature can allow up to 500% elongation.



**Release:**

At the end of the forming cycle, the part perfectly conforms to the die, even in its smallest details.



**Advantages of SPF process**

Super plastic forming technology offers the potential to reduce the weight and cost of automotive structural components for advance vehicle application.

The main advantages of this process are:

1. It is a one step process
2. The process can be used to form complex components in shapes that are very near the final dimension
3. Higher material elongation.
4. Elimination of unnecessary joints and rivets.
5. Reduction of subsequent machining.
6. Minimizes the amount of scrap produced.

**Application.**

The process is increasingly being applied in the aerospace industry as a way of manufacturing very complex geometries

- (i) In automotive body component
- (ii) In forming of aircraft frames and skins.

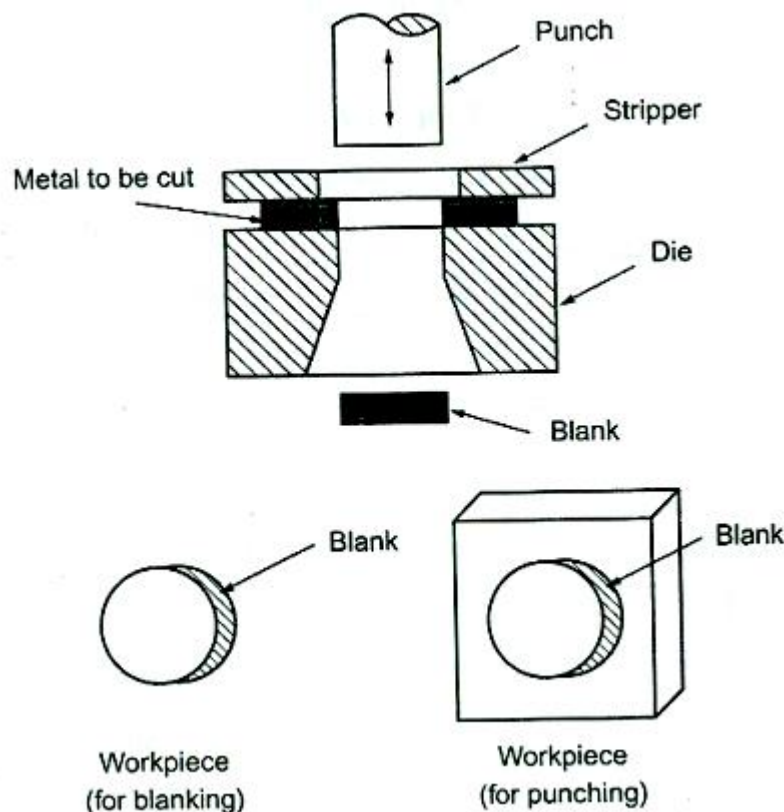
(iii) Diaphragm forming of plastics.

(iv) Complex shape parts-window frames, seat structures.

**8.(i) Distinguish between blanking and punching operations. Sketch and explain the elastic phase, plastic phase and fracture phase that take place in a blanking operation. (NOV/DEC.2011)**

### 1. Blanking

Blanking is the operation of cutting a flat shape from the sheet metal. The metal that is punched out is called as “blank” and the metal that is left out is called as scrap.



### 2. Punching

It is the operation of producing the hole on the workpiece by a punch. In punching, the metal removed is called as scrap, and the metal that is left out called as workpiece.

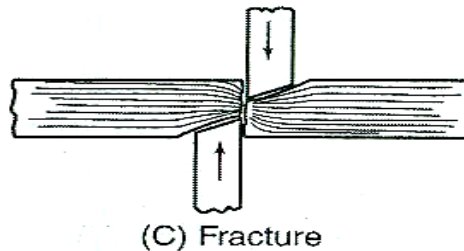
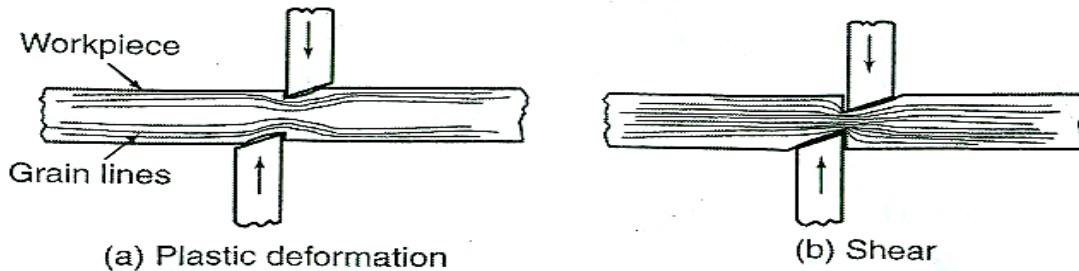
The process of cutting a straight line across a strip, sheet or bar is known as shearing process. This action has three important basic stages.

1. Plastic deformation
2. Shear and

### 3. Fracture

Fig shows the four stages of the shearing process:

**a) Plastic deformation:** The blades begin to apply pressure, the workpiece start to undergo elastic deformation. As pressure increases the workpiece undergoes plastic deformation.



**b) Shear:** The blades begin to penetrate either side which produces shear of workpiece along a vertical line. Work hardening occurs in the centre.

**c) Fracture:** Fracture lines originating from the point of each blade meet in the centre of the workpiece causing separation before the blades have fully penetrated.

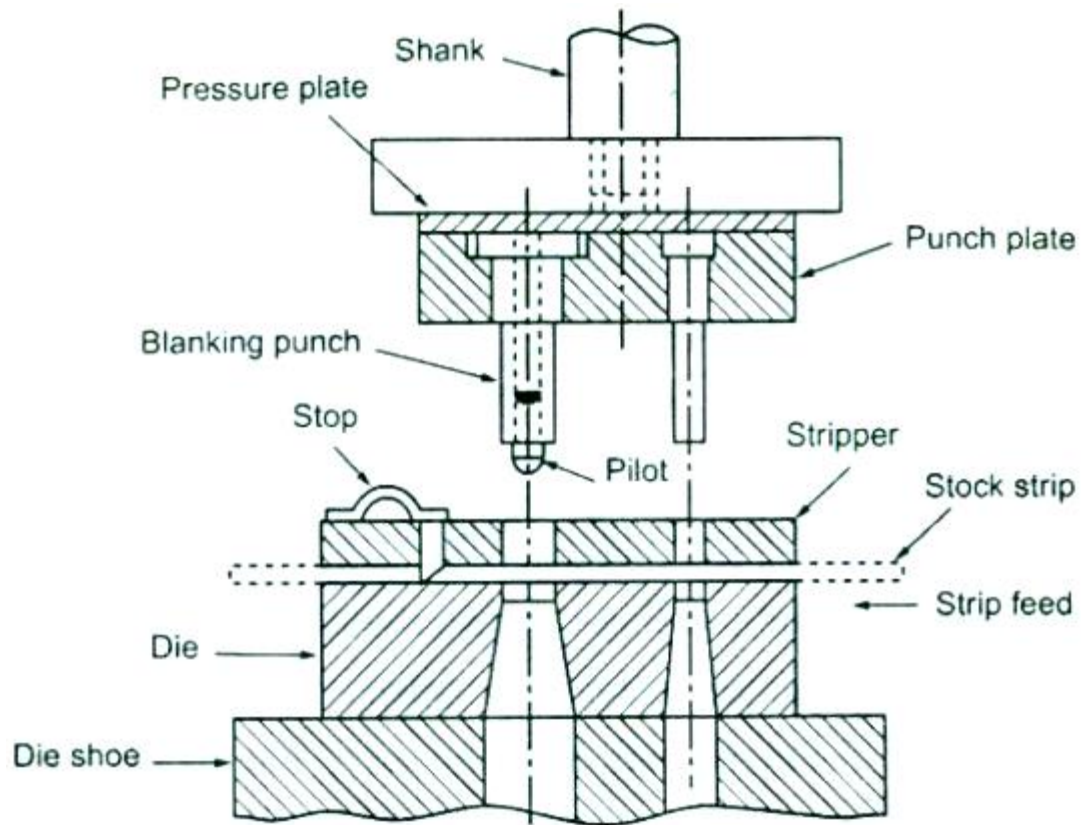
To reduce the pressure of burrs it is important that the blades are sharp. Also it is important that they do not deflect under pressure and that they are not set too far apart (offset), if this happens the fracture lines may not meet cleanly and the material will be dragged down the gap between the blades.

**(ii) Briefly explain what are compound die and progressive dies, with suitable sketches. (NOV/DEC.2011)**

#### **Progressive dies**

These dies are designed to perform two or more operations at different stages every time when the ram descends. The stock strip is advanced through a series of stations that perform one or more distinct die operations on the workpiece. The strip must cover from the first through each succeeding station to produce a complete workpiece. After that, a complete workpiece is produced with each stroke of the ram.

Figure shows a progressive die to carryout piercing and blanking operations. The stock strip is fed into the die mechanically or by hand. The primary stop is pushed-in by hand to hold against the lead end of the sheet metal. The primary die stop is drawn back after the hole is pierced. The hole is pierced by the piercing die set in the first cutting stroke of the ram.



After the primary die stop is released, the stock advances to the next station where it contacts the automatic button die stop. The correct spacing is obtained by the help of the secondary stop pin.

In the second cutting stroke of the ram, the pilot of the blanking punch enters the pierced hole and ensures exact alignment of the stock as the part is blanked.

At the same time, the blanking punch descends and shears the metal to form a washer. While the blanking operation is performed, the piercing punch produces a hole for the next washer at the first station. Thus, after the first stroke, when only a hole will be punched, each stroke of the press produces a finished washer.

A progressive die is also known as cut-carry die. It is a multi-station die that performs several operations in a single stroke of the ram in a press. Example, piercing operation is carried out in one station and it is further progressed to next station to perform blanking operation. At the same

time, next piercing operation will be performed for the second washer while blanking the first washer.

Progressive dies are often made with many stations. When establishing the sequence of operation for progressive dies, punching operations must be placed first. Operations that required bending and forming must be done in the later stations. Necessary care must be taken to avoid pierced holes too close to a bend.

The blanking and piercing punches should not be same height. A stepping is given in order to reduce the forces. For piercing operations, the punch will have the shear and the die will be flat. For blanking operation, the punch will be flat and shear is given to the die.

### **Advantages**

- (i) The number of operations can be performed with one handling of the stock strip.
- (ii) For every stroke of the ram, one workpiece is made.
- (iii) It is fairly simple to construct and are economical to repair.
- (iv) It is suitable for mass production.

### **Disadvantages**

- (i) Thin stock of shaft materials may cause trouble by bending or tearing around piloting holes.
- (ii) Workpiece may become dished as they are pushed through the die since they have a little support.
- (iii) It is complicated design of die set as compared with simple dies.
- (iv) The cost of the die set is high when compared to simple die set.

### **Compound dies:**

In a compound die, two or more cutting operation, such as blanking, such as blanking, piercing operations are combined and carried out in one stroke of the press at one station only. In order to do this, both the upper and lower elements which are directly opposed to each other. In other words, the piercing punch acts in the opposite direction with respect to the blanking punch.

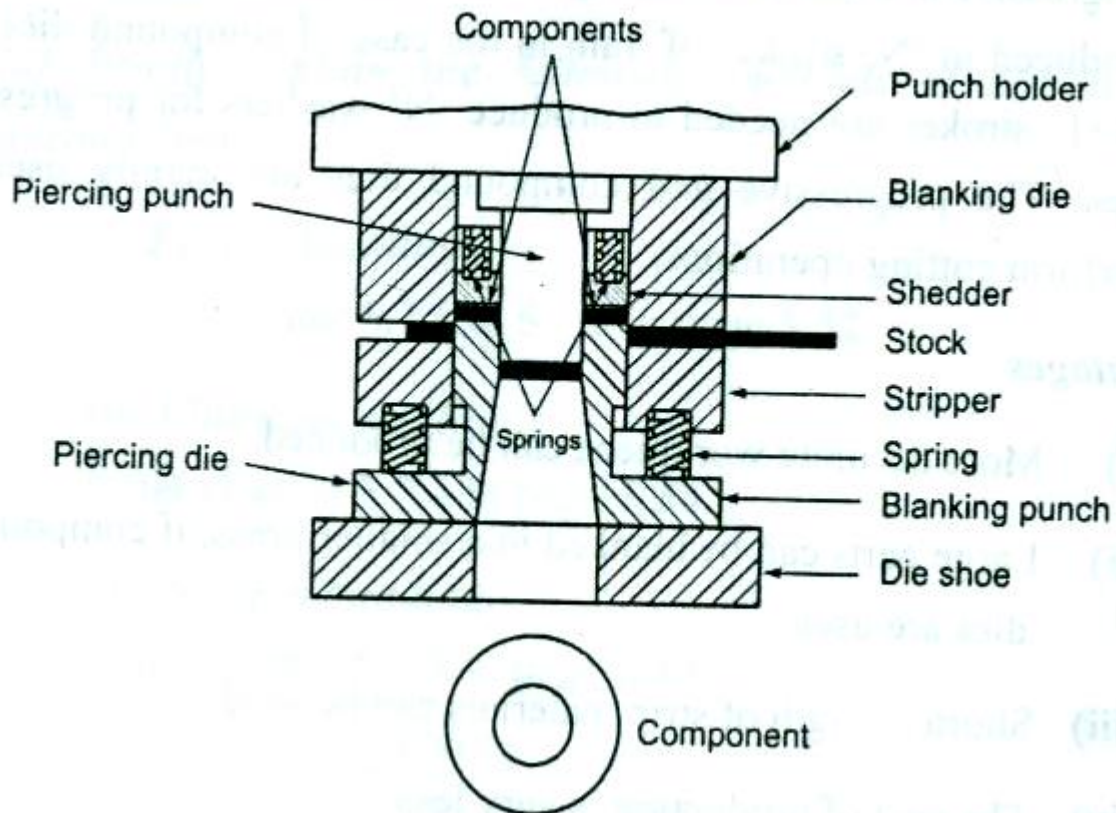


Figure shows a simple compound die. It is used for producing a workpiece (washer) which is pierced and blanked at one station and in one operation. Here, the blanking punch also serves as the piercing die.

The blanking punch and blanking die opening are mounted in an inverted position. The sidewalls adjacent to the cutting edges of the blanking die opening are straight because the blank does not pass through the die. During the part of the stroke, piercing of hole is done on the stock and upon further travel, the blanking operation is done. Angular clearance must be provided in the piercing die to allow slugs to drop through the die.

Compound dies are designed in such a way to carry out both the piercing and blanking operations at the same in a single stroke of ram. The workpiece will not be progressed to the next stations. Example, blanking and piercing operations are combinedly carried out in a single stroke of the ram. The main different between progressive and compound dies is, "N" numbers of washers can be produced in "N" stroke of ram in the case of compound dies but "N+1" stroke are needed to produce "N" washers for progressive dies. The progressive and compound dies are mainly used to perform cutting operations.



**Advantages:**

- (i) More accurate workpiece can be produced.
- (ii) Large parts can be blanked in a smaller press, if compound dies are used.
- (iii) Shorter length of strip materials can be used.
- (iv) The cost of producing is very less.

**Disadvantages :**

- (i) It is more expensive to construct and repair.
- (ii) It is slower in operation as compared with progressive dies.
- (iii) It is complicated design of the die set when compared to progressive dies.
- (iv) The tonnage requirement is high.

**9.(i) Describe the metal spinning process with a neat sketch and state its advantages and specific uses. (NOV/DEC.2011) (REFER Q.NO:3)**

**(ii) Explain the hydro forming process with neat sketches. Make a brief comparison of this process with conventional deep drawing. (NOV/DEC.2011) (REFER Q.NO:2)**

**10. Explain the principle of stretch forming? Explain its types.[MAY/JUNE-2013] (REFER Q.NO:1)**

**11. Explain the principle of metal spinning process with a neat sketch. .[MAY/JUNE-2013] (REFER Q.NO:3)**

**12. With a neat diagram, explain the principle of explosive forming.[NOV/DEC-2012, 2013]**

Explosive forming process is used for blanking, cutting, expanding, coining, embossing, flanging, powder compacting, drawing and sizing operations etc.

**Explosives** are used in various forms such as rod, sheet granules, liquid, stick etc. According to the placement of explosive, the operations can be divided into two categories.

- 1. Stand off operations.
- 2. Contact operations.

**1. Stand off operations**

In this case, the explosive charge is located at some distance away from the blank and its energy is transmitted through some fluid medium such as water. This technique is used to form blanks into various shapes except welding, hardening, compacting, cutting process.

**2. Contact operations**

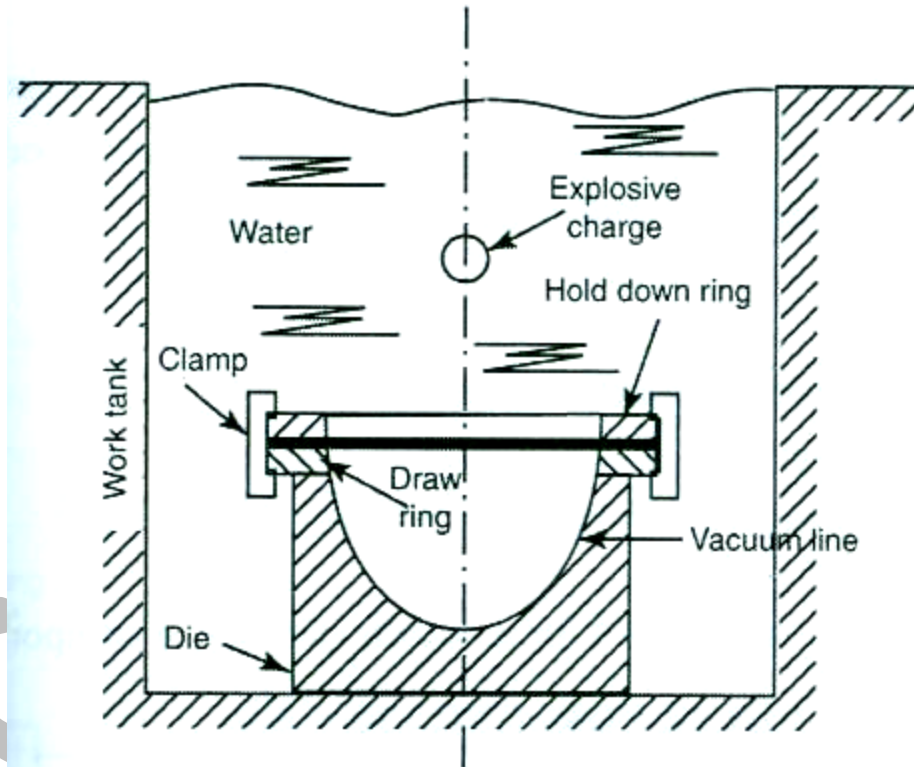
In this case, the explosive charge is directly located over the blank. This operation is mainly used for welding, hardening, compacting and cutting process.

So, the sheet metal is formed in stand off operation method. In this process, the forming of sheet metal is done by generating pressure wave in a fluid. The pressure wave is generated by detonating the enough quantity of explosives. The blank being formed is placed against the



female die. This female die has the required configurations. This entire setup of female die and blank is placed inside the work tank. The work tank contains water to receive vibrations in the form of pressure wave.

Then one same conduit is filled with charge or explosives which is also placed inside the work tank. The work tank should be perfectly insulated to avoid heat transfer from system to surrounding. Now, the explosive charge is ignited by the detonator. Due to this a high pressure energy is released in the form of waves and pulse (vibration) on the water contained in the work tank. This pressure waves are applied over the blank to obtain the required shape of female die. The applied pressure by this process may vary from several hundred to thousands of  $\text{Kg/cm}^2$  with several hundred m/s displacement velocity.



At any given distance from the explosive charge center, the high intensity portion of the pressure pulse generated by the detonating explosive, can be approximately represent as,

$$P = P_m e^{-t/\theta}$$

Where, P is Pressure as a function of time.

$P_m$  is peak pressure at that distance

t is the time after arrival of pressure front at the blank surface.

$\theta$  is time constant characteristic of the charge weight, type of explosive and distance from the charge.

**Advantages:**

- ❖ Less capital investment.
- ❖ Presses are not required
- ❖ Only one die is enough to form the sheet metal.
- ❖ Required shapes of components are formed in one stroke.
- ❖ Large and complex shapes can also be handled.

**Disadvantages:**

- ❖ Highly trained operators are needed.
- ❖ Noisy operation.

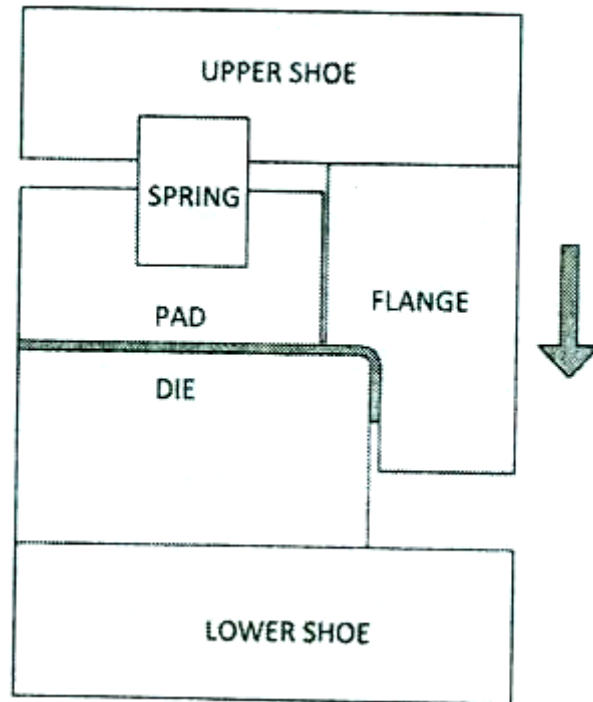
**Applications:**

This process is mainly used for producing aerospace components.

**13. Describe with illustrative sketches, the following sheet metal operations: [MAY/JUNE-2012]**

**a. Bending edge of a sheet using wiping die**

Wiping die bending, also known as edge bending is performed by holding the sheet between a pad and die then sliding the wiping flange across the face pushing and bending the sheet metal which protrudes from the pad and die. The flange is driven by an upper shoe and the die is supported by a lower shoe. A spring between the pad and upper shoe grabs the metal before the flange hits it and holds the workpiece down during the bending process. If the flange has a feature associated with it, other than just a straight bend then a stronger spring will help prevent the metal from being pulled from the area between the die and pad. This will lead to less deformation when the piece comes out of the stamp.



**b. Roll bending (REFER Q.NO:6)**

**c. Stretch forming (REFER Q.NO:1)**

**d. Deep drawing**

The process, which is used to draw the cup shaped parts from the metal, is called **deep drawing**.

The working principle of this process is that the metal blank is initially heated to a plastic state and placed on the die or cavity.

Then the forces are given by using the punch, so the required shape of cup according to the shape of cavity is produces. This process is continuous process for making smaller size cups.

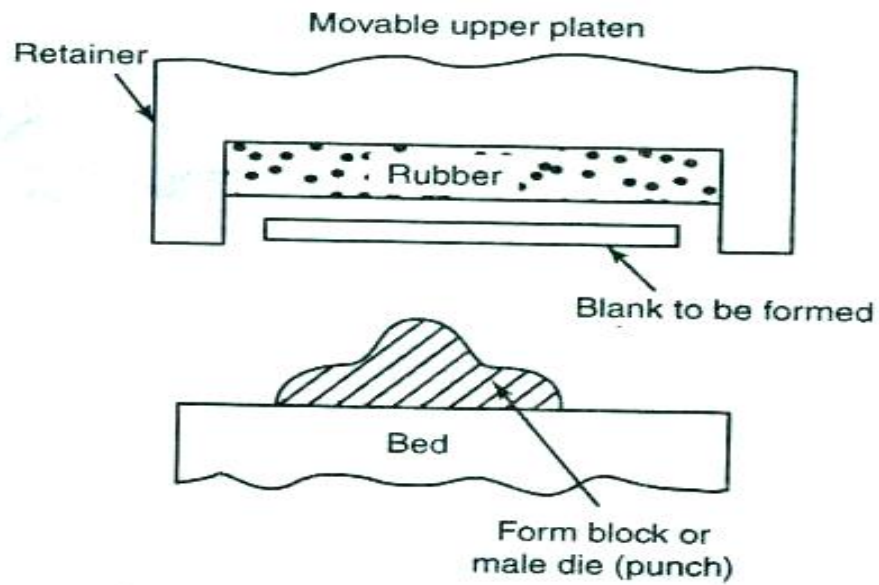
**14.Explain with a neat sketch the principle and operation of magnetic pulse forming?[MAY/JUNE-2013] (REFER Q.NO:7)**

**15.Discuss superplastic forming with neat sketches.[MAY-2013] (REFER Q.NO:7)**

**16.With a neat sketch explain the rubber pad forming process.[MAY-2012]**

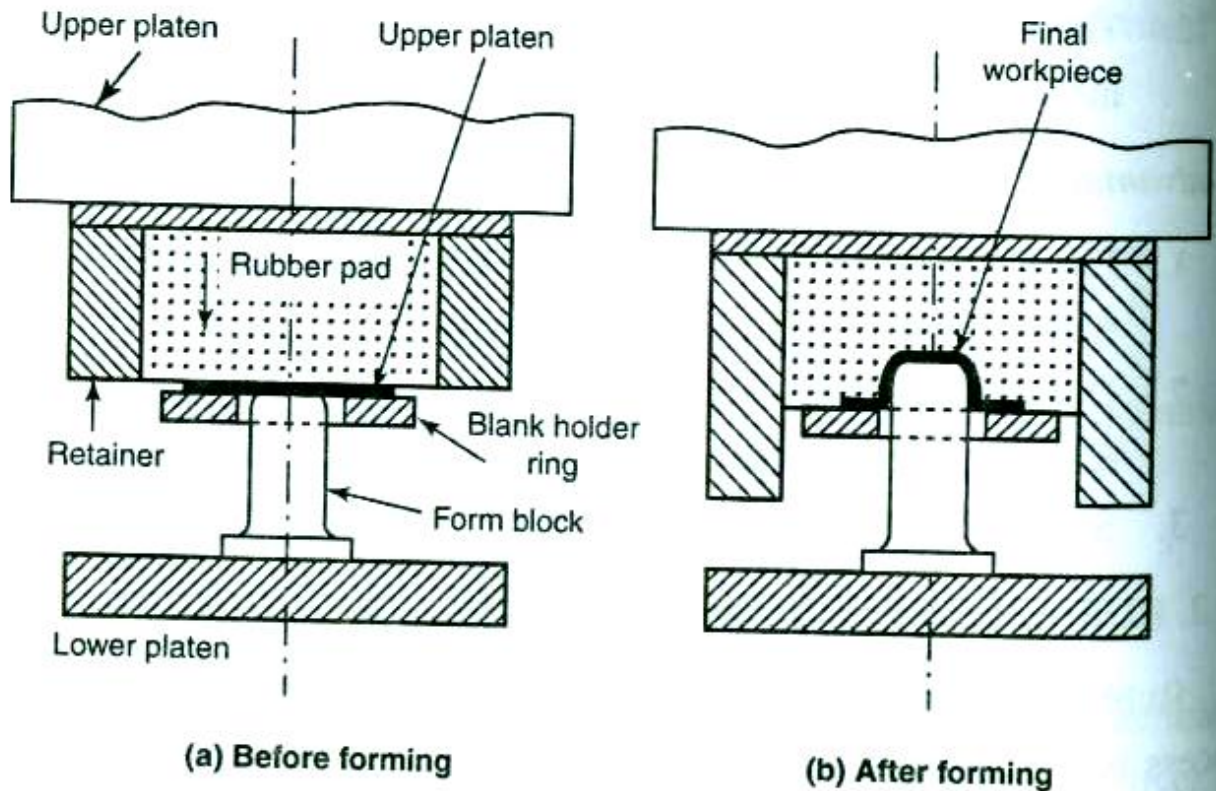
Rubber pad forming process is also called as marform process. This process is mainly used for bending and stretching or drawing operations. This process is also preferred for quantities of different shaped machine parts needed at regular intervals. For this number of

different form blocks called punches are arranged at regular intervals along the pressing bed called rubber pad.



**Fig.4.38. Rubber-press forming**

SAM



**Fig.4.39. Tooling and set-up for the marform process**

The pad is made of rubber or polyurethane. This rubber pad is placed in a ram of a press. The force applied on the blank by hydraulic cylinder through the ram and rubber pad.

First the blank is placed over the punch called male die. Then the upper pattern called female part is moved to just touch the top surface of the work. After this, the force is applied and gradually increased on the blank through the rubber pad. The blank holder ring is used to distribute uniform pressure throughout the blank. Thus the required shape is formed on the sheet metal between male and female parts. The retainers are placed on both sides of the rubber pad. The function of retainer is to apply essential hydrostatic pressure on the blank and prevents sideward motion. Then the rubber pad is released by moving the ram upwards. Now, the completed shell is stripped out from the punch.

**Advantages:**

- ❖ Process is more economical.
- ❖ Tooling cost is less.
- ❖ No need of lubricants.
- ❖ No thinning metal blank takes place.
- ❖ Tool setting time is less.

- ❖ Deeper shells can be drawn.

**Limitations:**

- ❖ Rubber pads will wear out rapidly.
- ❖ Sharp corners cannot be made accurately.

**Applications:**

- ❖ Production of flanged cylindrical and rectangular cups
- ❖ Production of spherical domes.
- ❖ Production of parallel & tapered wall shells.
- ❖ Production of unsymmetrical shape components

**17. (a) sketch explain the following sheet metal bending operation:(NOV/DEC 2012)**

**(i) Sheet bending using V-die(REFER Q.NO:6)**

**(ii) Bending edge of a sheet using wiping-die(REFER Q.NO:13)**

**(iii) Roll bending(REFER Q.NO:6)**

**(iv)Bending a sheet to a round shape using four-slide machine. (REFER Q.NO:6)**

**18.Describe forming limit diagram. (Nov/Dec 2013)**

An important development in testing the formability of sheet metals is the **forming-Limit-diagram (FLD)**. The sheet is marked with a grid pattern of circles, typically 2.5 to 5 mm (0.1 to 0.2 in.) in diameter, using electrochemical or photoprinting techniques. The blank is then stretched over a punch, and the deformation of the circles is observed and measured in regions where failure (necking and rearing) has occurred. For improved accuracy of measurement, the circles are made as small as practicable.

In order to develop unequal stretching, as in actual sheet-forming operations. The specimens are cut to varying widths (Fig. a). Note that a square specimen (farthest right in the figure) produces **equal biaxial stretching** (such as that achieved in blowing up a spherical balloon). Whereas a narrow specimen (farthest left in the figure) approaches a state of uniaxial stretching (simple tension). After a series of such tests is performed on a particular sheet metal at different widths, a forming-limit diagram showing the boundaries between failure and safe regions is constructed (Fig. b).

In order to develop the forming-limit diagram, the major and minor engineering strains, as measurement from the deformation of the original circles, are obtained as follows. (Note in Fig. b) that the original circle has deformed into an ellipse. The major axis of the ellipse represents the major direction and magnitude of stretching. The major strain is the engineering strain in this direction, and is always positive, because of sheet-metal stretching. The minor axis of the ellipse

represents the magnitude of the stretching or shrinking in the transverse direction of the sheet metal.

Note that the minor strain can be either negative or positive. If, for example, a circle is placed in center of a tensile test specimen and then stretched, the specimen becomes narrower as it is stretch. (Poisson effect) and the minor strain is negative. (This behavior can easily be demonstrated by stretching a rubber band.) On the other hand, if we place a circle on a spherical rubber balloon and inflate it, the minor and major strains are both positive and equal in magnitude.

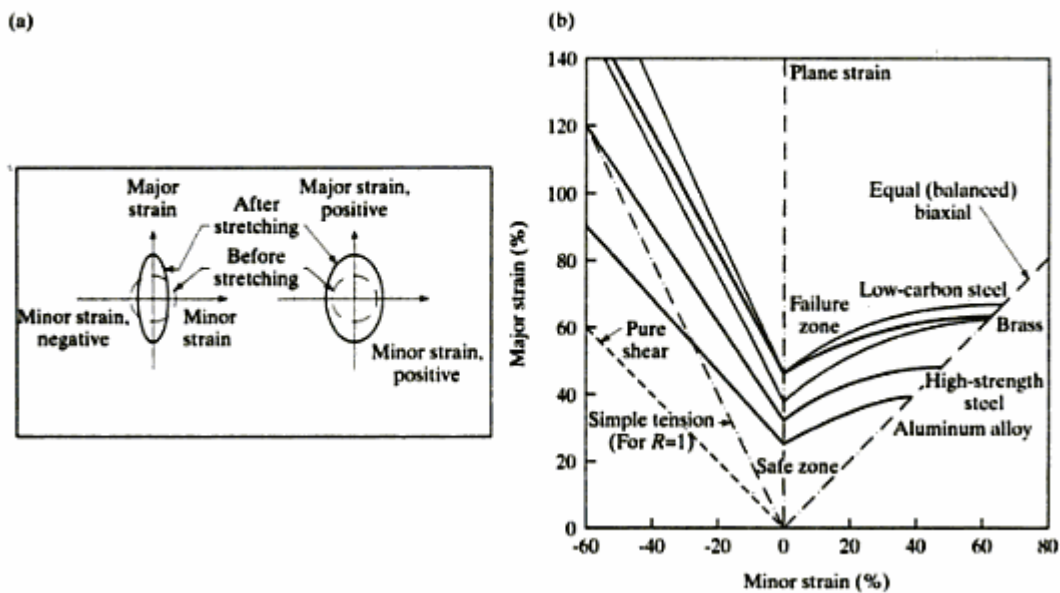


Figure . (a) Strains in deformed circular grid patterns. (b) Forming-limit-diagram (FLD) for various sheet metals. Although the major strain is always positive (stretching), the minor strain may be either positive or negative. In the lower left of the diagram,  $R$  is the normal anisotropy of the sheet,

### 19.Explain briefly micro forming in sheet metal processes

#### MICRO FORMING IN SHEET METAL PROCESSES

Sheet metal components are used extensively in various applications such as vehicles, aircraft, electronics products, medical implants and packaging for consuming goods, typical parts/ components including car panels, aircraft skins, cans for food and drinks, frames for TV/ computer screens/monitors/displays, etc.

Concerning miniature/micro-products, sheet metal parts include electrical connectors and lead frames, micro-meshes for masks and optical devices, micro springs for micro switches, micro-cups for electron guns and micro-packaging, micro laminates for micro-motor and fluidic devices, micro gears for micro mechanical devices, casings/housings for micro-device assembly/packaging, micro knives for surgery etc.,

Traditionally, sheet metals are defined as metal having a thickness of between 0.4 and 6 mm, while micro-sheet forming usually deals with sheet metals of which the thickness is usually below 0.3 mm. Therefore, thin strips or coils shall be the proper words for defining these materials. As with conventional sheet metal forming major material conversion mechanisms in micro sheet forming include shearing/cutting, bending, unbending, stretching, compressing, stress relaxation etc.,

Being the same as for conventional sheet metal forming, the mechanical properties of the materials such as elasticity, plasticity, stress strain relations, strain rate, work hardening, temperature effect, anisotropy, grain size, residual stress, etc., are very important for understanding material deformation/separation mechanisms. The effects of grains sizes, orientations and grain boundary properties are especially significant in micro-sheet forming, considering their effects in the definition of the overall stress/strain relationships, sheared-section qualities, bending curvatures, spring back phenomenon, stress relaxation, etc. For given structures, the effects are more significant, if the relative ratios between the grain sizes and the strip thickness/feature sizes/ part dimensions.

The following sheet forming processes are used in micro forming.

1. Blanking/Punching
2. Bending
3. Deep drawing

#### **APPLICATIONS**

- ❖ Cellular Telephones
- ❖ IC Lead frames
- ❖ Electronics
- ❖ Healthcare
- ❖ Miniature Fasteners
- ❖ Hard Disc Drives
- ❖ National Security & Defense



❖ Automobiles

❖ Sensors

SANCET

**UNIT-V**  
**MANUFACTURE OF PLASTIC COMPONENTS**  
**TWO MARKS**

**Part – A**

**1. Plastic strips are to be converted into 3D objects. Suggest one process and explain. (APRIL/MAY 2010)**

The one of the process can be used for converting plastic strips to 3D objects are vacuum forming process (thermoforming). It is a process in which a heated plastic sheet is changed to a desired shape by causing it to flow against the mould surface by reducing the air pressure between one side of the sheet and the plastic sheet is heater and the mould surface.

**2. Describe briefly the principle of film blowing. (APRIL/MAY 2010).**

Crystalline sharp melting polymers like nylon or PET are very much suited for the film. Production by melt casting techniques. Initially the heated plastic power is extrude by using extrude machines called extruder. In this extruding process, the thin film is produced.

After extrude the thin film, it is stretched by pulling rollers through the child drum in the rolling wheel.

The thin film is cooled in the chilled dream and the rollers are used to pill the film from chilled dream. The rolling wheel is used to make the film roll.

**3. Name two adhesives that are used for adhesive bonding of plastics.(NOV/DEC 2011) (MAY/JUNE 2012)**

Different types of plastic adhesives like epoxy, resins, acrylics, silicones and hot-melt adhesive are regularly used for bonding plastics, metals, glass and a host of other purposes. They are used to address creative, assembly, maintenance and repair concerns in craft, construction, manufacturing and engineering applications.

**4. What are the advantages of transfer moulding? (NOV/DEC 2011)**

1. Before completely filling the metal in the mould cavity, little pressure is maintained inside the mould and this will create full liquid pressure inside the cavity.
2. When the plastic flows through orifice into the cavity, the temperature will increase.
3. Cold press can be used.
4. Viscosity of flow material reduces.

**5. Name two important differences between thermoplastics and thermosetting plastics. (NOV/DEC 2012)**

Sl.NO	Thermoplastics	Thermosetting plastics
1.	It is softened by heating	It cannot be softened by this process.
2.	Structure is made of linear chain molecules.	Structure is made of cross-linked molecules.
3.	It is produced by addition polymerization process	It is produced by condensation polymerization process.
4.	It can be reproduced by heating and cooling	It cannot be reproduced
5.	The temperature increases with increase in plasticity	Plasticity is stable at high temperature

**6. What is film blowing? (NOV/DEC 2012) (MAY/JUNE 2012)(Apl/May-2019)(Nov/Dec-2018)**

Crystalline sharp melting polymers like nylon or PET are very much suited for the film production by melt casting techniques. Initially the heated plastic power is extrude by using extrude machines called extruder. In this extruding process, the thin film is produced.

**7. What is polymerization? (MAY/JUNE 2013)**

A polymer is made up of linking thousand of monomer and thus obtaining large modulus is called polymerization process.

**8. What is calendaring in processing of plastics?(MAY/JUNE 2013)**

A calendar is a device used to process a polymer melt into a sheet or film. It has been in use for over a hundred years and when first developed it was mainly used for processing rubber, but nowadays is commonly used for producing [thermoplastic](#) sheets, coatings and films.

**9. What are the characteristics of thermo plastic? (NOV/DEC 2009)**

The thermoplastic have separate long and large size molecules arranged by side by side, it does not have any cross linking in their molecular structure.

**10. List out the materials for processing plastics.**

a) **Additives:**

- Plasticizer
- Catalyst
- Dyes & pigments
- Initiators
- Modifiers
- Lubricants
- Flame retardants
- Solvents

b) **Fillers:**

- Mica
- Cloth fiber
- Ashes is

**10. List the advantages of cold forming of plastics(NOV/DEC 2009)**

In cold forming process the raw thermo setting material is put into the mould and pressed to shape at a room temperature. It is used to produce the filaments and fibers.

**11. What are the types of plastics? (MAY/JUNE 2009)**

**There are two types of plastics**

- Thermo setting plastics
- Thermo plastics

**12. What are the characteristics of shaping and forming process? (MAY/JUNE 2009)**

- |                       |                                  |
|-----------------------|----------------------------------|
| 1. Injection moulding | 1. High production rates         |
|                       | 2. Good dimensional accuracy     |
| 2. Blow moulding      | 1. Hollow thin walled plates     |
|                       | 2. Low cost of making containers |

**13. What are the types of moulding of thermo plastics? (MAY/JUNE 2008)**

- Injection moulding
- Blow moulding
- Rotational moulding
- Film blowing
- Sheet forming process
- Extrusion process
- Vacuum process

**14. Explain the working principle of**

- A. Injection moulding
- B. Blow moulding

A) The injection moulding is to activate high speed of thermo plastics. The working principle of this moulding is molten thermo plastic is injected into a mould under high pressure.

B) In blow moulding the extrude tube of plastic called parison is placed between the two parts of open moulds. The two valves would moves towards each other so that the mould closes over the tube.

**15. Explain extrusion process. (MAY/JUNE 2008)**

The process consists of feeding the powdered plastic from the hopper into the heated chamber.

**16. Explain thermo forming process.**

It is a process in which a heated plastic sheet is changed in a desired shape by causing it to flow against the mould surface by reducing the air pressure on side of sheet and mould surface.

**17. Explain the working principle of compression moulding. (MAY/JUNE 2006)**

It involves a premeasured density of plastic in the form of particles or briquettes which is placed in a heated mould and compressed at a suitable pressure and temperature.

**18. Explain the working principle of transfer moulding. (MAY/JUNE 2006)**

Transfer moulding is a modification of compression moulding in which the material is first placed in a separate chamber called transfer hot. Then the material is pushed through orifice and into the mould cavity by a action of punch.

**19. What is bonding of thermo plastic? (MAY/JUNE 2007)**

It is done by application of pressure and heat. It consists of layers such as paper, Cellulose glass fiber etc. synthetic resins are used as bonder.

**20. What are the fusion and solvent methods? (NOV/DEC 2006)**

The thermo plastic can be softened and heated as the temperature is increased. They can also be joined by the fusion welding techniques and solvents.

**21. What are the limitations of solvent bonding of plastic? (NOV/DEC 2006)**

- I. Binding energy is low
- II. Mishear and heat affects the strength of bonding
- III. Process is quite complicated

**22. What is calendaring? Why it is used. (MAY/JUNE 2007)**

It is a process of making plastic material into sheet roll.

**23. What is solid state forming? (MAY/JUNE 2005)**

In this the main operation involved are stretching, bending and deep drawing. Food packaging tubes and containers are fabricated by this process.

**24. Mention the advantages of induction welding. (MAY/JUNE 2005)**

- Induction process is fast
- It does not produce an external weld.
- Three dimensional welds are possible.

**25. Difference between thermoplastic and thermo setting plastics. (MAY/JUNE 2004)**

- |   |  |
|---|--|
| 1. It is softened by heating                  | 1.it can be softened by this process.        |
| 2. Structure is made of linear chain moulding | 2.Structure is made of cross linked moulding |
| 3. It is produced by addition                 | 3.it is produced by condensation.            |

**26.What are the different types of compression moulds? (Nov/Dec 2013)**

1. Flash type
2. Landed positive type
3. Positive type
4. Semi positive type

**27.Define pulforming. (Nov/Dec 2013)**

Pulforming can be defined as pultrusion with additional steps to form the length into a semicircular contour and alter the cross section at one or more locations along the length.

**28.write short notes on thermoset plastics(Nov/Dec-2018)**

Thermoset plastics are frequently used for sealed products due to their resistance to deformation and are also among some of the most impact resistant plastics available. Examples of thermoset plastic polymers include epoxies, phenolics, silicones, and polyesters.

## Unit -5

### MANUFACTURING OF PLASTIC COMPONENTS

The word plastic comes from the Greek word Plastikos, meaning “able to be shaped and molded”. Plastics can be broadly classified into two major groups on the basis of their chemical structure i.e. thermoplastics and thermosetting plastics.

#### Thermoplastics

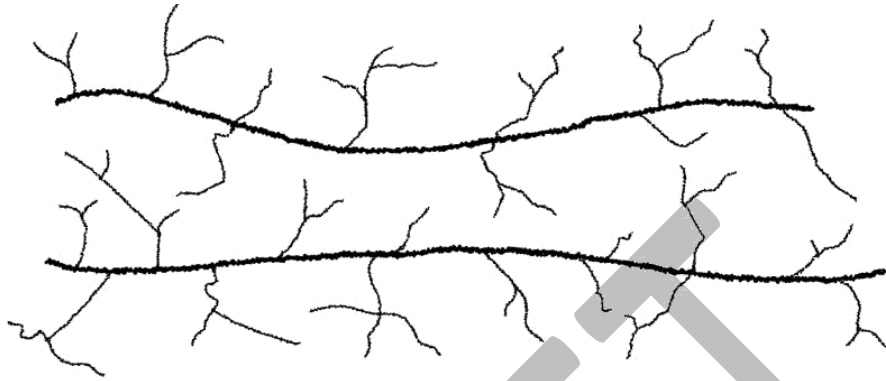
The material that softens when heated above the glass transition temperature or melting temperature and becomes hard after cooling is called thermoplastics. Thermoplastics can be reversibly melted by heating and solidified by cooling in limited number of cycles without affecting the mechanical properties. On increasing the number of recycling of thermoplastics may result in color degradation, thereby affecting their appearance and properties. In the molten state, they are liquids, and in the mushy state they are glassy or partially crystalline. The molecules are joined end-to-end into a series of long chains, each chain being independent of the other. Above the melting temperature, all crystalline structure disappears and the long chain becomes randomly scattered.

The molecular structure of thermoplastic (figure 1) has an influence on the chemical resistance and resistance against environmental effects like UV radiation. The properties may also vary from optical transparency to opaque, depending on the molecular structure. The important properties of the thermoplastics are high strength and toughness, better hardness, chemical resistance, durability, self lubrication, transparency and water proofing.

With the application of heat, thermoplastic softens and it can be molded into desired shapes. Some thermoplastics can be joined with the application of heat and pressure. There are several techniques available for the joining of thermoplastics such as mechanical fastening, fusion bonding, hot gas welding, solvent bonding, ultrasonic welding, induction welding, and dielectric welding.

The different types of thermoplastic are: Acrylonitrile Butadiene Styrene (ABS), Acetals, Acrylics, Cellulosics, Fluorocarbons, Polyamides, Polycarbonates, Polyethylene (PE), Polypropylenes (PP), Polystyrenes, Polyetheretherketone, Polyvinyl Chloride (PVC), Liquid

Crystal Polymers (LCP), Polyphenylene Sulphide (PPS) and Vinyls.



### **Applications**

Thermoplastics can be used to manufacture the dashboards and car trims, toys, phones, handles, electrical products, bearings, gears, rope, hinges and catches, glass frames, cables, hoses, sheet, and windows, etc.

### **Thermosets**

The property of material becoming permanently hard and rigid after cooling when heated above the melting temperature is called thermosets. The solidification process of plastics is known as curing. The transformation from the liquid state to the solid state is irreversible process, further heating of thermosets result only in the chemical decomposition. It means that the thermosets can't be recycled. During curing, the small molecules are chemically linked together to form complex inter-connected network structures (figure 2). This cross-linking prevents the slippage of individual chains. Therefore, the mechanical properties (tensile strength, compressive strength, and hardness) are not temperature dependent, as compared to thermoplastics. Hence, thermosets are generally stronger than the thermoplastics.

The joining of thermosets by thermal processes like ultrasonic welding, laser welding, and gas welding is not possible, but mechanical fastening and adhesive bonding may be used for low strength applications.

The different types of thermosets are Alkyds, Allylics, Amine, Bakelite, Epoxy, Phenolic (PF),



Polyester, Silicone, Polyurethane (PUR), and Vinyl Ester.

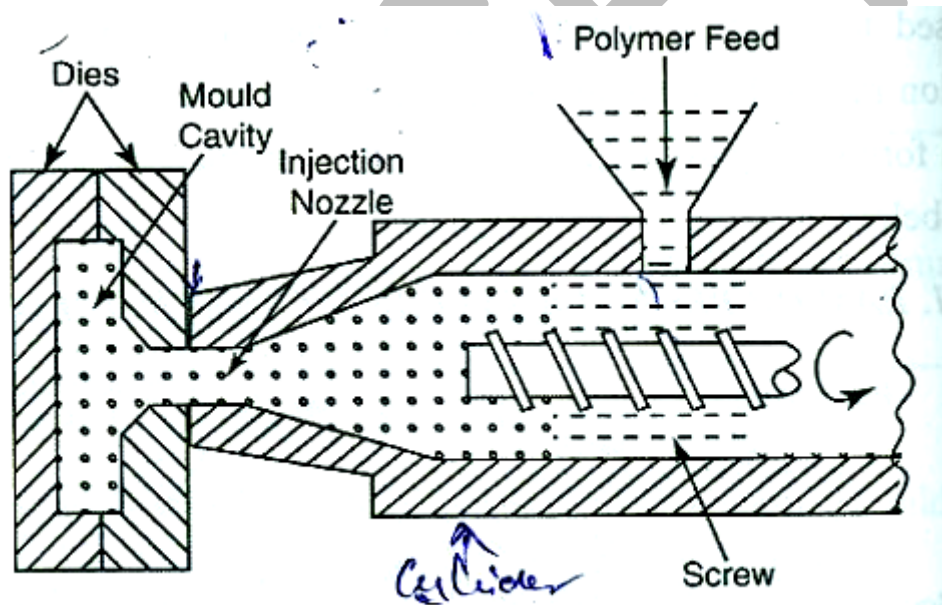
### Applications

Thermosets are commonly used for high temperature applications. Some of the common products are electrical equipments, motor brush holders, printed circuit boards, circuit breakers, encapsulation, kitchen utensils, handles and knobs, and spectacle lenses

### 1. Explain the process of reciprocating screw injecting moulding. (APRIL/MAY 2010) (MAY/JUNE 2012)

In this type also, there are two units to split and eject the finished components such as

1. Injection unit
2. Clamping unit



**Fig. 5.2. Screw type injection moulding**

The injection unit has hopper, screw and heating section. In clamping section it has mould.

In screw type moulding machine, initially the pellets are fed into the hopper the resins are pushed along with the heated reciprocating screw.

The screw is moved forward to force plastic material into the mould.

The screw itself moving backwards and allowing the accumulation of enough material to fill in the mould.

The rotation of screw provides the plasticizing action by shearing and frictional effects.

The jet moulding process is used to final the problems occurred in the injection moulding

process. The reaction moulding is the recent development in injection moulding. In reaction moulding the low viscosity monomers are used in the mould chemical reaction takes place between resins at low temperature and a polymer is created.

In jet moulding, the plastic is preheated about 93°C in the cylinder surrounding the nozzle. The reaction moulding is suitable for productions of polyurethane moulding

**Advantages of injection moulding :**

- High production capacity and less material loss
- Low cost and less finishing operations.
- It is used for making complex threads.
- Accuracy become  $\pm 0.025\text{mm}$
- Wide range of can be moulded.

**Applications:**

1. It is used in making parts complex threads
2. Production of intricate shapes like thin walled parts.
3. Production of typical parts like cups, containers etc.

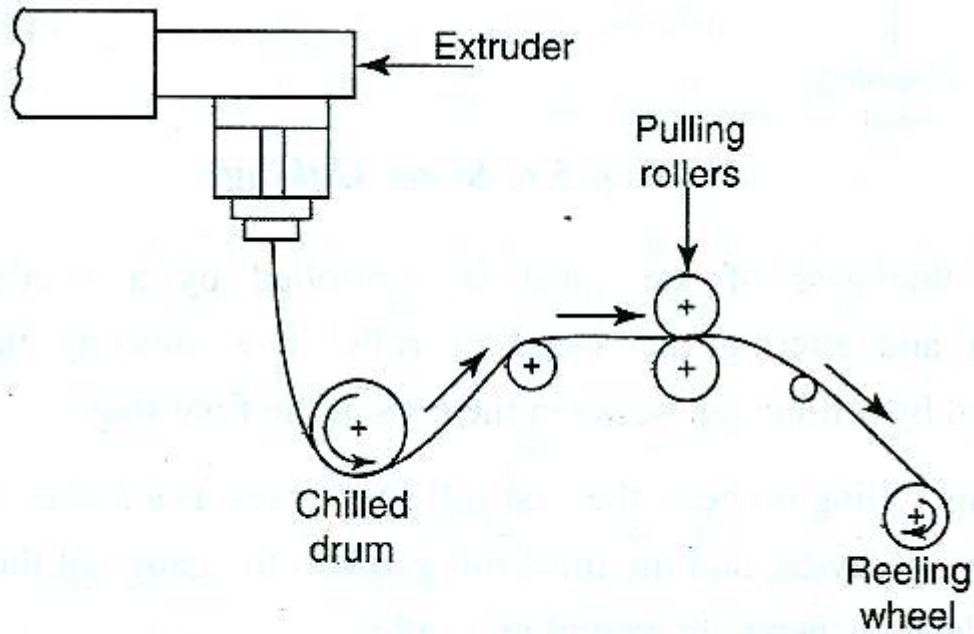
**Limitations:**

1. Equipments of cylinder and die should be non-corrosion
2. Reliable temperature controls are essential.

**2. Enumerate with neat sketch of film blowing.**

**Working principle:**

Crystalline sharp melting polymers like nylon or PET are very much suited for the film. Production by melt casting techniques. Initially the heated plastic power is extrude by using extrude machines called extrudes in this extruding process, and then film is produced.



***Fig. 5.5. Film Blowing***

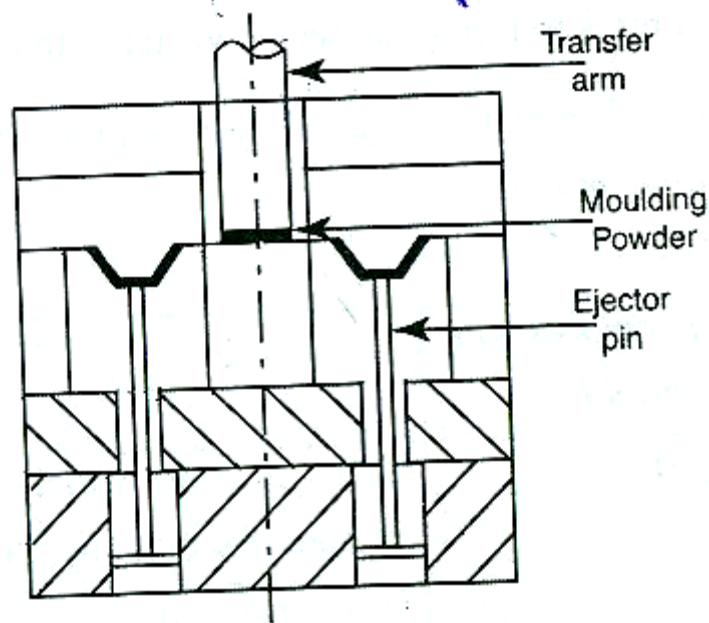
After extrude the thin film, it is stretched by pulling rollers through the child drum in the rolling wheel.

The thin film is cooled in the chilled dream and the rollers are used to pill the film from chilled dream. The rolling wheel is used to make the film roll.

**3. Explain with neat sketch transfer moulding. (APRIL/MAY 2010) (NOV/DEC 2012,2013)**

Transfer moulding is a modification of compression moulding in which the material is first placed in a separate chamber called transfer pot. Then the material is first placed in a separate chamber is pushed in spree through orifice and into the cavity by the action of a punch.

The pressure use in a transfer moulding from 50%to 100% higher than the compression mould and mould is kept at a high temperature. So that the heat transmission is easier when compared with compression moulding



**Fig. 5.10. Transfer moulding**

Transfer moulding cycles are short than compression moulding and moulding is done at high temperature and pressure.

The material to be moulded is often pre-heated by radio-frequency methods. Where it is desired to improve toughness and strength, the reinforcing fillers may be used.

Transfer moulding is generally employed for thick sections and also useful for incorporating metal parts in the moulding. The pre-melted polymer changes flow easily into interior parts with inserts. It is not possible in compression moulding.

**Transfer moulding design:**

The following points are to be considered while designing transfer moulding

1. Flow of materials should be easy
2. Ejecting of moulding should be easier.
3. Heating of all the parts should be uniform.

**Advantages:**

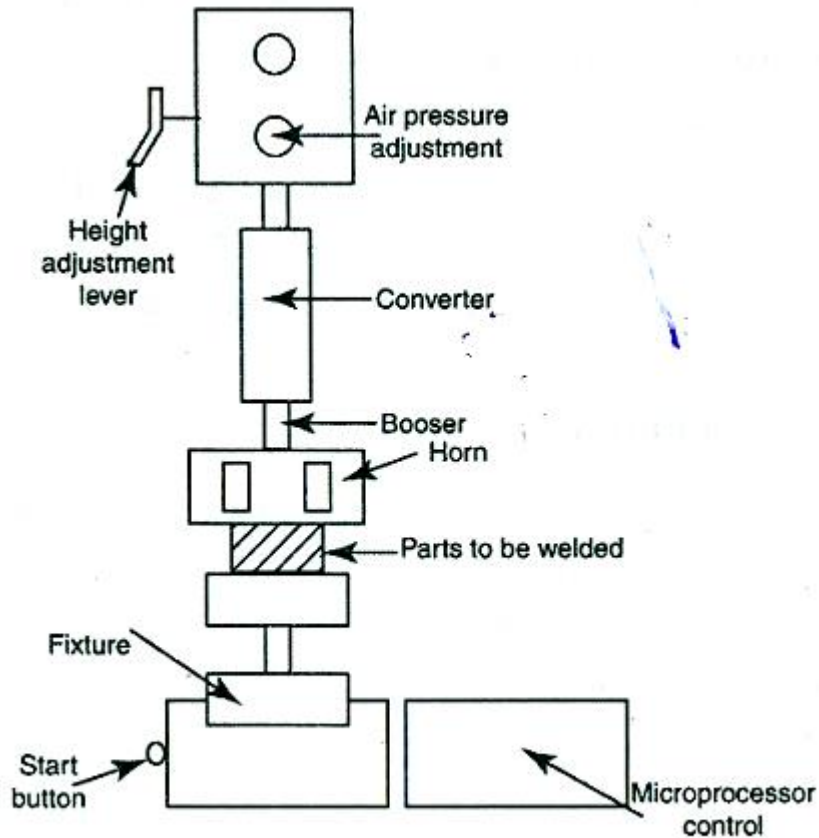
1. Before completely filling the metal in the mould cavity, little pressure is maintained inside the mould and this will create full liquid pressure inside the cavity.
2. When the plastic flows through orifice into the cavity, the temperature will increase.
3. Cold press can be used.
4. Viscosity of flow material reduces.

**Applications:**

1. It is used for less mass production
2. Short runs of mould metal during the moulding

3. Shape of mould can be readjusted

4. Explain the process of ultrasonic welding of plastics. (APRIL/MAY 2009)



**Fig. 5.14. Ultrasonic welding**

Ultrasonic welding is the conversion of high frequency electrical energy into high frequency mechanical energy. This mechanical energy is a critical motion in excess of 15000 cycle's seconds.

This vibratory motion is transferred to a thermoplastic under pressure. Frictional heat is generated at the interface or joins of two pieces of thermo plastic or with a metal and thermoplastic or with a metal and thermoplastic.

It is done through an ultrasonic welder. The welding power supply converter standard 60Hz alternating current to 15000Hz, 20000Hz or 40000Hz.

This alternating current enters the converter where it is converted to vertical mechanical motion equal to the AC-15,000 , 2000 ,40000 vertical cycles 1 sec and this vertical motion comes out at the other end of converter . Then it is passed through a booster which can increase the amplified of the vibrating motion.

**Advantages:**

1. It is used for the assembly of thermo plastic material.
2. Alternate to using solvents or heat as bonding method
3. It is used in automotive, medical and toy production.

#### **5. Explain different types of plastic with its application.**

All plastics are broadly classified into two main types.

- Thermosetting plastics
- Thermo plastics

#### **Thermosetting plastics**

The plastics which are hardened by heat effecting a non reversible chemical change are called thermo setting.

#### **1. Phenol formaldehyde**

It is also named as Bakelite. It is made by the reaction of phenol with formaldehyde. It is generally produced in dark color and it has high strength, stability and rigidity. It can be easily cast or laminated

**Uses:**

Plugs, knobs, pulleys, Bohlen caps, tooling and forming dies.

#### **2. Polyester resin**

It has low moisture, good electrical resistance and variety of color. It is used in paper mat, Tv parts car bodies. The main drawback of the polyester is high cost .

#### **3. Melamines:**

It has excellent electrical and heat resistance. It has good stability and low moisture absorption. The melamines are available under various names of melmac, catlin, melantine and plaskon. It is widely used for moulded parts.

**Uses:**

Telephones sets , circuit breaker, switch panels, lighting fixtures.

#### **4. Phenol furfural:**

It has good flow ability at low moulding temperature and sets quickly at correct temperature. The phenol furfural has good resistance to moisture and electricity.

**Eg:-**

Brake linings, electrical parts, and instrument cabinets

#### **5. Epoxy resins:**

The most popular variety of epoxy resin is araldite. It has good chemical and electrical resistance It is mostly available in the form of liquid. They also have good resistance to wear and impact. But they are quite expensive.

**Uses:**

Tools and dies, jigs and fixtures housings for electrical parts, enamels.

## **6. Silicones:**

Silicones have high resistance to high temperature up to 260°C and poses excellent dielectric strength at high temperature. In liquid form, they are used as water repellants. They can be compressed and reinforced.

### **Uses:**

It is used in coatings, laminates, foam products, induction heating apparatus

## **7. Urea formaldehyde:**

It is obtained by the condensation of urea and aqueous formaldehyde. It cannot be cast. But it can without temperature upto 77°C only. It is widely used as an adhesive and binding material.

### **Uses:**

It is used in toilet seats, table ware, buttons, clock cases, electric switches and plugs

## **1. Thermoplastics:**

The thermoplastics have separate long and larger size molecules arranged side by side. It does not have any cross linking in their molecular structure.

I. Cellulose derivatives

II. Cellulose nitrate

It is obtained by treating the Cellulose with a mixture of nitric acid

### **Uses:**

Spectacles frames toilet articles pen bodies

## **2. Cellulose acetate:**

It is obtained by treating the Cellulose with acetic acid. It can be injected and compressed in the mould for obtaining better stability.

### **Uses:**

Photographic films buttons radio panel

## **3. Ethyl Cellulose:**

The ethyl Cellulose is the lightest of all Cellulose derivatives It has good electrical properties

### **Uses:**

Jigs fixture forming dies hose nozzle.

## **4. Cellulose acetate- butyrate:**

It is obtained by treating Cellulose with acetic acid and boric acid

### **Uses:**

Radio cabinet's pipes and tubing

## **5. Cellophane:**

It is a amiable in extrude form it has attractive appearance and good resistance to moisture

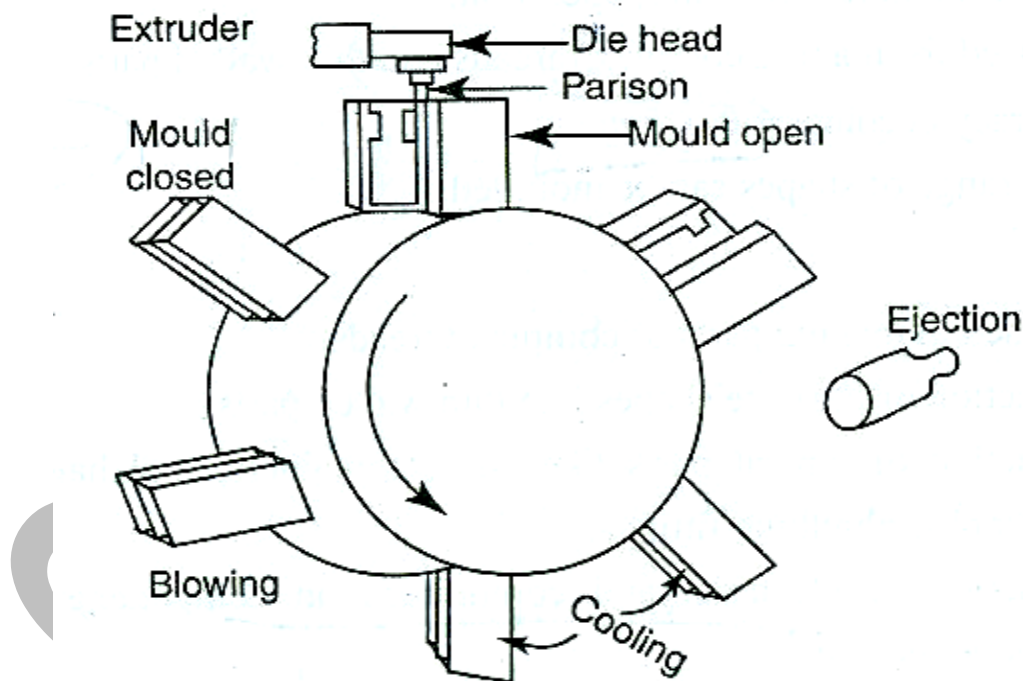
### **Uses:**

Fountain-pens, telephones, flash light cases

**6. Explain blow moulding process.(NOV/DEC 2011,2013) (MAY/JUNE 2012, 2013)**

In this process, a hot extrude tube of plastic called parison is placed between the two parts of open moulds. The two valves of the mould move towards each other so that the mould closes over the tube.

The bottom end of parison is seated. The compressed air is used to blow the molten plastic in to the mould and tube gets pinched off and also welded at bottom by the closing moulds. The air pressure is about 0.7 to 10kg/cm<sup>2</sup>. This air pressure will force the tube against the walls of mould. Finally the component is cooled and mould opens to release components. The blow moulding method ranges from simple manual operation to complicated automatic ones. The various types of blow moulding process are



**Fig. 5.3. Blow Moulding**

1. Injection blow moulding
2. Extrusion blow moulding
3. Multi layer blow moulding

In multi layer blow moulding multi layer structure are used. Typical example for multi layer blow moulding is plastic for good

**Applications:**

1. It is used in making plastic bottles and toys.
2. The hollow containers are produced by this process.



3. The multi layer blow moulding used in cosmetics and pharmaceutical industries.

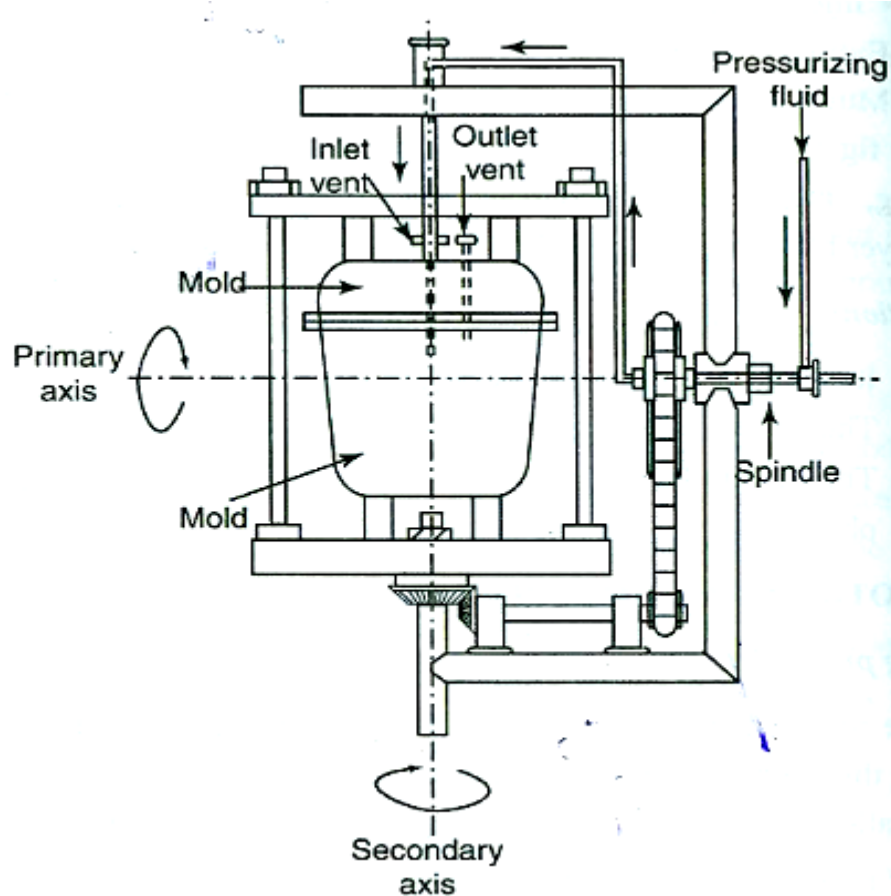
**7. Describe with neat sketches various steps involved in rotational moulding. State its application. (APRIL/MAY 2010) (MAY/JUNE 2012) (MAY/JUNE 2013)**

**Working principle:**

The rotational moulding process is used to make thin walled hollow parts. In this method, a measured quantity of polymer powder is placed in a thin-walled metal mould. The mould is closed and it is rotated about two mutually perpendicular axes as it is heated.

This rotation will cause the powder to sinter against the mould walls. After heating and sintering, the mould is cooled while it is still rotating. The cooling of mould is done by using water and air. Then the rotation is stopped when mould component is removed.

In this rotational moulding, thin walled metal mould is made of two pieces and is rotated in perpendicular axis. A measured quantity of powdered plastic material is placed inside the mould. Then the mould is heated and rotated. This action tumbles the powder against the mould where heating fuses the powder without melting it. Most thermoplastics and some thermosets can be formed into large hollow parts by rotational moulding. In some parts, chemical agents are added to the powder and cross-linking after the parts is formed in the mould by continuous heating.



**Fig. 5.4. Rotational Moulding**

Rotational moulding can also produce parts with complex hollow shapes with wall thickness of 0.4 mm minimum. Large size parts as 1.8m x 1.8m x3.6m can also be formed by this process. The surface finish of the mould is same as that of surface finish of walls. The temperature – time relationship during the oven cycle is very important.

#### **Applications**

1. It is used to produce toys in P.V.C.
2. It is used to make large containers of polyethylene.
3. It is used to make petrol tanks for motorcars from polyethylene and nylon.
4. Metallic or plastic inserts are moulded by this process.
5. The buckets, housings, boat hulls and trashcans are made by this process.
6. It is used to produce tanks of various sizes, boat hulls and footballs.

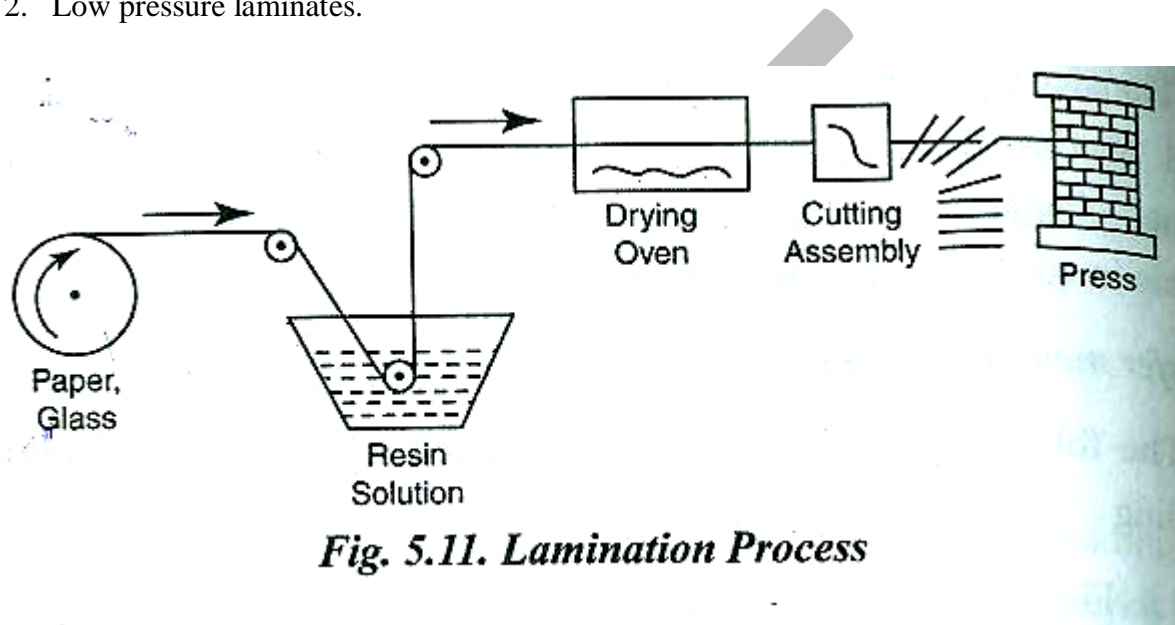
**8.What are the methods of bonding thermoplastics? Explain any one method.**  
(APRIL/MAY 2010) (MAY/JUNE 2013)

It is done by the application of pressure and heat. It consists of layers, such as paper,

cellulose, glass fiber etc. synthetic resins are used as a binder. The thermoplastics are bonded by the process of lamination.

The lamination process is classified into two categories:

1. High pressure laminates
2. Low pressure laminates.



**Fig. 5.11. Lamination Process**

In high-pressure laminates, the pressure applied is **upto 7 Mpa** and temperature of about **150<sup>0</sup>C**.

In low-pressure laminates, the pressure requirement is very less when compared with high pressure laminates. Material like asbestos, cotton, fibres are fabricated by this process. The low-pressure laminates are also called "**Reinforced plastics**".

The figure shows the lamination process in which the paper and glass are immersed in the resin solution using the rollers and then resin mixed plastics are dried in the drying oven. The dried plastics are cut in the cutting section. After cutting, it will be pressed by the press.

The stages involved in laminations are

1. Saturation of the base with the resin solution.
2. Wet drying
3. Size cutting
4. Pressing

The laminated plastics are used in electrical and electronic components and also for mechanical devices. In furniture industry, the decorative laminations are used.

The reinforced plastics have the characteristics of

1. Elastic stability
2. Less weight

### **Applications**

1. Making thin sheets.
2. Making aircraft panels.
3. Making horns.
4. Making storages bins.

**9. Briefly explain the following plastic processing methods, with the help of neat sketches (NOV/DEC 2011) (MAY/JUNE 2013)**

- i. Fusion bonding**
- ii. Vibration welding**
- iii. Solvent bonding**
- iv. Induction welding**

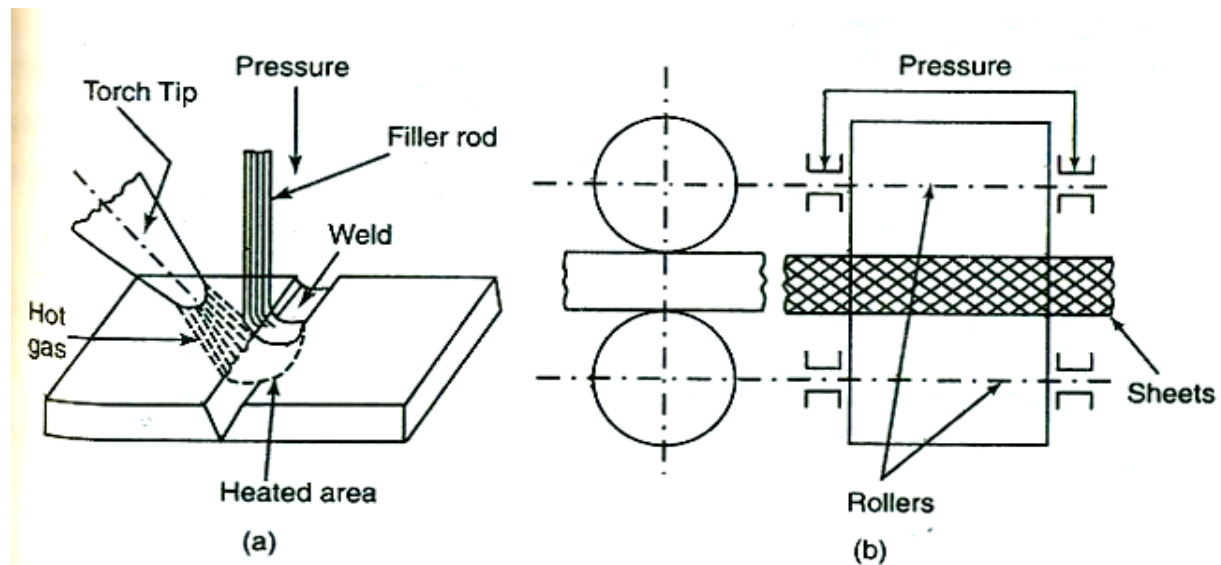
#### **i) Fusion bonding**

The thermoplastics can be softened and melted as the temperature is increased. They can also be joined by the fusion welding techniques and solvents.

The heat source in fusion welding of thermoplastics is usually hot air or other gases. Actually, the heat melts the joint and the joint takes place by the application of pressure.

The common welding pressure for plastics are given below.

- 1. Hot gas welding.**



**Fig. 5.12. Hot Gas Welding**

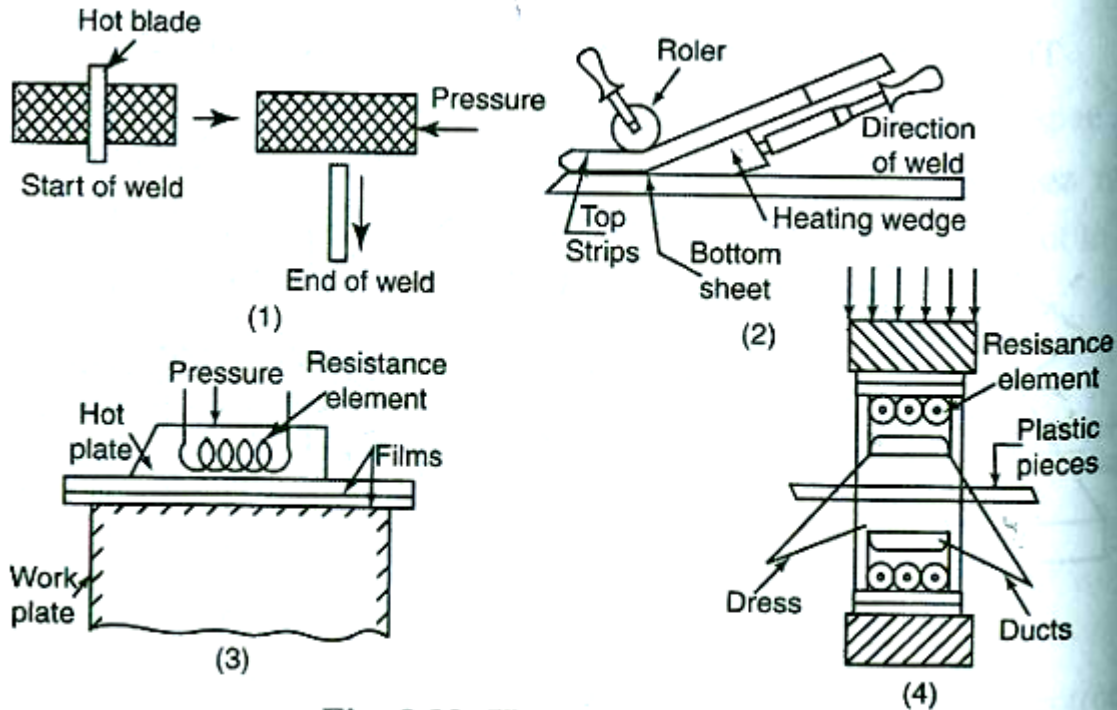
In this process, the hot gas from a torch is used to join the plastics. The gas used in this type of gas welding may be air, nitrogen, fuel gas, acetylene or hydrogen.

The working principle of hot gas welding is, the hot gas from torch heats the edges and the filler rod to viscous fluid state. If the filler rod is forced down by hand, it will weld the softened edges and form a weld. It is just like a gas welding.

The other method without filler rod to join the process is also shown in figure. In this, the edges are uniformly heated by hot gas and the hot gas jet followed by cold rollers is used to complete the weld by the application of pressure.

## **2.Hot tool welding**

In hot tool welding process, a hot tool transfers the heat to the plastic workpiece by direct contact.



**Fig. 5.13. Hot Tool Welding**

The four different hot tool welding processes which are used in join the plastics are shown in figure.

In Figure (1), the hot blade is placed between the surfaces to be joined. After softening the surface, the blade is withdrawn from it. Then the joint is completed by applying pressure.

In figure (2), the heating wedge is placed between the surfaces to be joined and is moved along the line of welding as the edges are softened. The pressure for welding is given by the rollers to complete the joint.

In figure (3), a hot plate heated by a resistance elements is moved over the films to be joined and the pressure is applied to complete the joint.

In figure (4), the heat is transferred to the area of welding by the hot platen of a welding press. The edges of the plastic are scared and champed in press having platens heated by resistance element. They are allowed to stay under pressure after the work pieces are raised to the welding temperature.

### iii. Solvent bonding

In solvent welding or bonding, a solvent is applied which can temporarily dissolve the polymer at room temperature. When it occurs, the polymer chains will move in the liquid and

can entangle with other similarly dissolved chains in the other component.

When giving sufficient time, the solvent will permeate through the polymer and out into the environments so that the chains lose their mobility.

The PVC pipe may be joined to a fitting from the same polymer using solvent welding.

First, the surface of the parts are cleaned and the solvent cement is applied. The cement contains the solvent for the polymer together with a small quantity of the polymer to give the cement the consistency of syrup, making application easier. Then the parts are made to contact each other and remained so for in the position for a predetermined period.

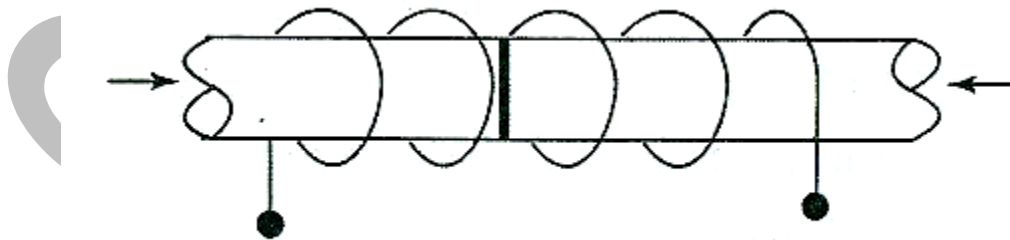
This process will allow the solvent to dissolve the surface of the component to produce the required polymer chain entanglement and then to permeate away through the materials.

### **Application**

1. It is used in manufacturing pipe systems and toys.

### **iv) Induction welding**

In this induction welding, a high frequency generator produces an oscillating magnetic field within a coil that is in close with the work piece.



**Fig. 5.15. Induction welding**

The weld material is affected by this magnetic field and it generates the heat within itself. Then it melts and flow into the joint cavity conducting heat to the host material.

So, the molten metal forming a high integrity joints when fused together. The weld material is directly within the joint. Then the host material is not thermally stressed.

### **Advantages**

1. Induction process is fast.

2. It does not produce an external weld.
3. Three-dimensional welds are also possible.

**10. Describe the following plastic processing methods, with the help of neat sketches: (NOV/DEC 2011)**

**(i) Blow moulding. (Refer Q.NO.6)**

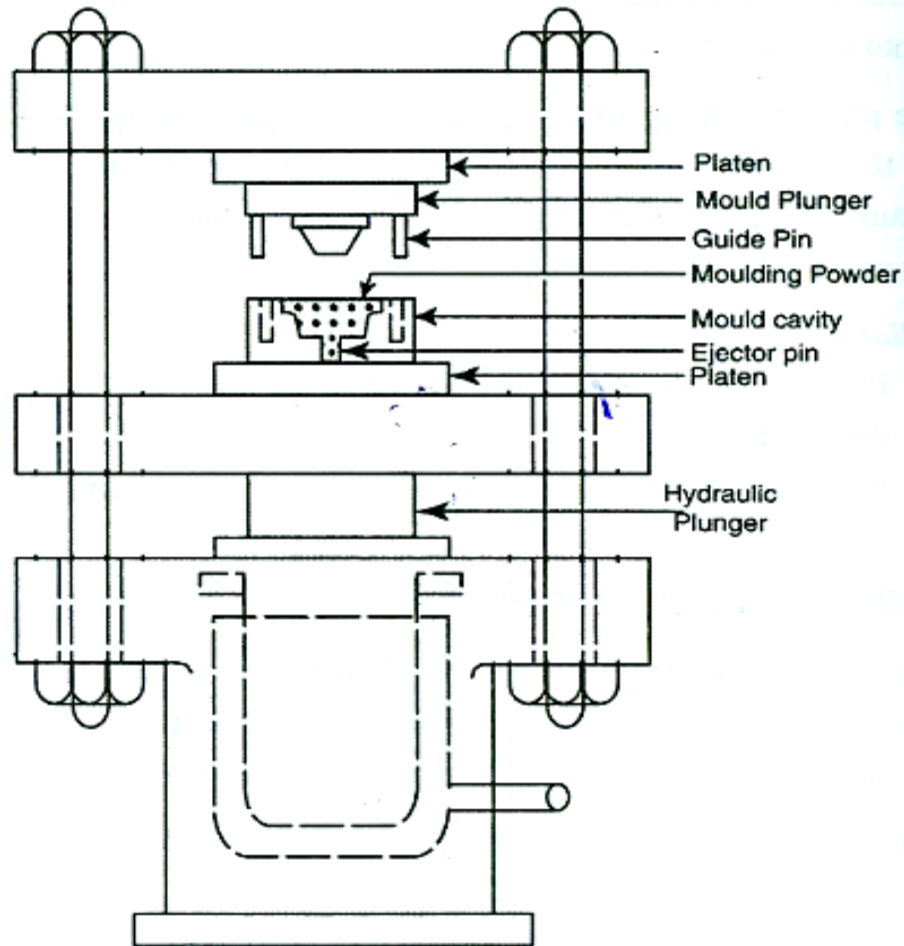
**(ii) Compression moulding (NOV/DEC 2012, 2013)**

The compression moulding is widely used for thermosetting polymers and it is also used to thermoplastic polymers. It involves a pre-measured quantity of plastic in the form of particles or briquettes which is placed in a heated mould and compressed at suitable pressure and temperature.

The charge is placed in the heated mould cavity and mould is closed. The desired compression is given by compression press thereby resulting immediate contact of the polymer charge with all parts of the mould.

Both the pressure and heat ensure the flow of resin, filling of all the parts and corners of the cavity. For thermosetting systems, the pressure is maintained till the linking is obtained an optimum level. Finally, the mould is opened and ejected from the cavity.





**Fig. 5.9. Compression moulding**

The mould is cooled below the transition temperature before the mould is opened while making thermoplastics. This is the cyclic process. The interval covering the mould cycle is known as cycle time.

A slight excess material is placed in the mould and squeezed out between the mating surfaces of the mould. The use of perfumes against moulding powder gives low compression ratio and breathing is helpful in eliminating voids and improves the quality of mould.

The moulding temperature of thermosetting materials ranges from 150<sup>0</sup> C to 180<sup>0</sup> C. The time required to harden the mould pieces ranges from 1 to 15 minutes. The compression moulding has four basic types.

1. Flash type(Some of the material is allowed to escape while moving die)
2. Landed positive type
3. Positive type

#### 4. Semi positive type

The compression moulding is the equivalent of closed – die forging. Hydraulic presses are usually employed to provide the pressure which may range from 20 to 30 Mpa or even higher upto 80 Mpa. The main objective of compression moulding is to bring the plastic virtually to a molten state.

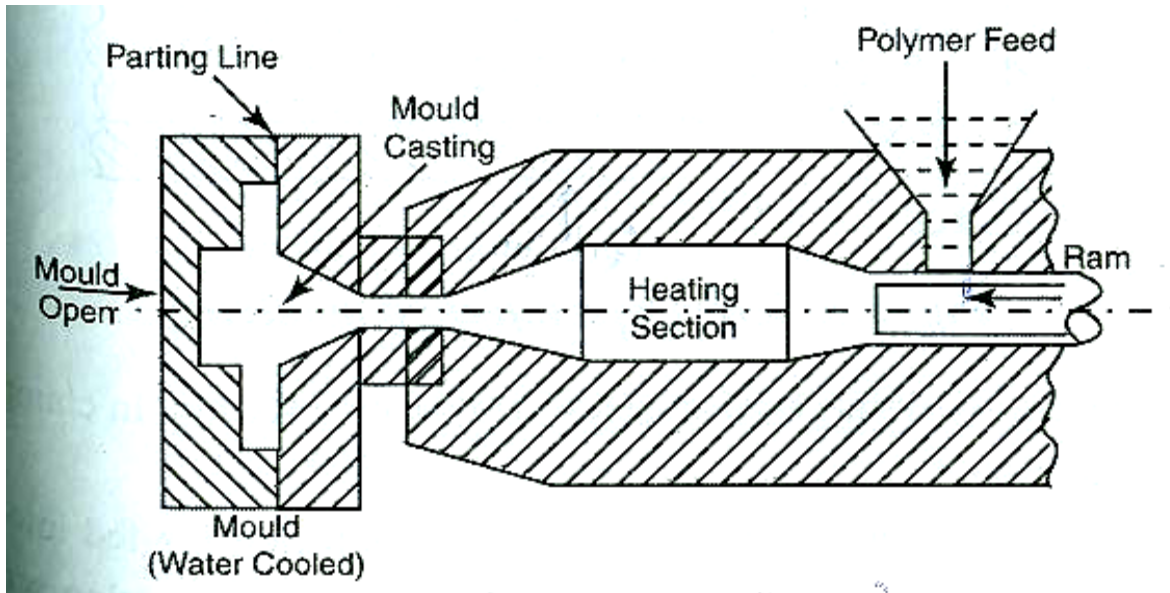
When the plastic is completely trepped between the male and female die, it is called as **positive mould**.

Sl. No	Type of compression mould	uses
1.	Flash type	This is the widely used method for making plastics.
2.	Landed positive type	It is used for high impact material
3.	Positive type	It is used for high impact material and deep draw
4.	Semi positive type	For deep drawing this method is used.

#### Application

1. It is used to make dishes, handles, container taps, and fittings.
2. Electrical and electronic components, washing machine agitators and housings are made by this process.

**11. Describe briefly the plunger type injection moulding process for producing plastic components. (NOV/DEC 2012) (MAY /JUNE 2010)**



The ram and plunger type injection moulding has two units.

1. Injection unit
2. Clamping units

So it may be split in order to eject the finished components.

Initially, the polymer is filled in a hopper. Then it goes to the heating section where the polymer is melted and the pressure is increased. The heated material is injected by the ram under pressure. So, the heated material is forced to fill in mould cavity through the nozzle to get the required shape of the plastic. Here, the mould is water-cooled type.

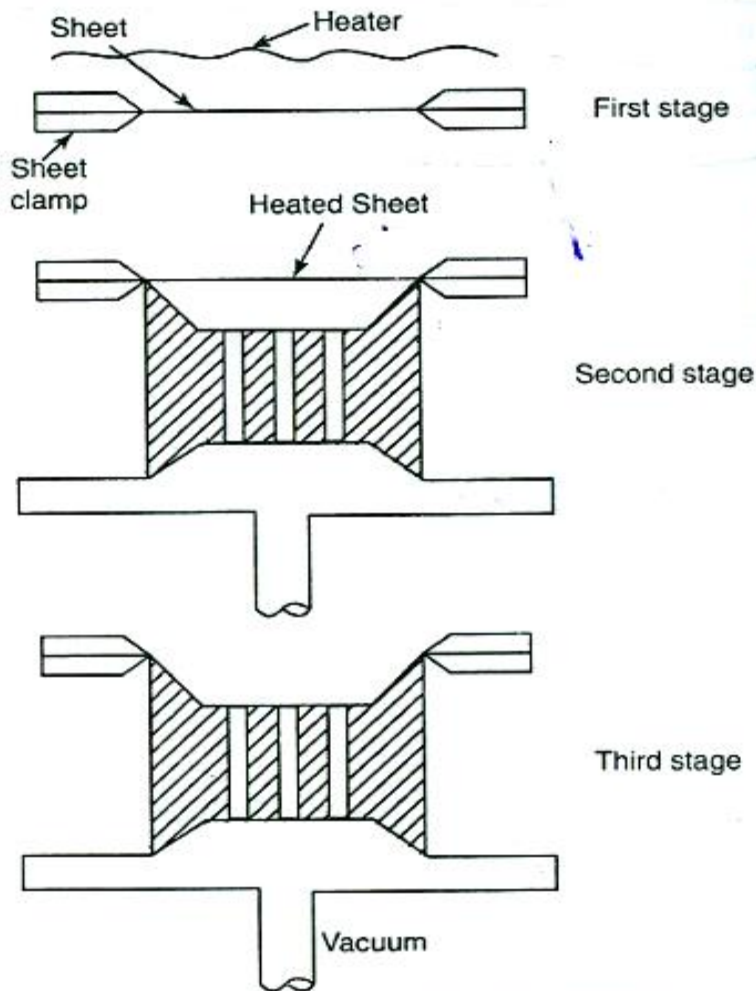
**12.Explain, with neat diagram, the thermoforming process. State its advantages over other process. (NOV/DEC 2012)**

**Vacuum forming process (THERMO FORMING)**

**Working principle:**

It is a process in which a heated plastic sheet is changed to a desired shape by causing it to flow against the mould surface by reducing the air pressure between one side of the sheet and mould surface.

The figure shows the vacuum forming process in which the plastic sheet is heated in a heater and the sheet is fixed in a clamp in the first stages.



**Fig. 5.8. Thermo forming stages**

In the second stages, the heated sheet is placed on the die where the air between the sheet and mould is removed.

In the third stages, increasing intensity draws the sheet against the surface of the mould where it cools and solidifies.

The vacuum forming process is also called “thermoforming”. If large surface area moulds are used, it will be very difficult to stretch the plastic into the mould. In this case, the mechanical assist is given to stretch the plastic into the mould.

The main advantage of this process is low cost and quick process of making the sheet. In this, the air pressure acts as a cushion and temperature of the air delays the sheet cooling. A wide variety of plastic products are made by this thermoforming.

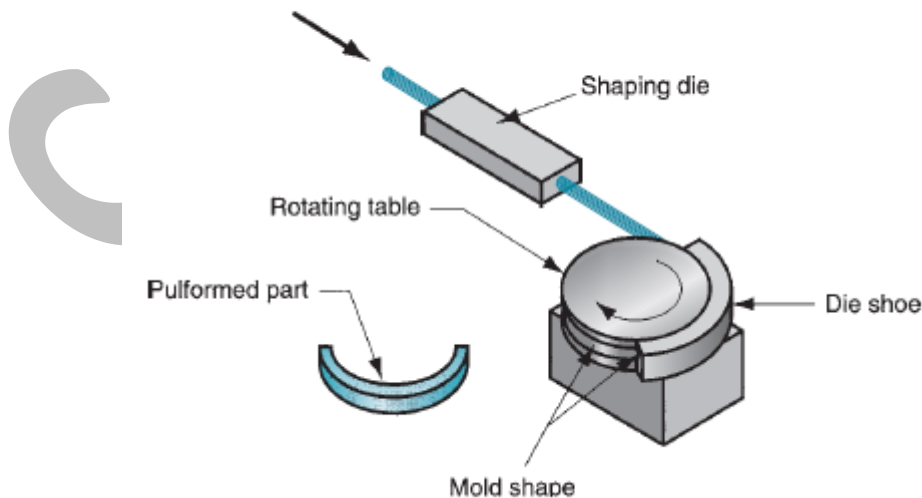
## Applications

1. It is very much useful for making trays, drink cups, refrigeration door lines.
2. It is used for making panels for shower stalls and advertising signs.

### 13.Explain with neat sketch pulforming process.(Nov/Dec 2013)

The pultrusion process is limited to straight sections of constant cross section. There is also a need for long parts with continuous fiber reinforcement that are curved rather than straight and whose cross sections may vary throughout the length. The pulforming process is suited to these less-regular shapes. Pulforming can be defined as pultrusion with additional steps to form the length into a semicircular contour and alter the cross section at one or more locations along the length. A sketch of the equipment is illustrated in Figure . After exiting the shaping die, the continuous workpiece is fed into a rotating table with negative molds positioned around its periphery. The work is forced into the mold cavities by a die shoe, which squeezes the cross section at various locations and forms the curvature in the length. The diameter of the table determines the radius of the part. As the work leaves the die table, it is cut to length to provide discrete parts. Resins and fibers similar to those for pultrusion are used in pulforming. An important application of the process is production of automobile leaf springs.

#### Section 15.6/Other PMC Shaping Processes 341



**Pulforming process**  
(not shown in the sketch is the cut-off  
of the pulformed part).

SAMPLE